

Chemical, Petroleum and Environmental Engineering

The Use of Copper and Aluminum Electrodes for Energy Production in a Microbial Fuel Cell

Muayad F. Hamad
Lecturer
Dept. of Chemical Engineering
College of Engineering
Al-Nahrain University
E-mail: novel1969@yahoo.com

Israa S. M. Ali
Lecturer
Dept. of Chemical Engineering
College of Engineering
Al-Nahrain University
E-mail: israa77shakir@yahoo.com

Dr.Hussein A. Alabdly
Lecturer
Dept. of Chemical Engineering
College of Engineering
Al-Nahrain University
E-mail: husalabdly@yahoo.com

Huda D. Abdul Kader
Lecturer
Dept. of Chemical Engineering
College of Engineering
Al-Nahrain University
E-mail: huda_diaa@yahoo.com

Dr.Basim O. Hasan*
Professor
Dept. of Chemical Engineering
College of Engineering
Al-Nahrain University
E-mail: basimohasan13@gmail.com

ABSTRACT

Microbial fuel cell is a device that uses the microorganism metabolism for the production of electricity under specific operating conditions. Double chamber microbial fuel cell was tested for the use of two cheap electrode materials copper and aluminum for the production of electricity under different operating conditions. The investigated conditions were concentration of microorganism (yeast) (0.5- 2 g/l), solutions temperature (33-45 °C) and concentration of glucose as a substrate (1.5- 6 g/l). The results demonstrated that copper electrode exhibit good performance while the performance of aluminum is poor. The electricity is generated with and without the addition of substrate. Addition of glucose substrate up to 3 g/l increased the produced current but with further increase of the amount of substrate, the current generated decreases. The optimum temperature for electricity production was found to be 36 °C.

Keywords: microbial fuel cell; copper electrode; aluminum; yeast; glucose substrate

استخدام قطبي النحاس والالمنيوم لانتاج الطاقة الكهربائية في خلية الوقود البكتيري

د. باسم عبيد حسن استاذ قسم الهندسة الكيميائية جامعة النهرين-كلية الهندسة	هدى ضياء عبد القادر مدرس قسم الهندسة الكيميائية جامعة النهرين -كلية الهندسة	د. حسين علي حميد مدرس قسم الهندسة الكيميائية جامعة النهرين-كلية الهندسة	اسراء شاكر محمد مدرس قسم الهندسة الكيميائية جامعة النهرين-كلية الهندسة	مؤيد فاضل حمد مدرس قسم الهندسة الكيميائية جامعة النهرين-كلية الهندسة
---	--	--	---	---

الخلاصة

خلية الوقود البكتيرية هو جهاز يستخدم في عملية التمثيل الغذائي للكائنات الحية المجهرية لإنتاج التيار الكهربائي في ظروف محددة. تم دراسة خلية الوقود الميكروبية والمتألفة من حوضين ولاستخدام معدنين رخيصين هما الالمنيوم والنحاس كأقطاب لإنتاج التيار الكهربائي وفي ظروف تشغيلية مختلفة حيث تم دراسة تأثير تركيز الكائنات المجهرية (خميرة الخبز) (0.5 - 6

*Corresponding author

Peer review under the responsibility of University of Baghdad.

<https://doi.org/10.31026/j.eng.2020.06.06>

2520-3339 © 2019 University of Baghdad. Production and hosting by Journal of Engineering.

This is an open access article under the CC BY4 license <http://creativecommons.org/licenses/by/4.0/>.

Article received: 18/10/2019

Article accepted: 5/ 2/ 2020

Article published:1/6 /2020



غم/لتر) ودرجة حرارة المحلول (33-45 م) وكذلك تم دراسة اضافة السكر كمادة مساعدة على التخمر البكتيري وبتراكيز (1.5-6 غم/لتر). اظهرت النتائج ان قطب النحاس يظهر اداء جيد في توليد التيار الكهربائي بينما يكون اداء الالمنيوم ضعيف. ان توليد التيار الكهربائي تم باضافة السكر وكذلك بدون اضافة للسكر وتبين ان اضافة السكر الى حد 3 غم/لتر يزيد من انتاجية التيار الكهربائي ولكن زيادة كمية السكر المضاف الى تركيز اعلى من هذا التركيز يقلل كمية التيار المتولد. ان افضل ظروف لدرجة الحرارة في انتاج التيار الكهربائي وجدت عند 36 م.

الكلمات الرئيسية: خلية الوقود الميكروبية، قطب النحاس، الالمنيوم، الخميرة، التخمر البكتيري.

1. INTRODUCTION

Microbial fuel cells (MFCs) are a type of fuel cells that are considered a new source of clean energy. This technology changes the energy saved in chemical bonds in organic compounds to electrical energy by microorganisms (**Rahimnejad, et al., 2011; Ismail and Jaeel, 2013**). The microbial fuel cells are classified into two kinds depending on the way of the current transfer from microorganism (MO) to the electrodes. The first kind is mediator cells in which the mediators are added into the solution to enhance the electron transfer and the second which is mediatorless, where no mediator is added (**OH, et al., 2004**). It is a new bio-electrochemical device which generates electricity from biodegradable materials (**Li, et al., 2014, Khudzari et al., 2019**). Common substrates that were used in previous investigations for feeding the MO in the cell are pure hydrocarbons such as glucose, acetate, or lactate (**Guerrero, et al., 2014**). Several parameters affect the performance of MFC such as, electrode type, temperature, pH, solution resistance, inoculums and substrate (**Ghoreyshi, et al., 2011; Jiang et al. 2020**). The performance of MFCs is greatly influenced by the material of electrodes used and their properties such as the geometry, surface area, MO and substrate adhesion, electrical conductivity, and electrochemical efficiency (**Mustakeem, 2015, Baudler et al., 2015, Liu et al., 2020**). There are many electrode materials used to scale up the energy production using different MO types and concentrations. The principle of MFCs depends on the fact that the generation of current is dependent on the nature of MO as they transfer the electrons from an electron donor to an electron acceptor of relatively high electrochemical potential (**Ali, et al., 2018**). Some authors proposed that the microorganism is capable of transferring the electrons directly to the electrode by direct electron transfer mechanism (**Torres, et al., 2010**). Other pathways include the use of a conductive polymeric matrix and conductive nanowires for direct contact to the anode (**Marcus, et al., 2007, Laspidou and Rittmann, 2004**). When MO degrade the substrate in aerobic conditions, the CO₂ and water form, while when in anaerobic conditions (O₂ absence) they produce CO₂, electrons, and protons (**Moawad, 2013**):

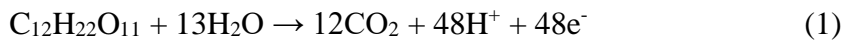

Mediatorless MFCs are found not to require mediators to increase electron transfer rate to MFC electrodes. These mediatorless cells utilize the conversion of the chemical energy into electricity using the active microbial consortium as biocatalysts. The MO oxidizes the organic substances and the produced electrons transfer to the electrode (**Jong, et al., 2006**). It has been reported by previous works that different MO can produce electricity in the absence of an exogenous mediator from chemicals such as glucose, format, lactate, acetate, pyruvate, benzoate, and hydrogen (**OH, et al., 2004; Ismail and Mohammed, 2017**).

Temperature is an important parameter that affects the performance of microbial fuel cell. (**Jadhav and Ghangrekar, 2009**) found that the performance of a double chamber MFC was better when working at lower temperature range. In that work the authors found that for temperature range from 20-35 °C the removal of substrate is high but the current produced is low. However, for low temperature range 8- 22 C the removal of substrate is low but the produced current is high. (**Tang et.al., 2012**). Reported that the electrode materials play important role in catalyzing the biochemical reactions and reducing the resistance for electrons transfer. In addition,



most improvement of the MFC efficiency can be attained by increasing the reactive surface area (Sanchez, 2013). The performance and cost of electrodes are the most important aspects in the design of microbial fuel cell reactors (Wei, et.al. 2011). Therefore, it is of practical significance to seek efficient and cheap electrode material for increasing the performance of MFC.

The aim of this work is to investigate the suitability of using copper and aluminum as a relatively cheap electrode materials in a microbial fuel cell for the production of bioelectricity for ranges of microorganism concentrations, solution temperature, and substrate concentration.

2. EXPERIMENTAL WORK

Fig. 1 is a schematic representation of the experimental set up which consists of a double compartment MFC. The two compartments were placed in water bath to maintain the solution's temperature at the required value. One compartment contains the anolyte of yeast microorganism of different concentrations with 0.1N NaCl solution. The other compartment contains the catholyte which is 0.1N NaCl solution. Firstly, copper was investigated as an anode and cathode then then aluminum was used. The electrodes were cut as thin coupons of dimensions 40×40 mm. One face of coupons was exposed to the solutions while the other face was completely insulated. Zero resistance ammeter ZAR was used for measuring the produced current and standard calomel electrode (SCE) for measuring the electrodes potentials. A pH meter was employed for solution pH measurements. Before adding the microorganism to the solution, the current was ensured to be zero between the two compartments containing only 0.1N NaCl solution. Then, the yeast microorganism of different amounts was added without substrate and the produced current was recorded with time. The glucose as a substrate was added in different amounts. Yeast is heterotrophic and it ingests food from the surrounding. It is unable produce food but it grows on organic feedstocks that possess competing uses in the production of food (Gassler et al., 2019). The anode chamber consisted of copper (or aluminum) electrode of exposed area 1600 mm². It was filled with 1.5 liter of 0.1N NaCl solution containing different concentrations of yeast microorganism. Cathode chamber consisted of copper electrode of an area of 1600 mm². The cathode chamber was filled with 1.5 liter of 0.1N NaCl solution. The electrodes were hold in the solution by fixing them on a plastic board. The anode and cathode chambers were connected by salt bridge filled with 0.4N NaCl solutions. The distance between electrodes is affixed on 120 mm. An external wire was used to electrically connect the two chambers. Before connecting the MFC, the open circuit potential of each electrode was measured with time for the different conditions investigated to understand its behavior with operating parameters. Concentrations range of microorganism (yeast) from 0 to 6 g/l was studied to examine the values of current produced and trends of electrode potentials for 60 minutes time duration for temperature range of 33-45 °C. The pH of solutions in both chambers was measured along the test interval and found to be around 7. Glucose was added to the solution that contains yeast and left for half an hour before starting the run to study its effect on the produced current. Both chambers were open to atmosphere. Each experiment was repeated 3 times to ensure the results reproducibility.

Corrosion tests of copper and aluminum was performed to determine the corrosion rate for examining electrodes efficiency. The corrosion rate of each electrode (Cu and Al) was

determined using weight loss method in selected most corrosive operating conditions. To determine the corrosion rate, the test samples were prepared according to the standard procedure for sample preparation for corrosion tests (Shreir, 2000; Fontana, 2017). The corrosion rate was determined by weighting the specimen before the corrosion test using sensitive digital balance (accuracy 0.1 mg). Each specimen was immersed in the solution containing 2 g/l yeast, 3 g/l glucose, 0.1N NaCl at 36 °C for 4 hours. After the corrosion test, the specimens were cleaned, dried, and weighed to determine the loss in weight due to corrosion (Slaiman et al., 2008; Hasan and Aziz, 2017). Each experiment was repeated twice. No appreciable weight loss was noticed for both metals.

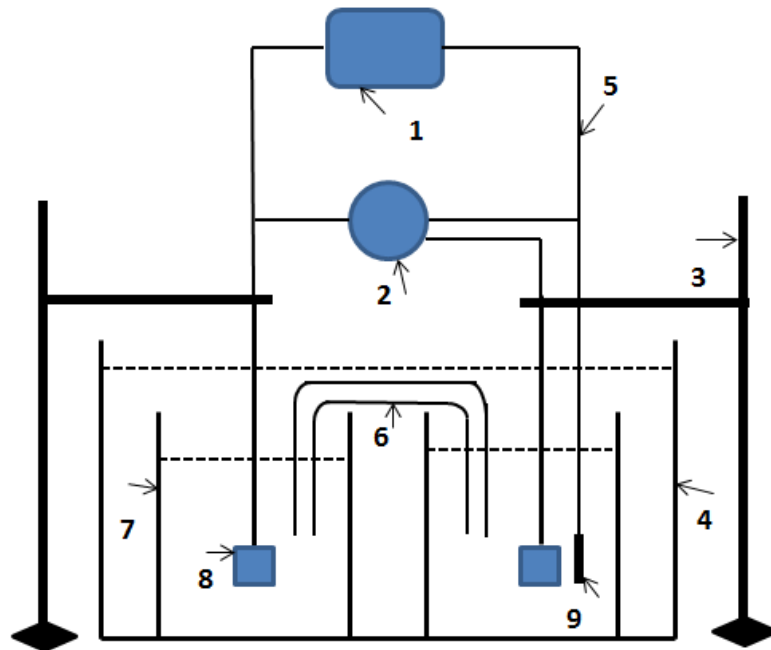

Figure. 1. Experimental set up: 1. Zero Resistance Ammeter, 2. Voltmeter, 3. Stand, 4. Water bath, 5. Copper wire, 6. Salt bridge, 7. Beakers, 8. Electrode (Cu or Al), 9. Reference electrode (SCE).

3. RESULTS AND DISCUSSION

Both copper (Cu) and aluminum (Al) are used to as electrode for the MFC under different operating conditions and the results are presented in this section.

3.1 Effect of Microorganism (MO) Concentration

Various amounts of biomass were added to the anode compartment to determine the values of produced current. Electrode potential influences the oxidation process of microorganism (MO) that results in a current flowing in the circuit. It is interesting to investigate the variation of electrode potentials with the operating parameters to understand its effect of produced current.

Fig. 2 and **3** show the influence of the microorganism (yeast) concentrations on the open circuit potentials for copper and aluminum electrodes. It can be seen that the increase in microorganism concentration leads to shift the potential to more negative direction. The shift of potential to more negative with increasing MO concentration leads to increase the

potential difference between the two poles of the cell. This leads to generate a current between the two terminals. In general for a particular MO concentration, the potential is also shifted to more negative with time. This is ascribed to the occurrence of resistance polarization due to the formation of oxide film and biomass deposits (biofilm) on the electrode surface. The formation of oxide film on the electrode surface when there is no MO and deposits when MO is present, causes an increase in the electrical resistance between the solution and the electrode surface. This leads to a departure of electrode potential from the equilibrium potential which appears as a negative trend of the potential measured by the reference electrode (**Hasan, 2010; Fontana, 2017**).

Fig. 4 compares the trends of open circuit potential (OCP) of copper (Cu) and aluminum (Al) electrodes immersed in a solution containing different concentrations of yeast microorganism at



33 °C. These figures indicate that the copper electrode exhibits much higher potential than the aluminum electrode in different solution concentrations of microorganism. This indicates the higher electrochemical characteristics of Cu than Al in the relation to oxidation of microorganism.

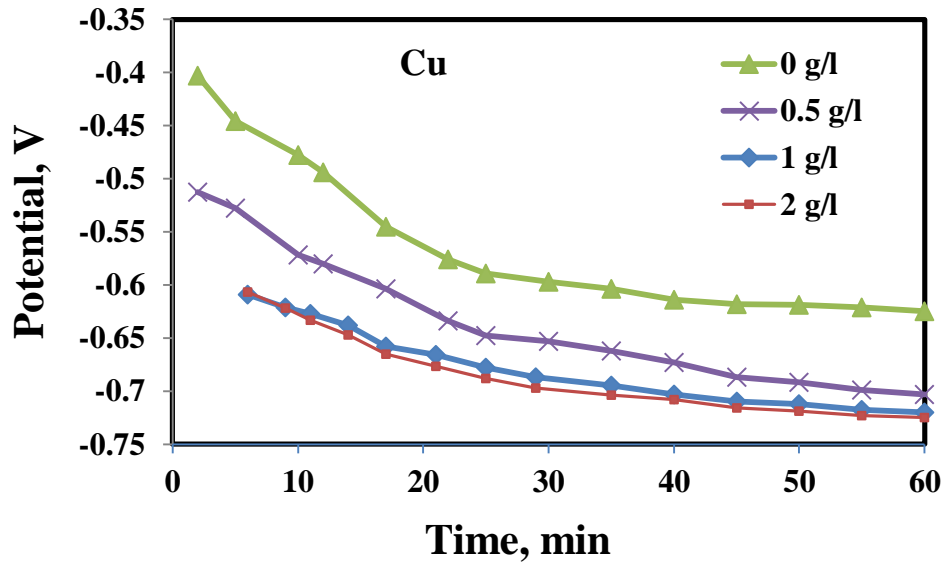

Figure 2. OCP of copper electrode versus time for different MO concentrations at T=33 °C.

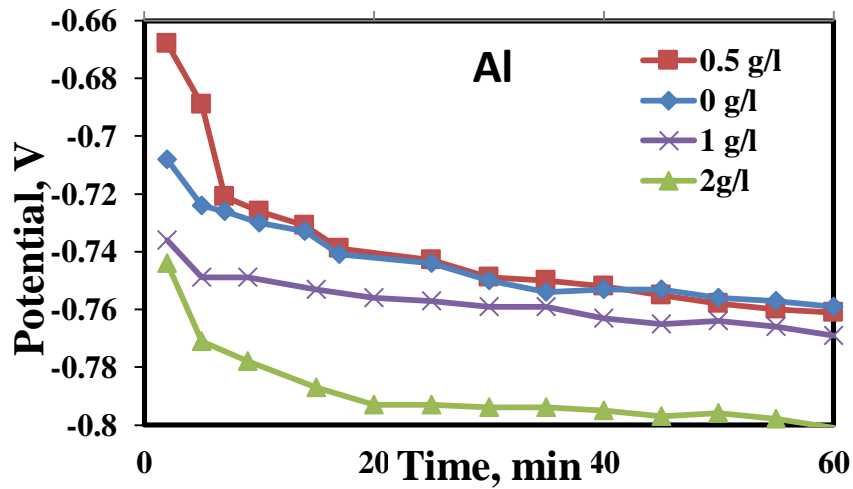

Figure 3. OCP of aluminum electrode versus time for different MO concentrations at T=33 °C.

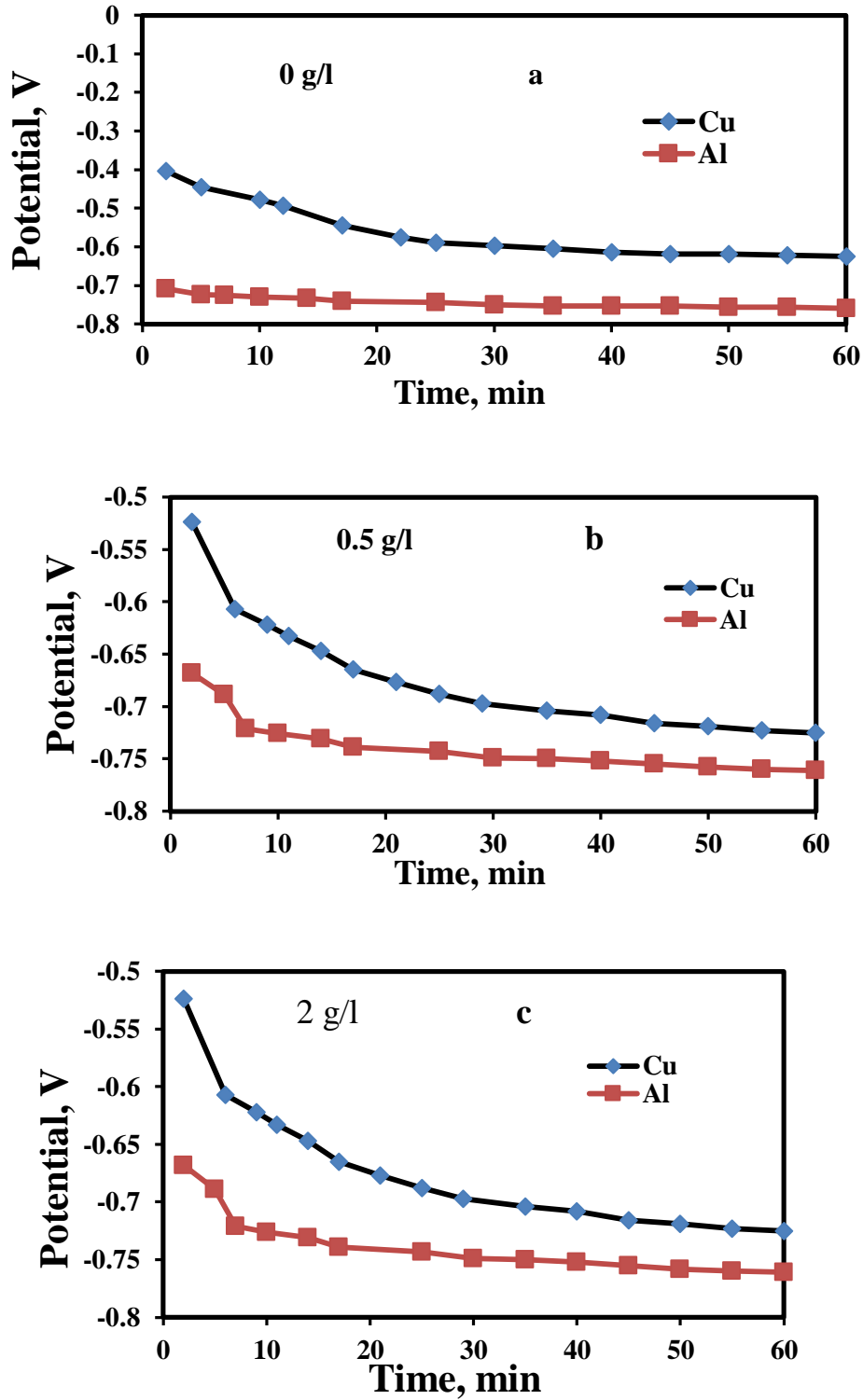

Figure 4. OCP of Cu and Al electrodes for different concentrations of yeast MO at 33 °C, (a) no MO, (b) 0.5 g/l MO, (c) 1 g/l.



3.2 Produced Bio-Current

Fig. 5 shows the produced current versus time for copper electrode for different MO concentrations. It can be seen that the current increases with time. This is due to the increased metabolism activity of the bacteria producing more electron which transfers to the cathode compartment where the dissolved O₂ is reduced. Fig. 5 also shows that the produced current increases with increasing of MO concentration up to 6 g/l. The increase in the bio-current with MO concentration is due to the increased contact between MO and the electrode with causes an increase in oxidation process of MO. Fig. 6 for aluminum electrode shows almost the same trend except that at high concentration of 6 g/l MO, the current becomes less. This can be ascribed to the increased accumulation of MO on the electrode surface which increases the surface resistance to the current flow because of the formation of bio-fouling layer on that surface. Some previous authors (Picioeanu, et.al. 2007; Ren, et.al. 2011) have reported that the presence of biofilm restrains the elections passage to the electrode and thus the current decreases. The irregularity in the current behavior with time in Figs. 5 and 6 is ascribed to the fact that the current flowing in the cell is influenced by several factors such as potential difference, the non-uniform distribution of the deposits on the surface, the surface morphology, and the probability of oxidation and reduction reactions on both anode and cathode. All these factors cause some scattering of the data points.

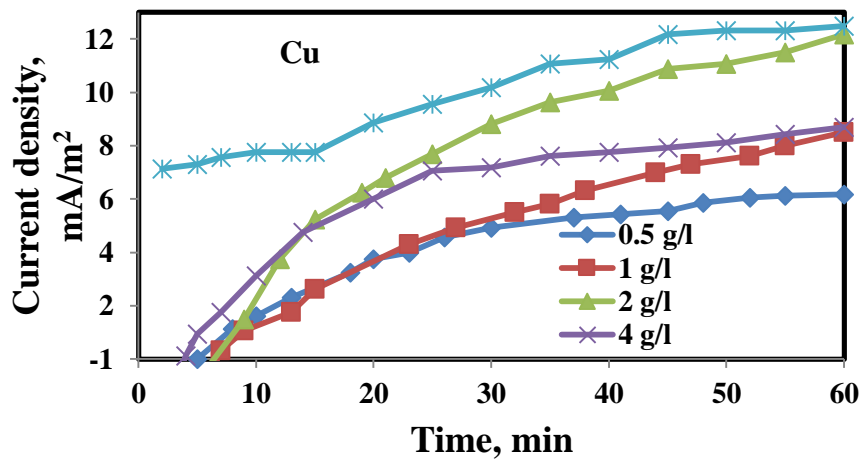

Figure 5. Current density versus time for copper electrode at 33 °C, at different concentrations of MO.

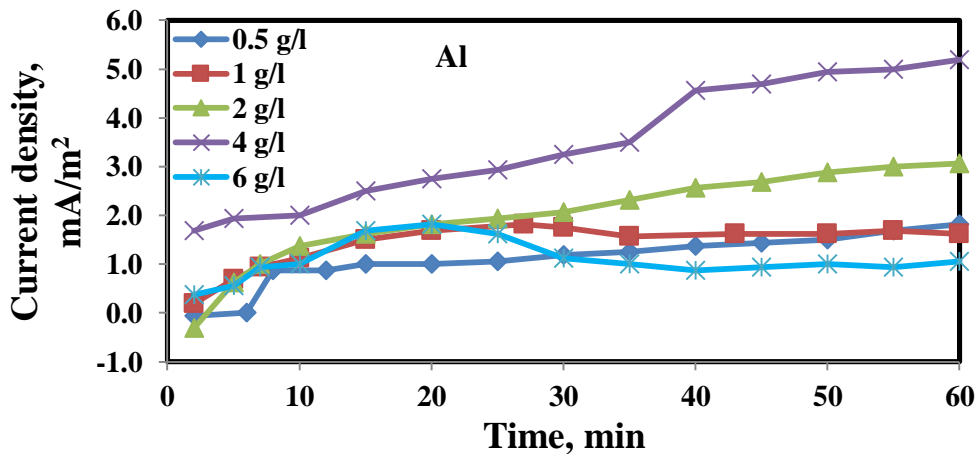
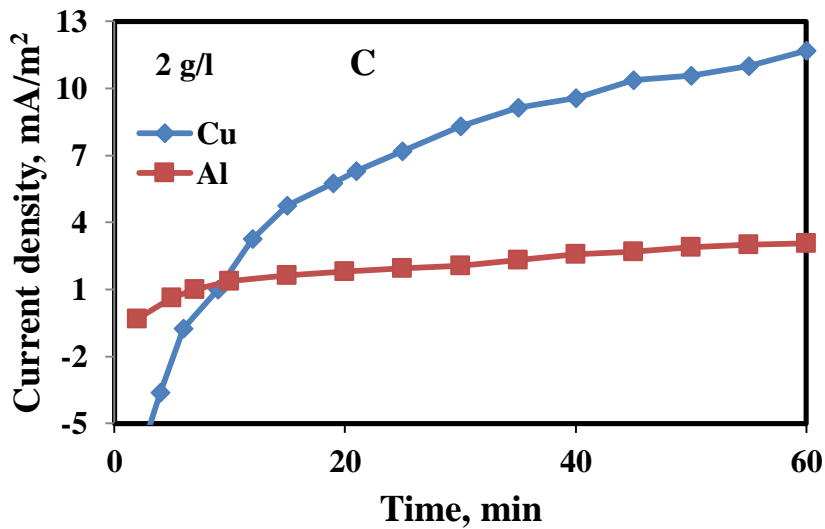
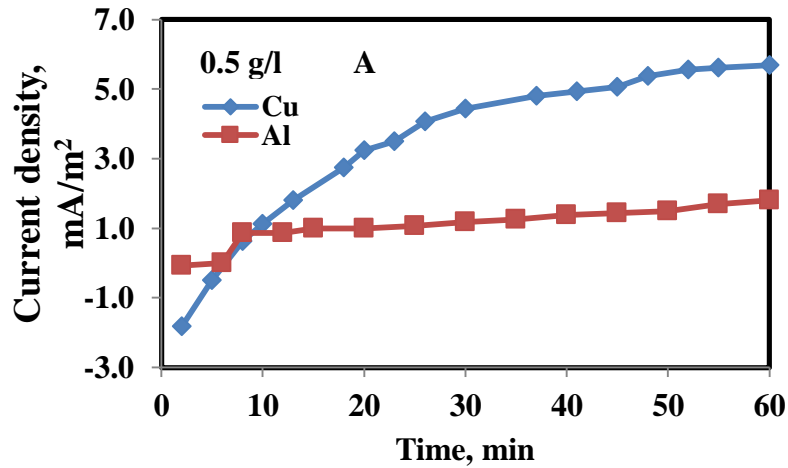

Figure 6. Current density versus time for aluminum electrode at 33 °C, at different concentrations of MO.



Fig. 7 compares the current produced when using the two electrode materials copper and aluminum for different MO concentrations. It is evident that, generally, the current produced on Cu electrodes is much higher than that of Al. This is ascribed to different reasons such as the higher electrical conductivity of copper and higher electrode potential (as shown in **Fig. 4**) which facilitates the oxidation of microorganisms. Other factor may also play a role that is the surface morphology and adhesion properties which give a chance to the microorganism to stick on the surface for longer time interval. It can be seen that the difference between the values of produced current reaches to 12 times higher on copper electrode than on aluminum electrode for MO concentration of 6 g/l.



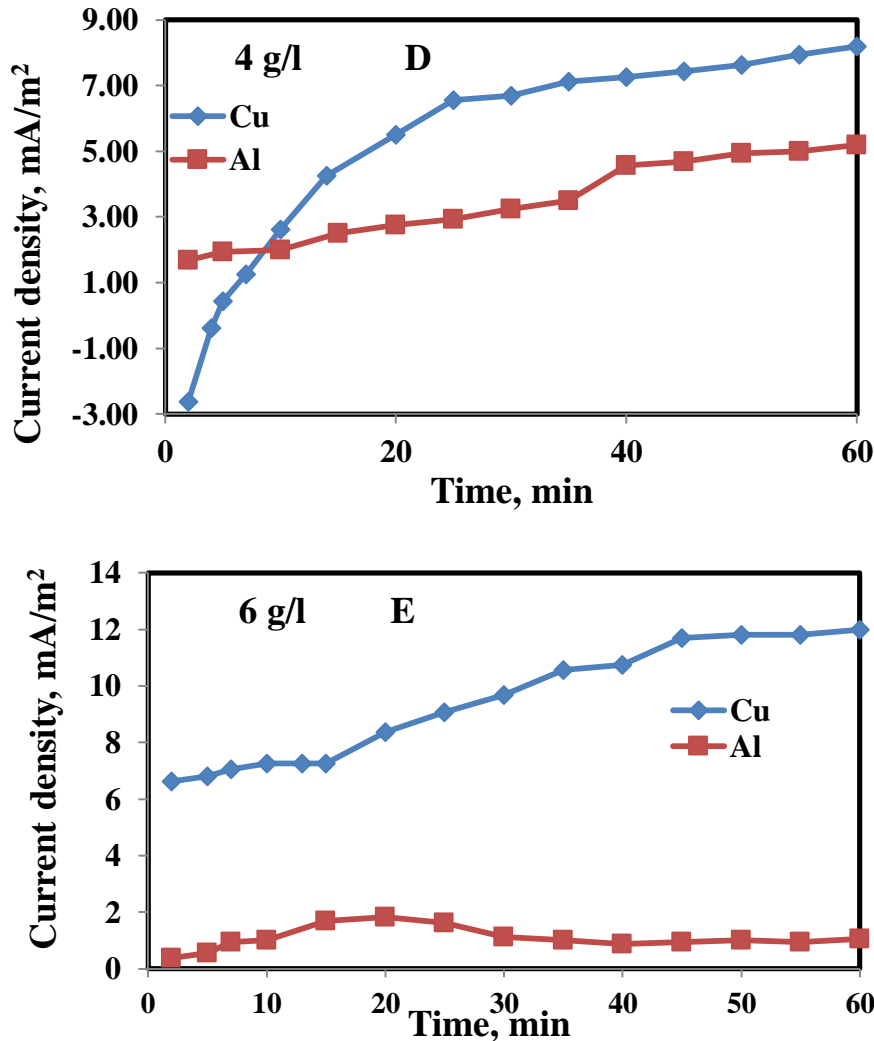

Figure. 7. Performance of electrode type in galvanic cell, $T=33\text{ }^{\circ}\text{C}$ and different MO concentrations. (A) 0.5 g/l, (B) 1 g/l, (C) 2 g/l, (D) 4 g/l, (E) 6 g/l.

3.3 Effect of Temperature

Fig. 8 presents the effect of temperature on the generated current for 2 g/l MO concentration. It can be seen that the produced current is highest for $T=36\text{ }^{\circ}\text{C}$. With further increase of solution temperature, the current decreases. This behavior is attributed to MO activity. The microbial activity reaches the peak when the temperature increased to $36\text{ }^{\circ}\text{C}$ that accelerates the oxidation rate and liberation of electrons from the microorganism and reduce the activation energy required. (Min, et al., 2008) found that at $15\text{ }^{\circ}\text{C}$, the performance of MFC is weak. The authors reported that the maximum OCP is increased by 4.8% when the temperature increases from $30\text{ }^{\circ}\text{C}$ to $35\text{ }^{\circ}\text{C}$. This was due to that the energy cannot be maximized to improve by temperature increase. Microbes were noticed to have an optimum activity at temperature of $35\text{ }^{\circ}\text{C}$. Above this temperature it will start to die (Tang, et al. 2012).

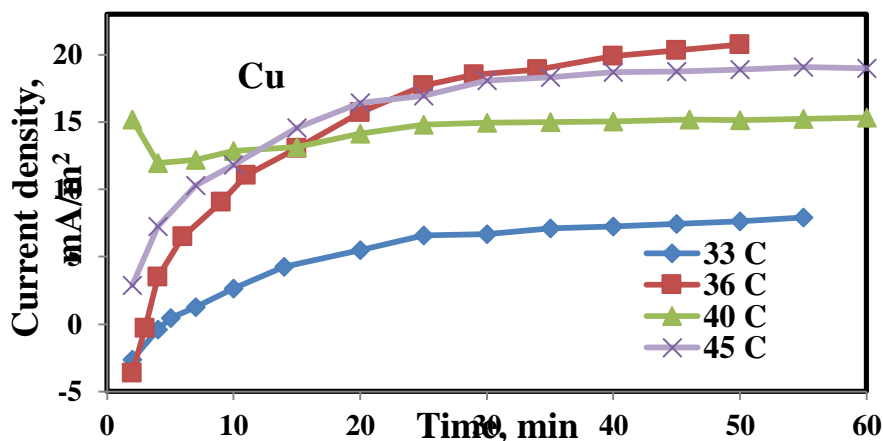

Figure. 8. The effect of temperature on current at 2 g/l MO concentration.

3.4 Effect of Substrate (Glucose) Addition

Fig. 9 shows the effect of substrate (glucose) concentrations on the potential of copper anode. It is clear that increasing the substrate concentration causes a noticeable shift of the potential to more positive direction. This is attributed to the formation of hydrogen ion (H^+) due to the degradation of hydrocarbons by the microorganisms according to Eq. (1). The formation of H^+ means more acidic solution which causes an increase in the potential. Highest increase in potential is in the case of 6 g/l glucose. The trend of electrode potential has a direct effect on the bio-current produced. Fig. 10 shows the effect of adding glucose substrate to the MO solution on the produced current when the concentration of MO is 2 g/l. It is clear that increasing glucose amount up to 3 g/l causes an increase in the MO activity which degrades the biomass resulting in more electrons according to Eq. (1). From Fig. 10, adding 3 g/l glucose increases the current by an average of 5.5 times. Further increase in substrate concentration to 6 g/l causes a clear reduction in the produced current.

The decrease in the current with large increase in glucose concentration can be ascribed to (i) the increased solution viscosity which restrains the microorganism movement toward the

electrode, (ii) deposition or adhesion of glucose on the electrode surface which increases the electrical resistance at the surface, (iii) reduction in the potential difference between cathode and anode because of the increased potential of anode due the formation of excessive amount of H^+ .

Overall, the optimum operating conditions for obtaining the maximum power input are: use of copper electrode, $T=36\text{ }^\circ\text{C}$, MO concentration of 6 g/l, and substrate (glucose) concentration of 3 g/l.

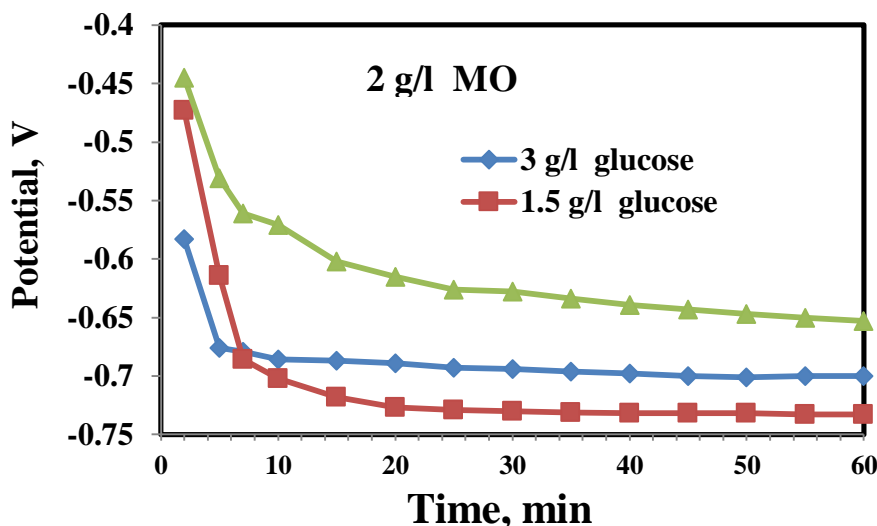

Figure 9. Effect of glucose on anode potential at 33 C, 2 g/l MO using copper electrode.

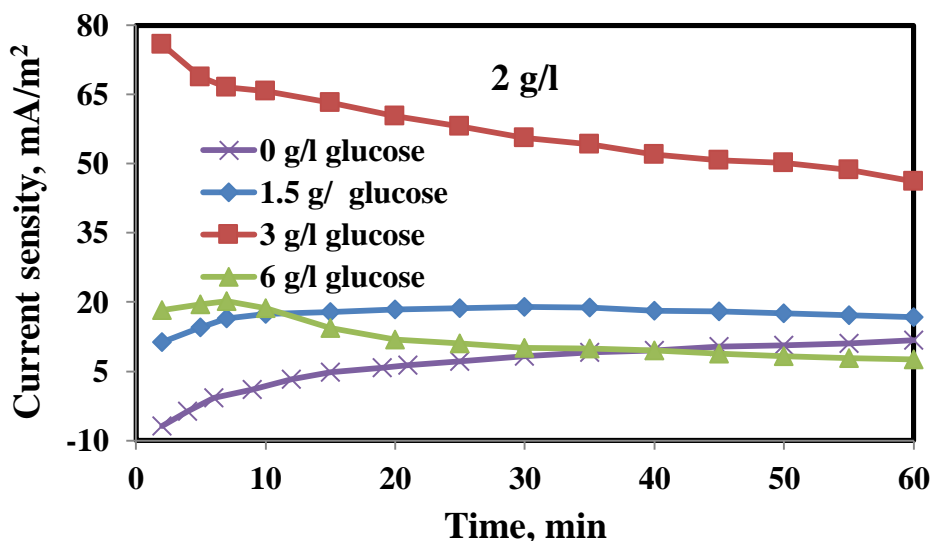

Figure 10. Effect of glucose on current of microbial fuel cell at 33 °C, 2 g/l MO using copper electrodes.

4. CONCLUSIONS

The following conclusions can be drawn from the results obtained:

- 1- The bio-electricity produced using copper electrode is considerably higher than that using aluminum electrode. This is mainly due to the superior electrochemical properties of copper compared to aluminum.
- 2- The increase in the concentration of yeast MO from 0.5 to 2 g/l, the current density increased by 4.5 times for copper electrode and 3.8 times for aluminum electrode.
- 3- Highest electricity is obtained when operating the yeast MFC at 36 °C.
- 4- Adding glucose as a substrate increases the produced current. Increasing the glucose substrate concentration from 0 g/l to 3 g/l, increases the bio-current by 5.5 times. Further increase of glucose concentration reduces the produced current.
- 5- The potential of each electrode is a direct function of MO activity and substrate concentrations. The presence of yeast MO in the anode chamber shifts the potential of anode to



more negative; the factor that increases the current production by increasing the potential difference between the electrodes of MFC

REFERENCES

- Ali, A.H., Al-Mussawy, H.A., Hussein M. J. and Hamadi N.J., 2018. Experimental and Theoretical Study on the Ability of Microbial Fuel Cell for Electricity Generation”, *Pollution*, 4(2), pp., 359–368.
- Baudler, A., Igor Schmidt, Markus Langner, Andreas Greiner, Uwe Schroöder, 2015. Does it have to be carbon? Metal anodes in microbial fuel cells and related bio-electrochemical systems, *Energy Environ. Sci.*, 2015, 8, 2048.
- Fontana, M G., *Corrosion Engineering*, 3rd Edition, McGraw Hill, USA, 2017.
- Gassler, T., M. Sauer, B. Gasser, M. Egermeier, C. Troyer , T. Causon, S. Hann, D. Mattanovich, M. G. Steiger, The industrial yeast *Pichia pastoris* is converted from a heterotroph into an autotroph capable of growth on CO₂, *Nature Biotechnology*, 2019.
- Ghoreyshi A., Jafary T., Najafpour G.D., Haghparast F., 2011. Effect of type and concentration of substrate on power generation in a dual chambered microbial fuel cell, *World Renewable Energy Congress - Sweden*; 8-13 May, Linköping, Sweden.
- Guerrero L., Scott K., Head I.M., Mateo F., Ginesta A., Godinez C., 2010. Effect of temperature on the performance of microbial fuel cells”, *Fuel* 89, pp., 3985-3994.
- Hasan, B. O., 2010. Effect of salt content on the corrosion rate of steel pipe in turbulently flowing solutions, *Al-Nahrain Journal for Engineering Sciences*, 13, 66-73.
- Hasan, B. O., Aziz, S. M., 2017. Corrosion of carbon steel in two phase flow (CO₂ gas-CaCO₃ solution) controlled by sacrificial anode, *Journal of Natural Gas Science and Engineering*, 46 (71-79).
- Ismail Z. Z. and Jaeel, A. J. 2013, Simultaneous Electricity Production and Wastewater Treatment in a Microbial Fuel Cell Inoculated with Anaerobic Sludge”, *Journal of Engineering*, 19 (8), PP. 1031-1038.
- Ismail Z. Z. and Mohammed A. J., 2017, Biotreatment of Slaughterhouse Wastewater Accompanied with Electricity Generation and Nutrients Recovery in Microbial Fuel Cell”, *Journal of Engineering*, 23(5), PP. 94-105.
- Jadhav, G. S. , M. M. Ghangrekar, 2009. Performance of microbial fuel cell subjected to variation in pH, temperature, external load and substrate concentration *Bioresource Technology*, 100, pp., 717–723.
- Jiang, M. T.Xu, S. Chen, 2020. A mechanical rechargeable small-size microbial fuel cell with long-term and stable power output, *Applied Energy* 260, 114336.
- Jong C., Kim B. H., Chang I. S., Liew P. W.Y., Choo Y. F., Kang G. S., 2006. Enrichment, Performance, and Microbial Diversity of a Thermophilic Mediatorless Microbial Fuel Cell”, *Environmental Science and Technology*, 40(20),6449-6454.
- Khudzaria, J. M., Y. Gariyepya, J. Kuriana, B. Tartakovskya, 2019. Effects of biochar anodes in rice plant microbial fuel cells on the production of bioelectricity, biomass, and methane, *Biochemical Engineering Journal* 141, 190–199
- Lapidou S., Rittmann B. E., 2004. Modeling biofilm complexity by including active and inert biomass and extracellular polymeric substances”, *Biofilms* , pp., 285–291.
- Li, L. H., Sun Y. M., Yuan Z. H., Kong X. Y. and Li Y., 2013. Effect of temperature change on power generation of microbial fuel “*Environmental Technology*, 34(13-14), pp., 1929-1934.
- Liu, D., Qinghuan Chang, Y. Gao, W. Huang, Z. Sun, Mei Yan, C. Guo, 2020. High performance of microbial fuel cell afforded by metallic tungsten carbide decorated carbon cloth anode, *Electrochimica Acta* 330,135243



- Marcus, A. K., Torres, C. I., Rittmann, B. E., 2007. Conduction-based modeling of the biofilm anode of a microbial fuel cell". *Biotechnology and Bioengineering*, 98(6), pp., 1171–1182.
- Min., Roman O. B., Angelidaki I., 2008. Importance of temperature and anodic medium composition on microbial fuel cell (MFC) performance “; *Biotechnol Lett.*, 30(7) 1213-1218.
- Moawad Y., 2013.” Growth Energy of Bacteria and the Associated Electricity Generation in Fuel Cells”, *Bioengineering and Bioscience*, 1 (1), pp.,5 -10.
- Mustakeem, M., 2015. Electrode materials for microbial fuel cells: nanomaterial approach”, *Materials for Renewable and Sustainable Energy*, 4(22) 1-11.
- Oh S., B. Min and B.E. Logan, 2004. Cathode performance as a factor in Electricity generation in microbial fuel cell, *Environmental Science and Technology*, 38(18), pp., 4900-4904.
- Picioreanu, I. M. Head, K. P. Katuri, M. C. M. Van Loosdrecht, 2007. ”A computational model for biofilm-based microbial fuel cells”, *water research*, 41, 2921-2940.
- Rahimnejad M., Najafpour G., Ghoreyshi A. A., 2011. Effect of mass transfer on performance of microbial fuel cell, *Mass transfer in Chemical Engineering Processes*, ISBN: 978-953-307-619-5.
- Ren Z., Ramasamy R. P., Owen S. R. C., Yan H., Mench M. M., 2011.” Time-course correlation of biofilm properties and electrochemical performance in single-chamber microbial fuel cells, *Bioresource Technology*, 102, pp., 416-421.
- Sanchez V. P., May, 2013. Understanding the influence of the electrode material on microbial fuel cell performance, 30-38.
- Shreir, L. L., *Corrosion: Metal- Environment Reactions*, 2nd Edition, Butterworth, USA, 2000.
- Slaiman, Q.J. M, BO Hasan, HA Mahmood, Corrosion inhibition of carbon steel under two-phase flow (water-petroleum) simulated by turbulently agitated system; *The Canadian Journal of Chemical Engineering*; 2008 (2), 86; 240-248.
- Tang, Y. L., Y. T., He, P. F. Yu 2012. Effect of temperature on electricity generation of single-chamber microbial fuel cells with proton exchange membrane, *Advanced Materials Research*, 393-395, 1169-1172.
- Torres, A. K., Marcus, H. S., Lee, P., Parameswaran, R. K.-B., Rittmann, B. E., 2010. A kinetic perspective on extracellular electron transfer by anode-respiring bacteria. *FEMS Microbiology Reviews*, 34, pp., 3–17.
- Wei, J., Liang P., Huang X., 2011. Recent progress in electrodes for microbial fuel cells”, *Bioresource Technology*, 102(20), 9335-9344.