

Design and Simulation of a controller for Double Fed Induction Generator turbine Utilized Solar Up Draft Tower

Mayada Yousif Heelan*

M.Sc. student

Department of Electrical Engineering

College of Engineering/ University of Baghdad

E-mail: mayada.hstd@uob.edu.iq

Dr. Fadhil Abbas M. Al-Qrimli

Department of Electrical Engineering

College of Engineering/ University of Baghdad

E-mail: fadhil@uob.edu.iq

ABSTRACT

This paper introduces a complete design and simulation of a controller for the double fed induction generator (DFIG) turbine. The work also included the solar updraft tower (SUT) design to supply Al-Mahmoudia hospital in Baghdad/Iraq. The design includes the daily average load estimation, annual solar irradiance and, temperature monitoring, and logging. According to the data obtained from the Ministry of Science and Technology, Baghdad has low wind speed. Therefore, the (SUT) has been designed to generate electrical power depending on the difference between the external and internal air temperature. The temperature difference will generate a suitable airspeed to drive the wind turbine, connected to the proposed (DFIG) generators that generate the appropriate electrical power required. The proposed controller of the DFIG is based on (vector control) by using PI control to feed the power of the rotor circuit parts. The (DFIG) consists of two back-to-back PWM inverters connected between the stator and the rotor. This paper's main goal is to design and simulate a controller for two (DFIG's) under various operating conditions driven by a wind turbine, which is rotated by the warm wind effect inside the solar updraft tower. This is to generate maximum power with constant magnitude and frequency of the output voltage. The proposed controller's performance is verified by using a simulation model built using the MATLAB/Simulink software. The simulation results confirm that the proposed controller (Vector Control), using PI controller maintains both the magnitude and frequency of the output voltage stays constant at the nominal values and stabilization irrespective of the wind speed variations and extract maximum output power. In addition, the controller provides (MPPT) to the turbine to generate the maximum power according to the available wind speed. The torque will give the rotor quadrature current (I_{qr}), which causes speed change according to the working conditions. The results also showed the steady-state and discussed the two different methods (Vector Control, MPPT) of the control strategy (DFIG). MATLAB and Simulink software used for modeling one of DFIG's modules to supply the hospital load of 276 KW. Besides, simulation results show that the controller demonstrates significant improvements in terms of better stability and faster response.

*Corresponding author

Peer review under the responsibility of University of Baghdad.

<https://doi.org/10.31026/j.eng.2021.03.03>

2520-3339 © 2019 University of Baghdad. Production and hosting by Journal of Engineering.

This is an open access article under the CC BY4 license <http://creativecommons.org/licenses/by/4.0/>.

Article received: 25/7/2020

Article accepted: 20/10/2020

Article published: 1/3/2021



Keywords: Renewable energy, Solar updraft tower, DFIG, PI controller, vector controller, MATLAB/Simulink.

د. فاضل عباس القرملي دكتوراه قسم الهندسة الكهربائية كلية الهندسة/ جامعة بغداد	ميادة يوسف هيلان* طالبة ماجستير قسم الهندسة الكهربائية كلية الهندسة/ جامعة بغداد
--	---

الخلاصة

تقدم هذه الورقة تصميم ومحاكاة كاملة لوحدة تحكم لتوربين مولد الحث المزدوج (DFIG). كما تضمن العمل تصميم برج التحديث الشمسي لتزويد مستشفى المحمودية ببغداد/ العراق. يشمل التصميم أيضاً متوسط تقدير الحمل اليومي والإشعاع الشمسي السنوي ومراقبة درجة الحرارة وتسجيلها. بسبب انخفاض سرعة الرياح في العراق، وخاصة في بغداد، ووفقاً لقيم بيانات الرياح المعتمدة من قبل أقسام العلوم والتكنولوجيا. ولهذا السبب، تم تصميم (SUT) واستخدامه لتوليد الطاقة الكهربائية يعتمد على الاختلاف بين درجة حرارة الهواء الخارجية والداخلية. سيولد هذا الاختلاف في درجة الحرارة سرعة الهواء لتشغيل عنفات الرياح المتصلة بالمولدات وتوليد الطاقة الكهربائية المناسبة بعد التحكم في DFIG المقترح. تعتمد وحدة التحكم المقترحة في DFIG (التحكم الإشعاعي) باستخدام عنصر التحكم PI لتغذية جزء من الطاقة إلى دائرة الدوار. يتكون (DFIG) من عاكسين PWM متاليين متصلين بين الجزء الثابت والدوار. الهدف الرئيسي من هذا التصميم في هذا البحث، محاكاة وحدة التحكم لمولدات الحث ذات التغذية المزدوجة (DFIG's) في ظل ظروف تشغيل المختلفة يتم تشغيلها بواسطة عنفات الرياح التي يتم تدويرها بواسطة تأثير الرياح الدافئة داخل برج التحديث الشمسي لتوليد أقصى قدر من الطاقة مع قيمة ثابتة للتردد وجهد الخرج. يتم التحقق من أداء وحدة التحكم المقترحة باستخدام نموذج محاكاة أنشأ باستخدام MATLAB/Simulink. تؤكد نتائج المحاكاة أن التحكم المقترح (التحكم الإشعاعي) باستخدام جهاز التحكم PI يحافظ على كل من قيمة وتكرار جهد الخرج يبقى ثابتاً عند القيم الاسمية والاستقرار بغض النظر عن اختلافات سرعة الرياح وإستخراج أقصى طاقة خرج. بالإضافة إلى ذلك، توفر وحدة التحكم (MPPT) للتوربين لتوليد الطاقة القصوى وفقاً لسرعة الرياح المتاحة. سيعطي عزم الدوران تيار الجزء الدوار من المولد (Iqr)، والذي يتسبب في تغيير السرعة وفقاً لظروف العمل. كما سنعرض نتائج الحالة المستقرة وناقش الطريقتين المختلفتين لاستراتيجية التحكم لـ (DFIG). تم استخدام برامج MATLAB/Simulink لنمذجة إحدى وحدات DFIGs لتزويد حمولة المستشفى بطاقة 276 كيلو واط. بالإضافة إلى نمذجة وحدة التحكم المقترحة (التحكم الإشعاعي) حيث نلاحظ الأداء المحسن لوحدة التحكم المقترحة من حيث الاستقرار الأفضل والاستجابة الأسرع.

1. INTRODUCTION

The solar updraft tower (SUT) system is one of the renewable energy power systems. The air will be heated inside the greenhouse (air collector), and the result of this heating causes the airflow to the center of the collector and goes up through the central tower. This moving air will drive the turbine connected to the generator to produce electrical power. There are three components of this system, as shown in **Fig.1**

- The air collector has been covered with transparent glass to absorb the heat.
- A tall tower (chimney) is installed in the center of the collector.
- Air turbines are installed in the base of the tower.

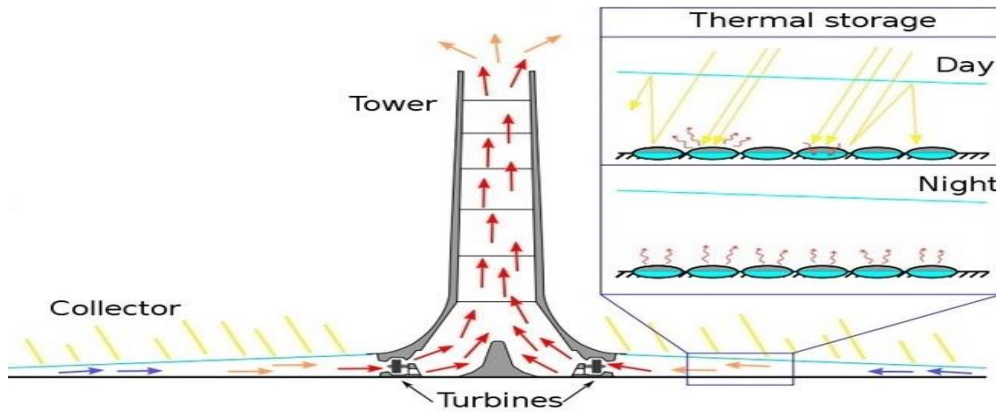

Figure 1. The working principle of the updraft tower with the thermal storage working as a heat sink.

As shown in **Fig.1**, (Gu'nther, H., 1931), (Schlaich, J., and Schiel, W., 2001), air will be heated because of the solar radiation inside the air collector that has many holes along the circumference. When the air temperature becomes high, the air will expand, and its density becomes low. As the hot air density is less than the density of the cold air, the air rises to the top of the tower due to the buoyancy force. The energy of the buoyancy work of the updraft air will be converted into mechanical energy by the turbine's rotation and will be converted to electrical energy by the generator rotation. Continuous 24 hours of operation will be achieved by putting tubes or bags filled with water on the ground inside the collector, as shown in **Fig.2**. The water heats up during the daytime and releases its heat after sunset. These tubes are filled one time only; no further water is required.

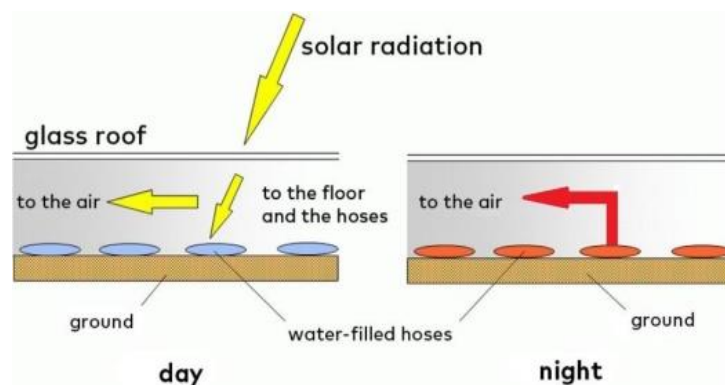

Figure.2. Principle of the thermal energy storage with water-filled tubes.

This design's idea is inspired by the design and construction of the solar updraft tower in Manzanares and Enviromission (Schlaich, J., et al., 1995), (F. Denantes and E. Bilgen, 2006). This is used to produce electrical energy for this type in which one wind turbine is used, and some designs use two turbines and other designs that use more than two turbines. This depends on how much electrical energy produced from the generators connected to the wind turbine inside the collector to feed the load. As for this design, two vertical axis wind turbines were used in the towered neck due to the amount of electrical power needed to feed the required load. Both turbines will work at certain hours to feed the loads, and at the rest of the hours, they will run one of the



turbines and turn off the other because the required load will decrease as found in (G.Schwarz and H.Knauss,1981), (J.Schlaich, 1995). There are different types of generators to be driven by wind turbines used inside the solar updraft tower. Wind turbines can either operate at variable speed (wound rotor, double fed induction generator is proposed) or fixed speed (Ruviaro, M., et al., 2012), (Madawala, U. K., et al., 2012). For a variable speed wind turbine, the generator is controlled by power electronic converter equipment. There are several reasons for using variable speed operation of wind turbines; among those are possibilities to reduce mechanical structure stresses, acoustic noise reduction, and the possibility to control active power. Then maintained voltage frequency in the stator winding constant. It is preferable to run the wind energy generator system at variable generator speed to maximize the captured wind power inside the solar updraft tower (Li, H., and Chen, Z, 2008). Harvesting maximum power with maintained constant voltage and frequency in the double fed induction generator (DFIG) stator winding under specific operation circumstances using (vector control) by PI control is very important to control the two back-to-back converters in the DFIG system. The work by (L. Whei-Min., et al., 2011) is less attractive due to the Squirrel Cage Induction Generator (SCIG), so the power quality is not considered. Another scheme has been proposed in (A. Ahmed, R. Li., et al., 2013), which is offer better efficiency, but economically it is expensive due to the size of the power electronics converters used to control the Permanent Magnetic Synchronous Generator (PMSG). In that research work, authors have achieved their objectives. Still, the installation cost is increased due to the high rating of the power converters for controlling generators, according to the comparative study with the previous of the power converters for variable speed wind turbine (WT) with the work presented in (F. Blaabjerg., et al., 2012). DFIG has a good performance compared with the SCIG and PMSG. The profitability of the variable speed WT based on the DFIG is confirmed in (V. C. Ganti, at el., 2012) to remedy these weaknesses and increase the system efficiency. Another advantage of using DFIG is controlling (25-30)% of the total power of power electronics converters, which is reducing the cost of these converters. It also enhances the performance of the ac mains network and its power factor (p.f.). The voltage and frequency of the stator windings are constant regardless of the wind turbine's speed change. These benefits give an attraction to make the proposed work in this paper using the DFIG in the solar updraft tower to produce electrical power. Researchers use this method to control the (DFIG) is also easy to implement and experimentally easy to use. The PI controller is used for vector control strategy to control the DFIG. This controller is simpler than artificial intelligent controllers. This is very effective in terms of control results and efficiency. These circumstances are solar radiation, ambient temperature, airspeed, and the load (Pena, R., et al., 1996), (Abad, G., et al., 2011). This paper's main objective is to design and control simulation doubly-fed induction generators (DFIGs) under various operating conditions to be driven by the wind turbine. This is rotated by the warm wind effect inside solar updraft tower generating maximum power at constant magnitude and frequency of the output voltage that fed to the load and designed the (SUT).

1. SOLAR UPDRAFT TOWER (SUT) POWER SYSTEM DESIGN

Design of (SUT) that rotates a wind turbine connected to DFIGs generates. The power from the two generators is controlled under various operating conditions for a certain application requires



an accurate estimation of the daily, monthly, and annual load of that application. Because the load is not changing either monthly or annually, only a daily load estimation is required for the application under study (Al-Mahmoudia hospital). The designing steps are explained for the (SUT) power system, design, and control of the double fed induction generator.

1.1 AL-Mahmoudia Hospital Load Estimation.

The daily load power demand per hour obtained of Al-Mahmoudia hospital, as shown in **Fig.3**. This is real data obtained from the Ministry of Health/ Al-Mahmoudia hospital. This data used to determine the size of the power of (DFIG) required inside (SUT) power system.

1.2 Study Of Climatic Conditions Of Hospital Place.

The global positioning system (GPS) gives the hospital's latitudinal and longitudinal coordinates at 33.31degree and 44.33 degrees, respectively. The available governmental data about solar irradiance and the hospital place's temperature was acquired from the Iraqi weather forecast/Renewable Energy and Technology Center. **Figs 4** and **5** below show solar irradiance and temperature variations during typical selected summer and winter days, respectively.

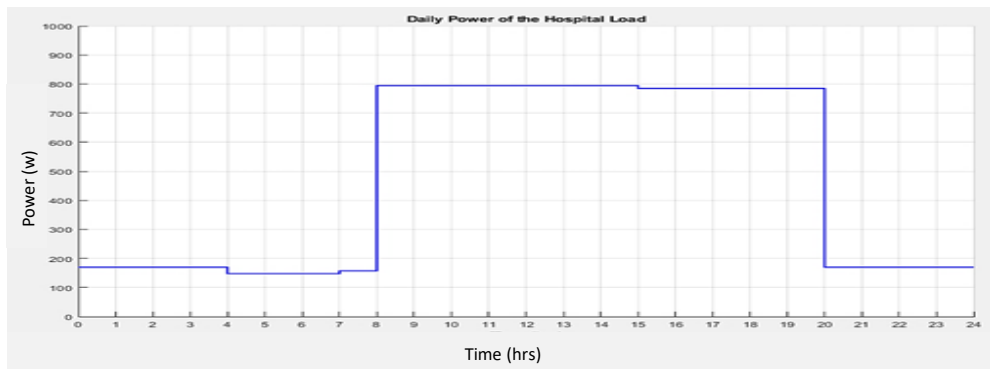

Figure 3. Daily Power of the Hospital Load.

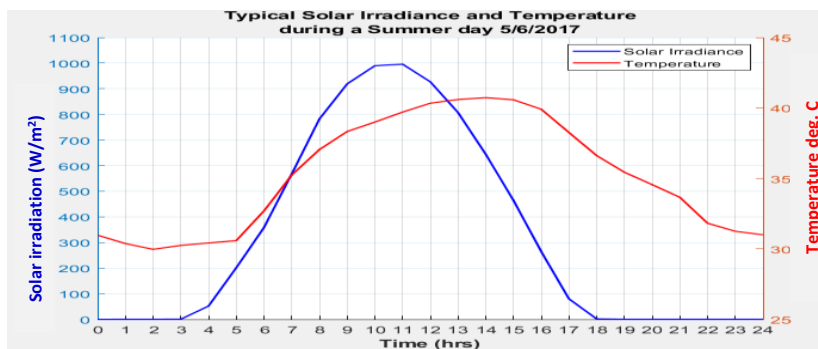

Figure 4. Solar irradiance and temperature variation during a typical summer day.

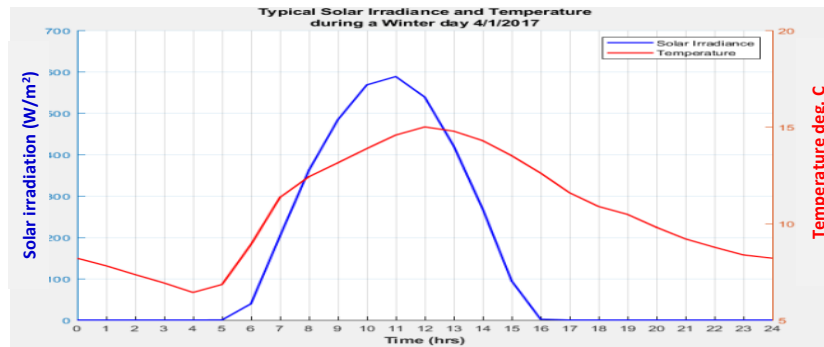

Figure 5. Solar irradiance and temperature variation during a typical winter day.

1.3 Calculations Of Daily Power Of The Hospital Load According To (SUT) Power System.

From the calculations of the load curve in Fig.3, the total load energy during the peak sun hours (from 7 am to 3 pm) was calculated to be 5721.7 kWh/day. Fifty percent of the load is supplied by the solar updraft tower (SUT) power system, while the remained load energy is supplied by another source, namely (PV), which design is out of the scope of this paper. Then only (5721.7/2 = 2860.85 kWh/day). Therefore, the power would be supplied by the (SUT) power system at nighttime. After including the (SUT) system additional load that should be supplied by SUT other than peak sun hours for the dark periods,

$$679.2 = 4 * 169.8 \text{ kWh/ day from (8 pm-12 am).}$$

$$679.2 = 4 * 169.8 \text{ kWh/ day from (12 am-4 am).}$$

$$442.2 = 3 * 147.4 \text{ kWh/day from (4 am-7 am).}$$

The total load energy during and no solar radiation from (3 pm-8 pm) was calculated to be (1962.25) kWh/ day. Fifty percent of the load is supplied by the solar updraft tower (SUT) power system. While the remaining load energy is supplied by another source, namely Batteries, its design is out of this paper's scope.

$$\text{Total} = (2860.85 + 3762.85) = 6623.7 \text{ kWh/ day.}$$

The total power generated from SUT = 6623.7 /24 = 276 kW/day. This is the power that runs the turbine, which is obtained from the hot air surrounding the turbine. Another power is added to the power of the turbine, which is 250 kW from the thermal storage (Water tubes filled with black material). It is a power that works to heat the air and rotate the turbine and works 24 hours because water is slowly gaining and losing heat. Since the heat capacity has a high (4190 kJ/ kg.k). Other heat-sensitive materials ($\Delta T_{wat} = 0 - 100 \text{ C}$) can be added and are solid materials such as sandstone or copper at the base of the collector. Or variable-phase material and this material is preferred because it has the potential energy of heat as they absorb and release a large amount of heat at a constant temperature, and are based on the phase converter principle such as paraffin wax that is placed on the floor of the collector, unfortunately. The temperature changes reach about 58°- 62° Celsius degrees, while the latent temperature has about (180- 200)10⁶J/ m³ and other materials in the solar updraft tower to improve the heat capacity. (Harte R., et al., 2013), (Talib K. Muradha, et al., 2020). The total power of the generator becomes 525kW. Divide the total power by Fifty percent, where the power of each generator is 263Kw. Two generators of power 276kW are connected because of their availability in the market to feed the required load, where simulation is performed for control on one generator to obtain the maximum power feed the required load.

1.4 Estimation of required wind turbine power rating

The energy required from the wind turbine is (6623.7kWh/ day). Following assumptions are taken into account for estimation



- Coefficient of performance (Cp) - 0.40.
- Assuming wind speed of 14 m/sec at tower base.
- Density of air inside the collector ($\rho = 1.1\text{kg/m}^3$).
- Area of turbine blade (A).
- Transmission losses (blade to generator) = 0.90 (TL)
- Generator losses = 0.90 (GL)
- Overall loss factor = $CP*TL*GL = 0.324$.

The power density of wind (power per unit area).

$$P/A = 0.5v^3\rho \tag{1}$$

1509.2Wh/m² and actual power density multiply overall loss factor equal to 488.9Wh/m². The actual power density will be converted to useful energy.

The daily energy density (useful) = power density* the number of hours per day is 11733.6Wh/m², the rotor size, and turbine power rating estimation:

Total daily energy required/ Useful energy density is equal (6623.7kWh/day)/ (11733.6 Wh/m²) the area of the turbine blade is 564.5m². and the radius of the rotor blade is (Rb = 13m).

It also represents the radius of the tower. Each turbine's power rating was calculated (actual power density × area of the rotor) is equal to 276 kW rated power wind turbine will provide the desired daily energy under the given situation. As for our design, we will use two wind turbines with a vertical axis in the tower's neck due to the amount of electrical energy that we need to feed the required load. As the feather radius for each turbine is 13m and the turbine's diameter will be 26m. Thus, the tower diameter will be about 52m plus insulator area where the turbines are placed at its base and between them. Triangle-shaped insulator for easy airflow and varying pressures assumed is a 2m. The tower at the neck is divided into two halves due to the insulator. Each half represents the diameter of the turbine. The dimensions of our design, solar updraft tower, are written in **Table 1**. The calculations for (SUT) equations are given in (Schlaich, J., et al.,1995), (Bashaer A. Kareem Hamood and Mohammed A. Nima, 2020).

Table.1 The current design solar updraft tower.

Properties	Dimensions
collector diameter	268m
Tower diameter	52m+area of insulator between the turbines assumed is a 2m
Tower height	148.8m
Collector height	3m
Mass flow rate	35251.5kg/s
Air temperature rise assumed inside the collector	20
Electrical power output from 2 turbines	Each generator gives about power 276 kW

2. WIND TURBINES.

The wind turbine can recover the power from wind given by the expression in Equation (2)

$$Pt = 0.5\rho\pi Rb^2v^2Cp \tag{2}$$

For a given wind turbine, this coefficient is a function of wind speed, the speed of rotation of the wind turbine (Ωt), and the pitch angle (β). Turbine efficiency is determined by how much power can be extracted by the turbine blades from the moving wind. Therefore, (Cp) is often given as a



function of the tip speed ratio (λ) by expression in equations (3, 4). Assuming the coefficient of performance in our design ($C_p = 0.40$) of a three-blade wind turbine and $R_b = 13\text{m}$ is the radius of the blade at constant pitch angle, and λ optimum (7.2).

$$p = f(\lambda, \beta) \tag{3}$$

$$\lambda = (R_b * \Omega t) / v \tag{4}$$

The rotor torque is obtained from the power received and the turbine's speed of rotation in equation 5.

$$Tt = \frac{Pt}{\Omega t} = \frac{\rho \pi R_b^2 v^3}{2 \Omega t} c_p = \frac{\rho \pi R_b^3 v^2}{2 \lambda} c_p = \frac{\rho \pi R_b^3 v^2}{2} ct \tag{5}$$

Where C_t is the coefficient of torque. The coefficients of power and torque are related by Equation 6.

$$cp(\lambda) = \lambda. ct(\lambda). \tag{6}$$

The equations above depend on the blades' design (Muyeen, S.M, et al., 2009). For the current design, the curve of coefficient torque of 276kW with λ , curve of power of 276kW with wind speed are shown in **Fig.6, a and b,**

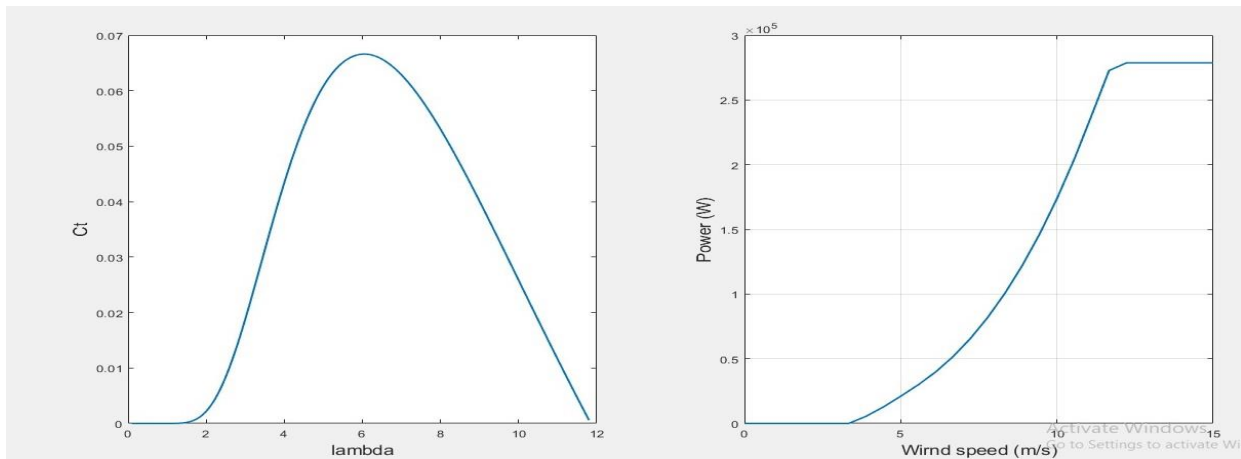

Figure.6, a and b. The curve of coefficient torque of 276kW, the curve of power of 276kW with wind speed.

The rotation speed of the wind turbine (Ωt) is associated with the mechanical speed of the shaft (Ω_m) with a gearbox ratio in Equation (7). On the other hand, the relation between the mechanical speed of the shaft (Ω_m) and the electrical speed (ω_m) rad/ s depends on the pole pairs (p) of the machine in Equation (8). Wind turbines come with different topologies, architectures, and design features (Wu, Lang, et al., 2011).

3. WIND TURBINE GENERATOR

According to many factors, the generator is chosen for the wind system, namely the produced power, rotational speed, type of electrical network, and others. The best type of generator used in wind power systems, is (DFIG) (Haitham Abu-Rub, Mariusz Malinowski, et al., 2014).

3.1 Doubly fed induction generator operation (DFIG)

The (DFIG) generator shown in Fig.7 consists of three windings to the stator connected directly to the AC- bus (grid), which is considered the main inverter output. Since the inverter is supplied from solar panels with the batteries, they are out of this paper's scope, as shown in Fig.7.

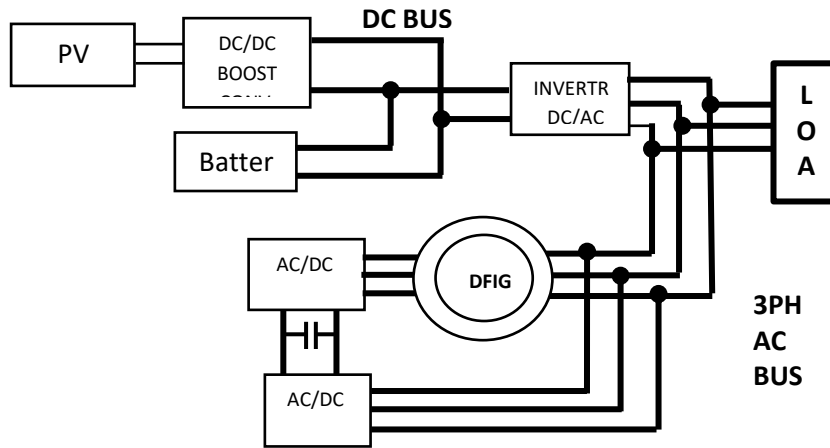

Figure7. DFIG connected directly into the AC-bus (grid).

While the rotor consists of three windings connected in an astral way, and the three ends are connected to the slip rings, which in turn and through the brushes, an external connection is reached. In recent times, this generator has been widely used in variable speed generation systems such as wind turbines and water turbines, as shown in Fig.8. This machine has many advantages, which are operation at variable rotor speed, while the amplitude and frequency of the generated voltages stay constant. The generation of electrical power under different operating conditions at (low, high) wind speeds and the control of the power factor in order to be maintained at unity. The electronics converters in variable speed wind turbines using (DFIG) usually need only to be about thirty percent of the total size of the electronics converters used to compare to sized three-phase other generators. This decreases the power electronics' cost value (Haitham Abu-Rub, Mariusz Malinowski, et al., 2014).

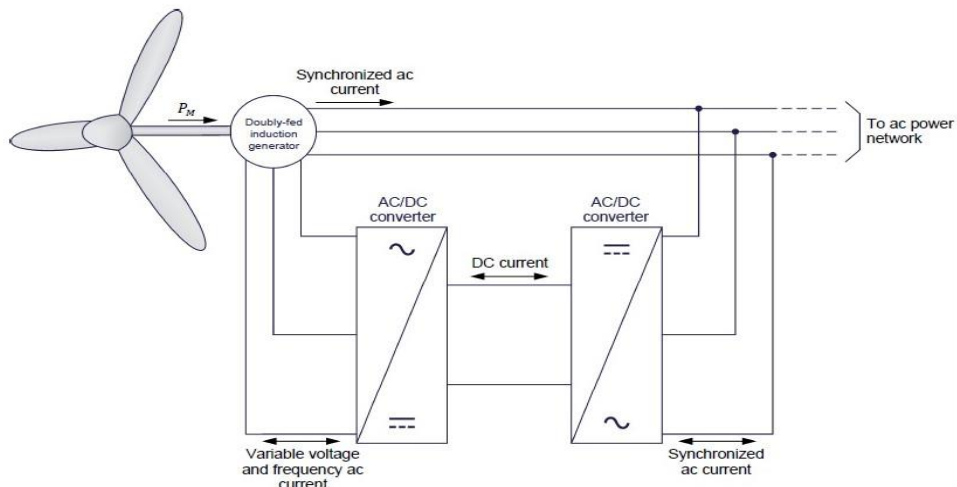

Figure8. Wind turbine with DFIG (Brahim Metidji, et al., 2012).



The relationships between the different frequencies created in the stator and rotor of the machine. Therefore, the frequency of voltages and currents generated in the stator (ω_s) is the sum of the frequency of voltages and currents generated in the rotor (ω_r) and electrical rotor speed (ω_m), as follow in Equation (7):

$$\omega_s = \omega_r + \omega_m \tag{7}$$

While the slip s of the machine is defined as:

$$S = (\omega_s - \omega_m) / \omega_r \tag{8}$$

There are three different operating modes for the machine, as explained in (Brahim Metidji, et al., 2012). Suppose (ω_m less than ω_s), the (DFIG) is operates in subsynchronous mode, the frequency (f rotor) of the ac currents increases accordingly and is of positive polarity. In that case, the DFIG receives mechanical power through its rotor that will be converted into electrical power and distributed through the stator. However, some of this power will be absorbed by the rotor windings, and the rest will be distributed to the AC-bus. And if ($\omega_m = \omega_s$) it works in synchronous mode, the frequency (f rotor) of the AC current will be equal to 0 Hz (DC). And if (ω_m more than ω_s) works in super synchronous mode the frequency (f rotor) of the ac currents increases accordingly and is of negative polarity, the DFIG receives mechanical power. Thus it is converted into electrical power and distributed to the AC-bus through the stator and the rotor windings (Brahim Metidji, et al., 2012).

3.2 Modeling of Doubly Fed Induction Generator DFIG

In electrical machines, steady-state modeling focuses on the behavior of the machine in steady-state conditions. Thus, mathematical modeling (generators equations) will be explained in (Brahim Metidji, et al., 2012).

4. TURBINE CONTROL.

According to the rotational speed, the wind turbine can operate at four different zones, as shown in Fig.6b. This paper presents the general control strategy of the wind turbine. The new wind turbine was connected to control the block to generate the torque. The MPPT of zone 2 is an operating region from (5m/s to 12m/s). The objective of speed control is to follow the path of maximum power extraction. Two different types of controllers have been considered: the electromagnetic torque reference, the electromagnetic torque related to the maximum power curve. This controller is called the indirect speed controller (ISC), which is used in this paper. The second controller is called the direct speed controller (DSC), is out of the scope of this paper (Wai Hou Lioa, et al., 2015).

4.1 Indirect Speed Controller

For any rotational speed variation around a point in the maximum power curve, the variable speed wind turbine normally goes back to its operating point is found in (Wai Hou Lioa, et al., 2015). When the turbine is working on the maximum powerpoint.

$$\lambda_{opt} = (R\Omega t) / v \tag{9}$$

$c_p = (c_p - max)$, $c_t = (c_t - opt)$, the algorithm used in this method will be used in our research. The aerodynamic torque extracted by the turbine is then given by

$$Tt = \frac{0.5\rho\pi R^3 R^2 \Omega t^2}{\lambda_{opt}^2} (c_p - max) / \lambda_{opt} \tag{10}$$

This last expression leads to the controller, as shown in Fig.9. The variation of the rotational speed Ωt , depends on the dynamics of the mechanical coupling. IN the ISC method, the electromagnetic torque T_{em} 's behavior and that of Ωt is the same (Wai Hou Lioa, et al., 2015).

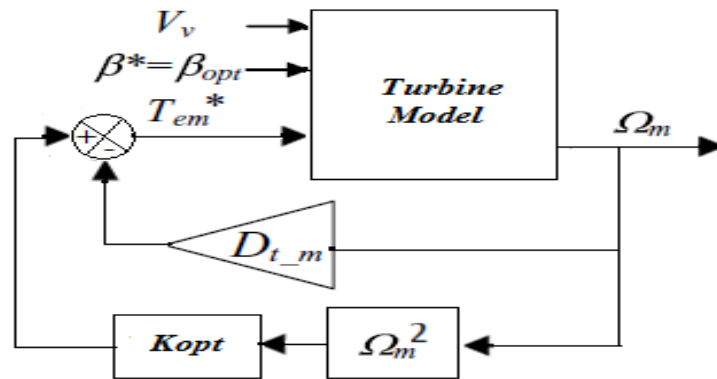

Figure9. Indirect Speed Control [Wai Hou Lioa, et al., 2015].

5. VECTOR CONTROL TECHNIQUE OF THE DFIG.

The vector control technology has spread in driving electric machines because it has many advantages, as this technology allows through an appropriate hypothesis to simplify the complex electric machine and employ simple controls in the process of driving in the case of double fed induction generator. This technology provides the ability to control rotor flux frequency, control rotor current components, and separate the process of controlling the active power from the process of controlling the reactive power. The control strategies have been performed used a stator flux space vector alignment with the d-axis for fixed frequency and voltages in the stator windings. The alignment will lead to a proportional relation between the direct rotor current and the (Q_s). The quadrature rotor current will be proportional to the torque or active stator power.

5.1 Control of the rotor side converter (RSC) (AC/DC).

It is used to maintain the constant voltage and frequency in the stator windings and obtain the maximum possible power. The (MPPT) used in the turbine was to extract the maximum power according to the appropriate wind speed, as shown in Fig.9. The rotor flux frequency is controlled according to the working speed cases (low, equal, higher). The synchronous speed, the rotor currents have been controlled.

It was then converted to voltages to generate PWM pulses according to the working condition using the PI controller's vector control method. The (RSC) will generate voltages and currents with suitable frequency. The value for rotating windings to stabilize voltages and frequency in stator windings and extract maximum power.

When the current (I_{dr}) is zero, this means that the generator is consuming reactive power (Q_s). Its value is constant, which is not controlled. Note for reference frame transformation, (θ_r) angle must be estimated, the controlling performance must be (dq) reference frame, so that the rotor voltages and currents must be transformed to (DQ) then to the synchronous rotating (dq) reference frame in (Haitham Abu-Rub, et al., 2014), (Adel Merabet, et al., 2016). In this case, The control strategies have been performed under the following assumptions; a steady-state and a stator flux space vector alignment with the d-axis for fixed frequency and voltages in the stator windings as shown in Fig.10, the active, reactive power, and torque equations must also be made dependent on the rotor currents. The equations of the DFIG model in the reference (d, q) frame and the algorithm method is obtained will be in (Haitham Abu-Rub, et al., 2014), (Adel Merabet, et al., 2016). The equivalent second-order system for both control current loops and two equal proportional-integral (PI) regulators have been chosen for both loops. They are calculated in (Haitham Abu-Rub, et al.,2014), (Ibtissam Kharchouf, et al., 2017), (Moussa Reddak, et al., 2018).

5.2 Control of Grid Side Converter (GSC) (DC/AC)

The (GSC) used to maintain DC-link voltage. 3 phase of AC-bus (grid) is linked with 3 phase GSC according to the following equations in (Pena, R., et al., 1996), (Haitham Abu-Rub, et al., 2014).

6. SIMULATION AND CONTROL RESULT OF DOUBLE FED INDUCTION GENERATOR BASED WIND TURBINE.

The double fed induction generator has been simulated and controlled by (AC/DC/AC) converter using MATLAB/ Simulink during a stable state. The control and simulation have been done for one model of 276 KW and turbine generators, as shown in Fig.10. The info on the parameters of the doubly-fed induction generator is given in Appendix A.

While the turbine is configured consistent with the generator's nominal power, the control of the DFIG is predicated on the vector control of the machine's rotor voltages by using PI control. The sampling time is (5µsecond). The (DFIG) connected to the AC- bus, which is out of the main inverter to the solar panels, batteries are connected, and the control of the main inverter is outside the scope of the paper.

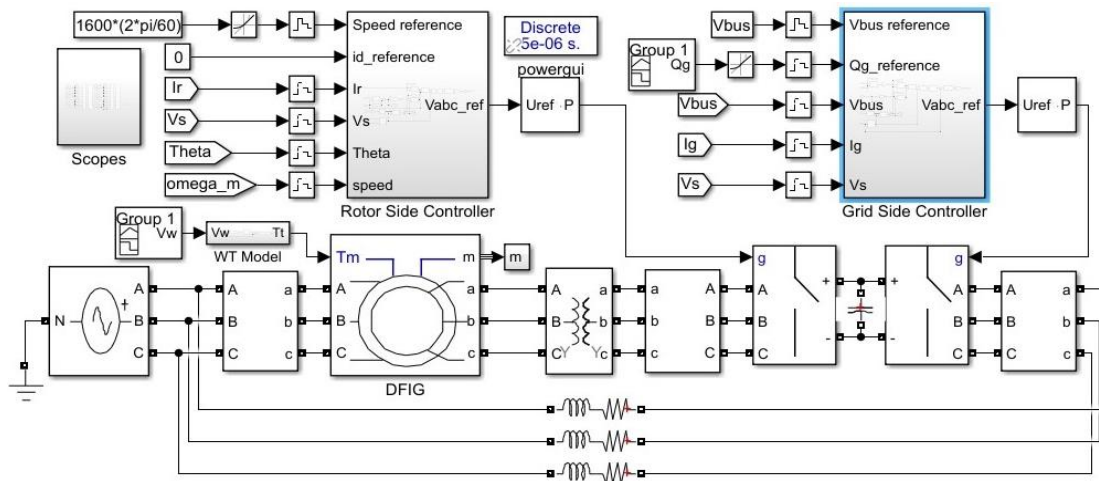

Figure 10. Schematic Diagram of DFIG Based Wind Turbine in MATLAB/Simulink.

6.1 Control of rotor side converter in MATLAB/ Simulation

The generator's rotor side (RSC) is an important part of the electrical machine. Schematic diagram of (RSC) in MATLAB/Simulink, as shown in Fig.10. It includes two movements, mechanical movement and electrical movement. Each one has its effect on the mode of the operation of the machine. As a result of its behavior and characteristic. During our work using MATLAB/ Simulink for wind energy control system employing DFIG, when operated in subsynchronous mode, synchronous mode, and super synchronous mode to get maximum power with constant magnitude and frequency of the output voltage.

The frequency of the rotor's flux is going to be controlled. The control of the DFIG is predicated by the vector control technique of the machine's rotor voltages. The PI control is performed during a (dq) synchronous reference frame rotates at ω_s , where the (d axis) is aligned to the flux of the stator space vector in (Haitham Abu-Rub, et al., 2014).

The alignment will cause a proportional relation between the direct rotor current I_{dr} and the reactive power of the stator Q_s . The quadrature rotor current I_{qr} has proportional relation with the torque or active stator power.



The control strategies have been managed under these presumptions:

- The stator windings are connected to AC- bus (grid), so the flux is constant.
- From (dq) rotor voltage equations, the rotor currents components will be controlled separately, using a simple PI controller.
- The angle (θ_r) must be calculated. The control must be carried out in a synchronous reference frame (dq), but then the voltages and the rotor's currents should be changed into (DQ) frame.
- It provides of different turns ratio that should be considered in the controlling stage. The work with the rotor's currents referred to the side of the stator. In contrast, the conversion to the rotor referred quantities has been carried out during the measurement stage for the currents and before making the pulses converted to the voltages by using (cancelation). It is provided (MPPT) in the turbine to extract the maximum power according to the appropriate wind speed. It gives the optimum electromagnetic torque, thus giving the required current (I_{qr}). In the event of a different work speed, the measured current (I_{qr}) is controlled by PI, where it corrects the error. When the current (I_{dr}) is zero according to the control strategies, this means that the generator is consuming reactive power (Q_s), it is not controlled, they are converted into voltages rotor components and then converted to (abc) to generate PWM into the converter.

6.2 Variable Speed Control by using (ISC)

In this paper, the maximum power point tracking MPPT strategy or indirect speed control will be used to get the maximum power and optimize the work of the power system. This MPPT functions on the principle of measuring and squaring the rotor's rotation speed and multiplied by (K_{opt}) constant as shown in **Fig.9**, then optimizing the required electromagnetic torque (T_{em}). The model can be simplified by neglecting the damping coefficients (Dt_m) because it is very small. **Fig.11** shows the structure of MPPT in MATLAB/Simulink. Maximum power point tracking MPPT or Indirect Speed Control (ISC) in **Fig.12**, explains the structure of the (RSC). It is controlled by measuring the rotational speed to get the required electromagnetic torque. The turbine and generator rotate at the optimum speed relating to the Equation used in the MPPT then extract the maximum power (torque) available in the wind. The generated mechanical power increases and decreases according to the wind speed value variation. With this, the robustness is confirmed of the MPPT controls strategy and how well the system responds to the wind speed variations.

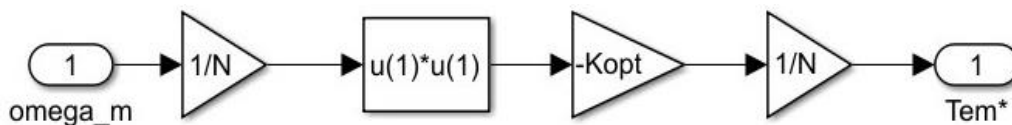

Figure11. Structure of MPPT.

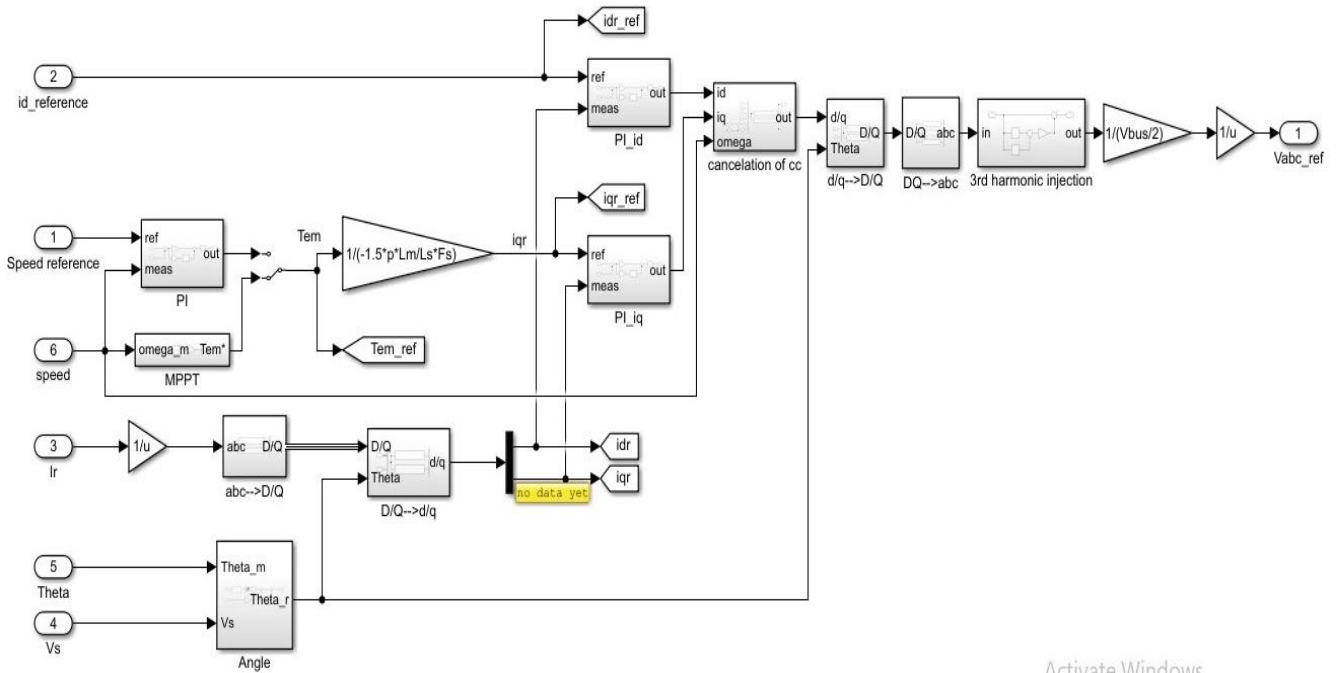

Figure 12. Block diagram of (RSC) and MPPT control strategy in MATLAB/simulation.

6.3 Control of grid-side converter in MATLAB/ Simulation

A grid side transformer (GSC) in MATLAB/Simulink is simulated and implemented. It is connected between DC-voltage and alternating voltage to manage the generator's reactive power exchange with the electrical grid (AC-bus). The main components of the grid side system are:

- The grid side converter used a perfect bidirectional switch to model the grid side converter. It must be noticed that the controlled switches ideally, not considering real characteristics like switching time or voltage drops.
- The grid side filter usually consists of inductors and resistors (LRs), which link the grid voltage and each convertor output stage. It is used to reduce high frequencies resulting from the power electronic switches.
- Work with real voltages within the (RSC) and (GSC) due to the rotor winding is (1/3) of the stator windings. Therefore an electric transformer must be installed respectively with the (RSC) and connected with the generator rotor.
- (abc) Voltages have been measured and transformed from three phases to two phases in the (dq) reference frame.
- The DC bus (Vbus) voltage has been measured and compared to the DC bus voltage reference (Vbus), the PI controller, where it corrects the error.

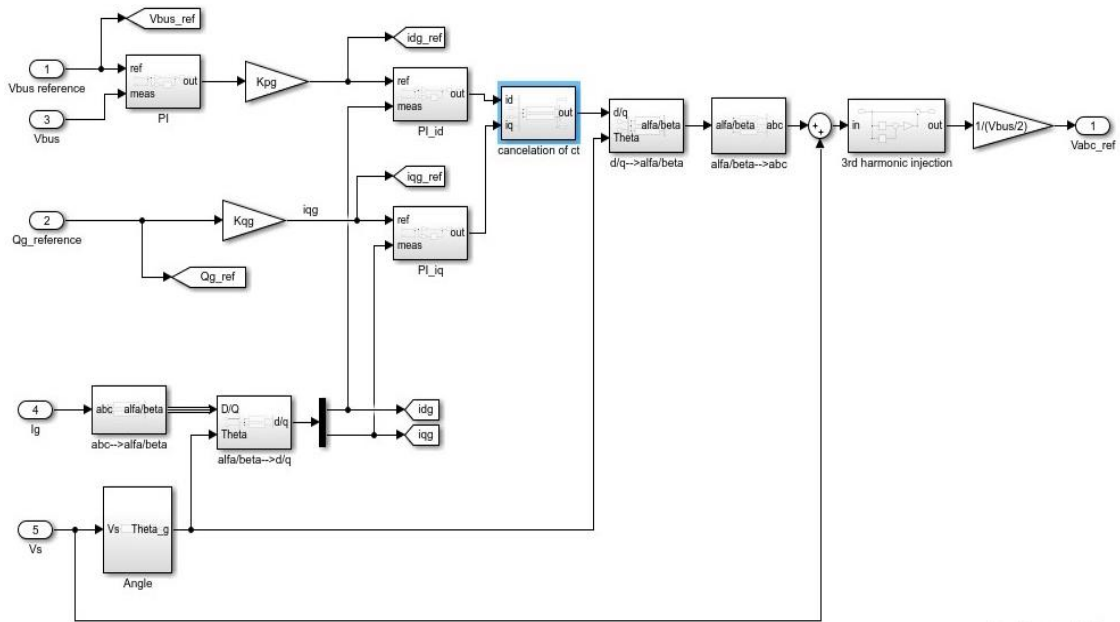

Figure 13. Control Block Diagram of (GSC).

Block control loops of dq axis current scheme has been described in **Fig.13** PI controller are used. During this diagram, the control shows the compensation terms and dq axis decoupling and thus will be formed PWM. The reference dq axis currents I_{gd} and I_{gq} are respectively provided from the block of the DC bus voltage control and reactive power control at the connection point of the GSC to the grid. The I_{gq} current has been employed to control the reactive power at the connection point of the GSC with the AC-bus (grid), while I_{gd} current has been employed to regulate the DC bus voltage.

6.4 Simulation results of the rotor side converter (RSC)

The rotor side converter results are shown in **Fig.14** a, d, and g. Where a- the rotational speed of the rotor (speed), d- quadrature current of the rotor (I_{qr}), g- direct voltage of the rotor (v_{dr}). Fig.15, b, e, and h, where b- the electromagnetic torque, e- direct current of the rotor (I_{dr}), h- quadrature voltage of the rotor (v_{qr}). Fig.16 c, f and I. Where c- stator voltage (V_s and $f = 50\text{Hz}$), f- stator current (I_s), I- rotor current (I_r).

In the first period between (1- 1.7) second, the wind speed is very low, so the wind turbines cannot be connected to the electrical power system. In this case, it will operate as a motor, and the current I_{qr} will be negative since the rotor will provide the current (the energy source will work as a motor). So the current I_{dr} suffers from some fluctuations. The torque will be positive, and its shape is the same as the current I_{qr} , according to the control algorithm and the relationship of torque to the current I_{qr} . In the second period of work, from (1.7-5) seconds, the wind system starts generating electrical power at a rotational speed below the synchronous speed.

The rotor begins to draw a current I_{qr} , considering the other current I_{dr} required is zero. The current I_{qr} is positive (because the rotor compensates for the reduced speed and its frequency). The current I_{dr} and voltage V_{dr} remain non-existent. In this period, the frequency increased the rotor's flux, and I_{qr} will be increased. The PI controller will compare the drawn current I_{qr} and the required current that depends on the electromagnetic torque. The (MPPT) presented from the control to the turbine to generate maximum power according to the wind speed, and the PI will do an error correction between them. Thus, it will affect the rotational speed. The powers will pass from GSC to RSC. In order the RSC to supply currents and voltages with appropriate value and frequency. They are injected into the rotor windings, the current I_r , as shown in **Fig.16, I**. To fix



the voltages and frequency in the stator windings, the current is changed according to the working condition because it is generated inside the stator due to induction by the rotor

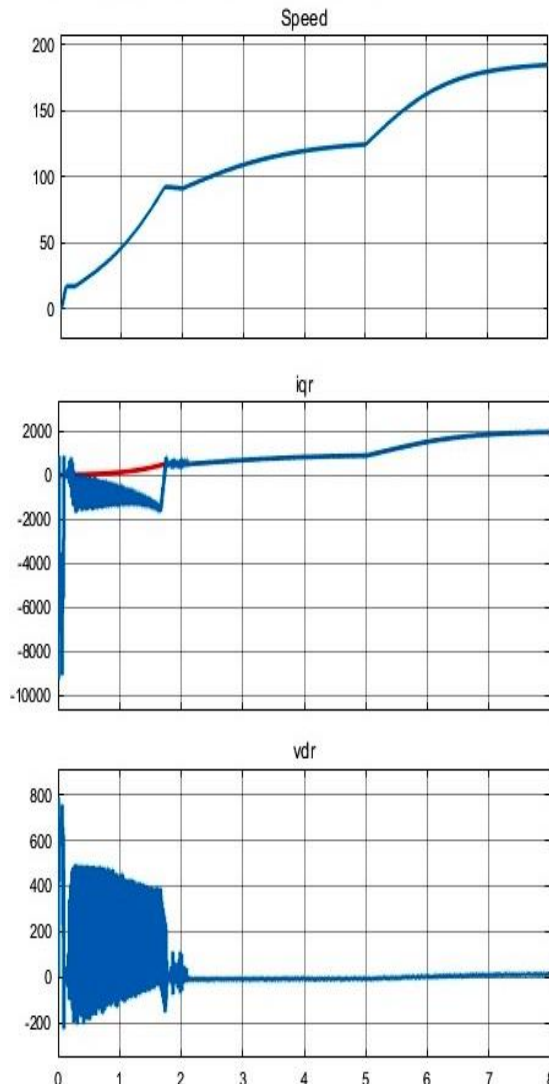

Figure 14.a, d, g, Simulation result of the (RSC).

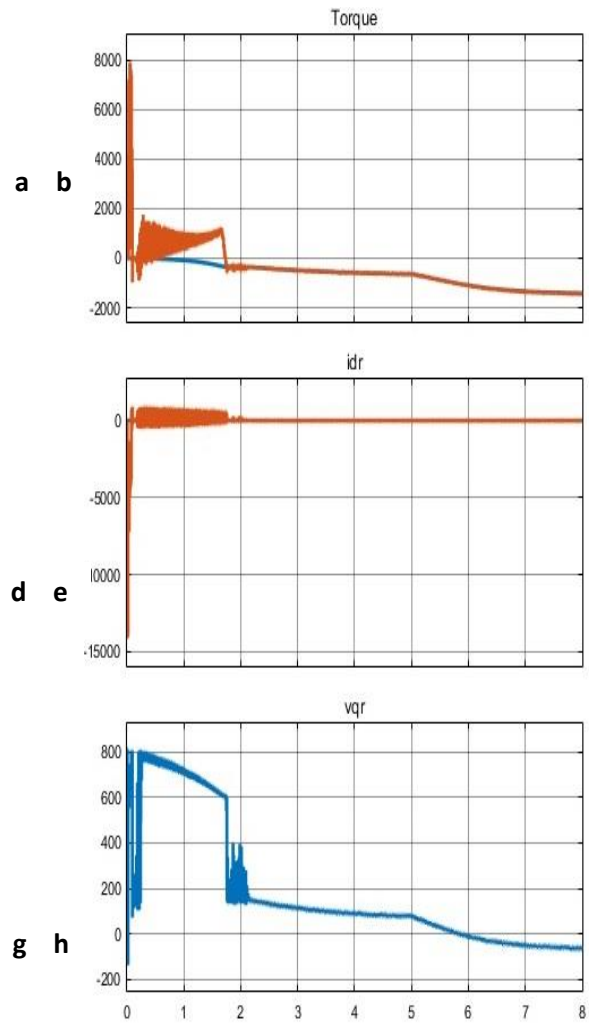

Figure15.b, e, h, Simulation result of the (RSC).

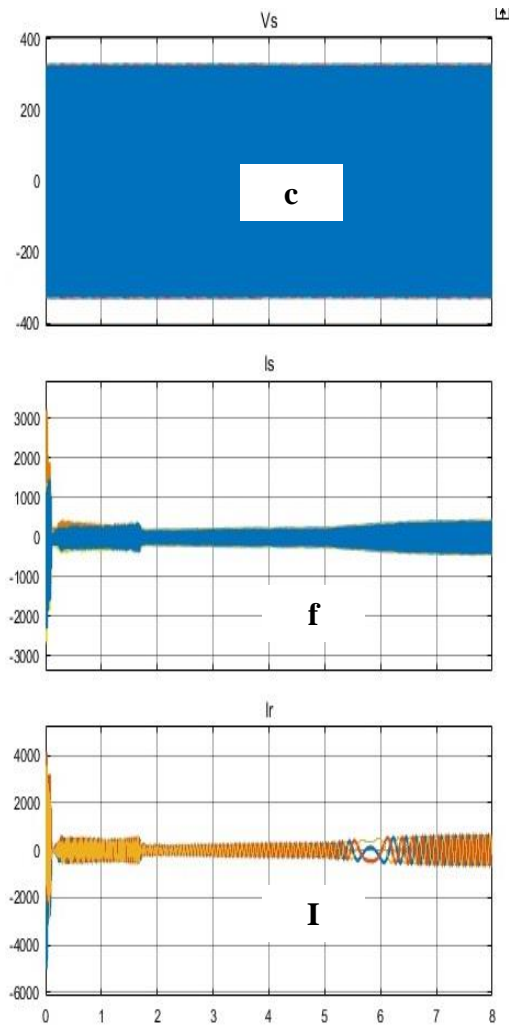

Figure16. c, f, I, Simulation result of the (RSC).

As for the third period, a gradual change in speed appears until it reaches the synchronous speed. In this period, the rotor current I_{qr} is fixed at a certain value, and this can be seen in the waveform of the rotor current I_r . In this period, the rotor flux frequency will not change, then the rotor current will be dc and the negative change of the torque will be the same as the change of the current I_{qr} , and the operation stays in generator mode. The rotor voltage V_{qr} will change in the same shape as their current I_{qr} depending on the control algorithm and with a signal that fits their relationship's nature. As for the period above of the synchronous speed, the rotor current I_{qr} will increase continuously, where this can also be observed in the form of a rotor current wave I_r when the sequences are reversed.

The torque change remains with the same change in the rotor current I_{qr} and remains negative. The other rotor current I_{dr} and voltage V_{dr} are almost zero in all periods. The rotor's flux frequency will increase in the negative direction. Then the power will flow inversely from the RSC to the GSC where the value of the DC voltage is established after, which the GSC will have sufficient value to form the power produced, which is the excess power of the rotor's work. In addition to the power of the stator in order to fix the voltages and frequency in the stator windings. Note the Negative values of the power means the DFIG supplies the power while positive values indicate that the power is consumed by the DFIG.



6.5 Simulation results of the grid side converter (GSC)

The Simulation results of the grid side converter are shown in **Fig.17 a, c, f**. Where a- the V-bus c-the direct current of the grid (I_{dg}), f- the grid's direct voltage (V_{dg}). **Fig.18 b, d, g**. Where b- the reactive power of the grid (Q_g), d- the quadrature current of the grid (I_{qg}) g-the quadrature voltage of grid (V_{qg}). **Fig.19 e, h**, where e- the current of the grid (I_g), h- the active output power (P_{out}).

Returning to the simulation model in MATLAB and also according to the working condition, the first period where the speed is very low so that the wind turbine is not connected to the electrical power system. So, in this case, it will work as a motor where the grid current I_{gd} positive because the grid (AC bus) is feeding the motor and the voltage V_{gd} is negative due to the zero reactive power. The grid current I_{gq} and voltage V_{gq} are zero because the required reactive power is zero. The current I_g will feed the DFIM in this period. In the second period, the wind turbine system generates electrical energy at a rotational speed lower than the synchronous speed. In this case, the current I_{gd} will be pulled from the grid by the generator due to the reactive and active powers passes toward the rotor. The voltage V_{gd} it is positive at the required reactive power. Also, the other current I_{gq} changes according to the change of the reactive power required. V_{gq} also depends on the required reactive power Q_g .

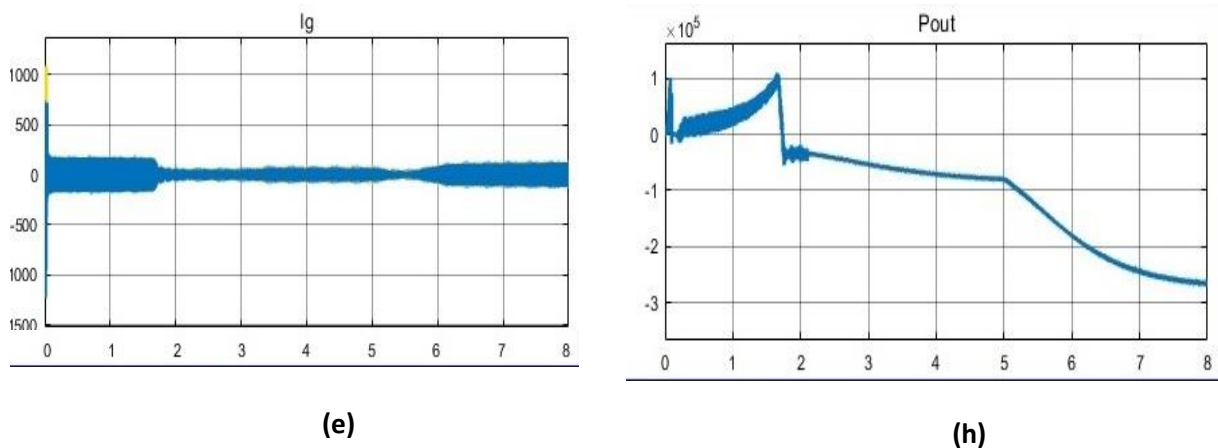

Figure 17, e, h. Controlled of AC-bus (Grid side convertor).

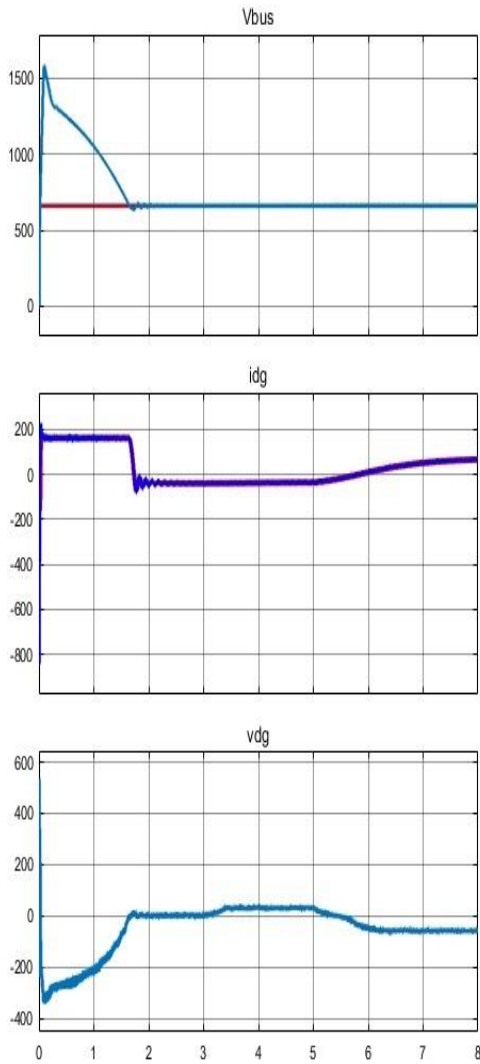

Figure 18, a, c, f. Controlled of AC-bus (Grid side convertor).

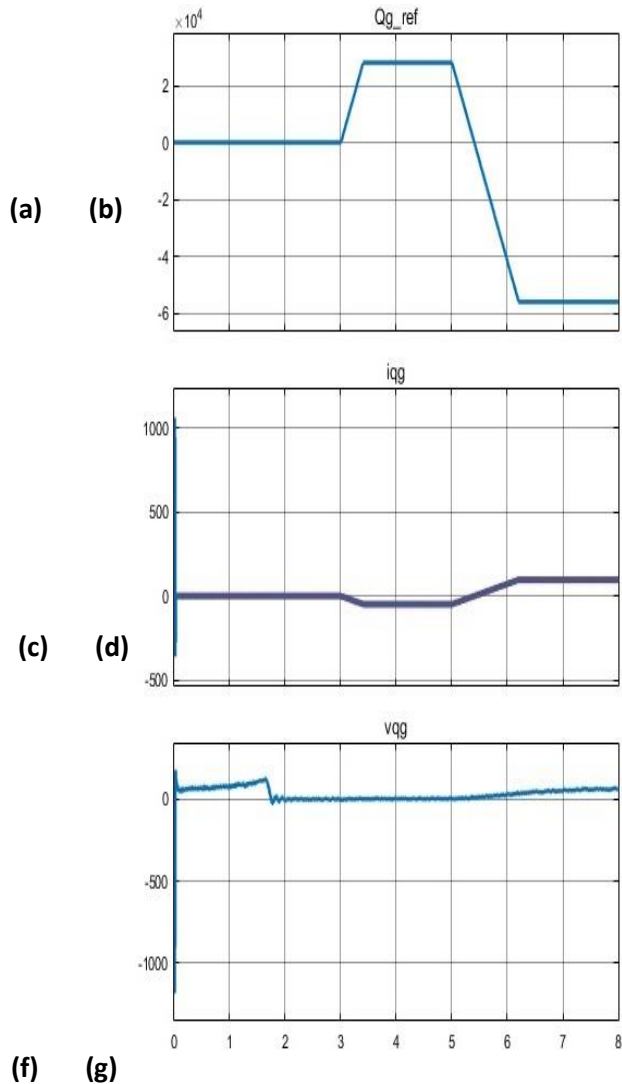

Figure 19, b, d, g. Controlled of AC-bus (Grid side convertor).

The current I_g changes according to the working condition. A gradual change will begin until we arrive at the synchronous speed. The voltages and currents will maintain a certain value. As for reaching a higher speed than the synchronous speed, the GSC provides power to the AC-bus (grid), where we note that the current I_g will be changed according to the working condition. The power generation from RSC to the GSC) and that the voltages V_{gd} , V_{gq} be variable at required reactive power, while the other current I_{gq} is like the current I_{gd} depending on the required reactive power. The current I_{gd} is responsible for controlling the voltage DC bus, and the current I_{gq} is responsible for controlling the reactive power. Not the reactive power is valued on demand.

7. CONCLUSIONS

In this paper, the SUT is designed to drive wind turbines to produce electrical power from the DFIG. The proposed controller for the DFIG is based on the stator flux vector control using PI controller to generate the pules to the RSC, GSC. Enhanced performance observed from the controller with respect to the currents, voltages, and frequencies of the rotor. The stator and AC-bus (grid) in all periods when the rotational speed is less, equal, or higher than the synchronous



speed shown in the simulation results. It was also observed the quality of the controller with respect to fast response, minimum overshoot, higher stability, and minimum rise time. The controller provided (MPPT) to the turbine generates maximum power according to the available wind speed. The control output results confirmed on maintains 98% both of the magnitude and frequency of the output voltage stays constant at the normal values and stabilization irrespective of the wind speed variation and extract maximum active power.

8. REFERENCES

- Abad, G., López, J., Rodríguez, M.A. et al., 2011. Doubly Fed Induction Machine: Modeling and Control for Wind Energy Generation, John Wiley & Sons, Inc..
- Adel Merabet, et al., 2016. Energy Management and Control System for Laboratory Scale Micro-grid based Wind-PV-Battery. IEEE transactions on sustainable energy.
- A. Ahmed, R. Li, M. Sol, and P. Joung-Hu, 2013. A Fast PV Power Tracking Control Algorithm With Reduced Power Mode, IEEE Transactions on Energy Conversion, vol. 28, pp. 565-575, Sept.
- Brahim Metidji, et al., 2012. Low-cost direct torque control algorithm for induction motor without AC phase current sensors, IEEE transactions on power electronics, volume 27, pages 4132-4139.
- Bashaer A. Kareem Hamood, and Mohammed A. Nima, 2020. Experimental Investigation of Thermal Performance of a Solar Chimney Provided with a Porous Absorber Plate, Journal of Engineering, Number 4 Volume 26 April.
- F. Denantes and E. Bilgen, et al., 2006. Counter-rotating turbines for solar chimney power plants, Renewable Energy, vol. 31, no 12, p. 1873-1891.
- Haitham Abu-Rub, Mariusz Malinowski, Kamal Al-Haddad, 2014. Power Electronics For Renewable Energy Systems, Transportation and Industrial Applications. A co-publication of IEEE Press and John Wiley & Sons Ltd, ISBN: 978-1-118-63403-5 (cloth).
- Ibtissam Kharchouf, Ahmed Essadki, Tamou Nasser, 2017. Wind System Based on a Doubly Fed Induction Generator: Contribution to the Study of Electrical Energy Quality and Continuity of Service in the Voltage Dips Event, International Journal of Renewable Energy Research, vol.7, No.4.
- J.Schlaich, et al., 1995. The solar chimney: Transferability of results from the Manzanares solar chimney plant to large scale plants, Tech.Rep., Schlaich Bergermann und Partner CEs.
- Li, H., and Chen, Z., 2008. Design optimization and evaluation of different wind generator systems. Wuhan, China. International Conference on Electrical Machines and Systems (ICEMS), 2396-2401.ttgart.
- Madawala, et al., 2012. Modeling, and analysis of a novel variable-speed cage induction generator. IEEE Transactions on Industrial Electronics, 59(2), 1020-1028.
- Moussa Reddak, et al., 2018. An Improved Control Strategy using RSC of the Wind Turbine Based on DFIG for Grid Harmonic Currents Mitigation, International Journal of Renewable Energy Research, Vol.18, No.1, March.
- Pena, R., et al., 1996. Doubly fed induction generator using back-to-back PWM converters and its application to variable-speed wind energy generation. IEEE Proceedings - Electric Power Applications, 143, 231-241.
- Schlaich, J., and Schiel, W., 2001. Solar Chimneys, Encyclopedia of Physical Science and Technology, 3rd ed., Academic Press, London.
- Talib K. Murtadha, et al., 2020. Thermal Efficiency for Passive Solar Chimney with and Without Heat Storage material", Journal of Engineering, Number 5 Volume 26 May.



- Wai Hou Lioa, et al., 2015. Fundamental performance similarities between individual pitch control strategies for wind turbines. International Journal of Control. ISSN 1366-5820, 07 September.
- Wu, B., et al., 2011. Power Conversion and Control of Wind Energy Systems, John Wiley & Sons, Inc.
- L. Whei-Min, H. Chih-Ming, and C. Chiung-Hsing, 2011. Neural-Network- Based MPPT Control of a Stand-Alone Hybrid Power Generation System, IEEE Transactions on Power Electronics, vol. 26, pp. 3571- 3581, Dec.
- F. Blaabjerg, M. Liserre, and K. Ma, 2012. Power electronics converters for wind turbine systems, 445 Hoes Lane / P.O. Box 1331, Piscataway, NJ 08855-1331, United States, pp. 708-719.
- V. C. Ganti, B. Singh, S. K. Aggarwal, and T. C. Kandpal, 2012. DFIGBased Wind Power Conversion With Grid Power Leveling for Reduced Gusts, IEEE Transactions on Sustainable Energy, vol. 3, pp. 12-20, Jan.

Appendix A

Parameters of (DFIG), Rotor parameters referred to the stator side.

Parameters	value	Name
fs	50	Stator frequency (Hz)
P	276	Rated active power (kW)
n	1500	Rated Synchronous speed
vs	400	Rated stator voltage (V)
is	360	Rated stator current (A)
Tem	1782	Rated torque (N.m)
p	2	Pole pair
u	1/3	Stator/rotor turns ratio
s	1/3	Maximum slip

Greek symbols
α, β = stationary reference frame
ρ = density of the air inside the collector ($\rho=1.1 \text{ kg/m}^3$).
ρ_0 = density of air kg/m^3
λ = lambda optimal
η_{sut} = SUT efficiency
Ω_t = speed of rotation of the turbine
Ω_m = mechanical speed of the shaft
θ_s = phase angle of the stator
θ_r = phase angle of the rotor
θ_m = phase angle of the machine
φ_{sd} = stator direct flux (wb)
φ_{sq} = stator quadrature flux (wb)
φ_{rd} = rotor direct flux (wb)
φ_{rq} = rotor quadrature flux (wb)

NOMENCLATURE			Abbreviations
	P_{mech} = mechanical power (w), P_e = Electrical power output (w)	T_t = rotor torque (N.m),	
R_{col} = Collector radius (m), H_{col} = Collector height (m)	Q_s = solar energy (w.h), V = Assuming wind speed of 14 meter/sec at tower base.	C_t = torque coefficient,	DFIG= double fed induction generator SUT=solar updraft tower.,
R_{tower} = Tower radius (m), m^0 =Mass flow rate	G = solar irradiance (w/m^2), A = Area of turbine blade(m^2)	P_t = power of the turbine (w)	RSC= rotor side convertor, PI=proportional integral control
H_{tower} = Tower height (m), ΔT =Air temperature rise (c)	C_p = Coefficient of performance (C_p) - 0.40, T_0 =Air temperature(c)	ω_m =electrical rotor speed (rad/sec)	GSC= grid side convertor, MPPT= maximum power point tracking