

Behaviour of Fire Exposed Reinforced Concrete Rigid Beams with Restrained Ends

Mohammed Mohammed Kadhum

Assist. Prof. Dr.

E-mail : Moh_Alkaafaji@yahoo.com

Nada Mahdi Fawzi Alwaan

Assist. Prof. Dr.

E-mail : naljalawi@yahoo.com

ABSTRACT

This paper is devoted to investigate the effect of burning by fire flame on the behavior and load carrying capacity of rectangular reinforced concrete rigid beams. Reduced scale beam models (which are believed to resemble as much as possible field conditions) were suggested.

Five end restrained beam specimens were cast and tested. The specimens were subjected to fire flame temperatures ranging from (25-750) °C at age of 60 days, two temperature levels of 400°C and 750°C were chosen with exposure duration of 1.5 hour. The cast rectangular reinforced concrete beam (2250×375×375 mm) (length× width× height respectively) were subjected to fire.

Results indicate remarkable reduction in the ultrasonic pulse velocity and rebound number of the rigid beams after cooled in water were (2-5 %) more than rigid beam specimens cooled in air.

Load-deflection curves indicate deleterious response to the fire exposure. Also, it was noticed that the maximum crack width increases with increasing fire temperature.

Keywords: Rigid Beams; Fire Flame; Fire Endurance; Crack Pattern; Moment Capacity

سلوك الاعتاب الخرسانية الجاسئة والمقيدة النهايات تحت تأثير لهب النار المباشر

د. ندى مهدي فوزي علوان

استاذ مساعد

جامعة بغداد / كلية الهندسة / قسم الهندسة المدنية

د. محمد منصور كاظم

استاذ مساعد

جامعة بابل / كلية الهندسة / قسم الهندسة المدنية

الكلمات الرئيسية: الأعتاب الجاسئة، لهب النار، مقاومة الحريق، نمط الشق، تحمل العزوم

الخلاصة

ان الغرض من هذا البحث هو التحري عن سلوك وسعة التحمل القصوى للأعتاب الخرسانية المسلحة الجاسئة والمقيدة النهايات والمعرضة الى لهب النار المباشر. ان تعرض الأعتاب الى لهب النار المباشر يسبب تغيرات في سلوكها الانشائي. في هذه الدراسة تم استخدام نماذج اعتاب مصغرة يعتقد بأنها توفر ظروفًا مشابهة للظروف الطبيعية الموقعية.

تضمن الجزء العملي تهيئة وفحص خمسة أنموذجاً لأعتاب خرسانية مسلحة ومقيدة النهاية. عرضت النماذج الخرسانية المستعملة إلى لهب النار في مستويات حرارة تتراوح ما بين (25-750) درجة مئوية ثم بردت بواسطة الهواء أو الماء وجرى حرق و فحص نماذج العتبات في عمر (60) يوم ولفترة تعرض ساعة ونصف. ان ابعاد نماذج الاعتاب الخرسانية المسلحة ثابتة وهو (2250×375×375ملم).

لقد أشرت النتائج انخفاض ملحوظ في فحص الامواج فوق الصوتية و مقدار الارتداد بعد التعرض إلى لهب النار، للنماذج الخرسانية المبردة بالماء حيث كانت (2-5)% أكثر من النماذج المبردة بالهواء.

اما منحنيات الحمل_ الانحراف فقد كانت الاستجابة سلبية مع درجة التعرض للنار. كذلك يمكن ملاحظة ان عرض الشق الاقصى يزداد بزيادة درجة الحرارة للنار.

INTRODUCTION

One of the problems confronting buildings is the exposure to elevated temperatures, hence, should be provided with sufficient structural fire resistance to withstand the effect of fire, or at least give occupants time to escape before strength and, or stability failure occurs.

In structural design of buildings, in addition to the normal gravity and lateral loads, it is, in many cases necessary to design the structure to safely resist exposure to fire. However, it is usually necessary to guard against structural collapse for a given period of fire exposure **Shetty, 1988**.

RESEARCH SIGNIFICAT

There are indeed little research about temperature gradient and exposure time of concrete in direct contact with fire flames.

In order to simulate this problem to practical site conditions, reduced scale rigid beam models were cast and they were as close as possible to practical circumstances. This research is sought to cover the limited area of research about this problem. This will guide and facilitate the suggestion of rehabilitation of such members exposed to fires under loading of different degrees.

The current research proposes a reinforced concrete rigid beams model which resembles the simulation of the state of stress which the reinforced concrete rigid beams are subjected to during fire in laboratory. Simulation of real fires in laboratory using a set of methane burners which subjecting the rigid beams specimens to real fire flame.

In the present work, there is an attempt to investigate the effect of exposure of concrete to fire flame on shrinkage cracking of reinforced concrete beams and some mechanical properties of concrete.

LITERATURE REVIEW

The Effect of Fire on Reinforced Concrete Structure

In the 1986, **Khan and Royles** studied the behavior of reinforced concrete beams after subjecting them to elevated temperatures. They investigated the load-deflection relationship, cracks pattern and steel to concrete bond. Prismatic concrete beams (960× 140× 66 or 107mm) were used. 8-mm plain bars and 16mm toolbars were used to reinforce them. The specimens were heated to temperature ranges from 20-800°C at a slow rate of heating (2°C/min) for one hour exposure

duration. They found that the effect of temperature is insignificant at temperatures ranging from 100 to 200°C, but the strength decreases significantly between 350 to 500°C compared with normal ambient condition, the flexural strength characteristics weakened by 50% of the original strength.

The behavior of composite beams composed of rolled steel and concreted between flanges during a fire by conducting a fire resistance test with different cross sections and load ratios, was studied by numerical analysis **Kodaira, and et al., 2004**. The results they obtained are as follows:

1. In steel-concrete composite beams which were simply supported and to which positive bending moment was applied, deformations were downward in the early period of fire, and then the deformation rate decreased once but increased again as heating was continued, leading to the limit of fire resistance.
2. The fire resistance of steel-concrete composite beams increased when the applied bending moment ratio decreased. The fire resistance time was affected by the size of the cross-section, whether steel-concrete composite beams were connected to the reinforced concrete floor or not, as well as by the applied bending moment ratio.

A case study of cracking in a concrete building subjected to fire, with particular emphasis on the depths to which cracks penetrate the concrete was made by **Georgali and Tsakiridis, 2005**. It was found that the penetration depth is related to the temperature of the fire, and that generally the cracks extended quite deep into the concrete member. Major damage was confined to the surface near to the fire origin, but the nature of cracking and discoloration of the concrete pointed to the concrete around the reinforcement reaching 700°C. Cracks which extended more than 30mm into the depth of the structure were attributed to a short heating/cooling cycle due to the fire being extinguished.

Residual bearing capabilities of fire-exposed reinforced concrete beams were investigated by **Hsu and Lin, 2006**. The analysis method includes combining thermal and structural analyses for



assessing the residual bearing capabilities, flexural and shear capacities of reinforced concrete beams after fire exposure. The thermal analysis uses the finite difference method to model the temperature distribution of a reinforced concrete beam maintained at high temperature. The structural analysis, using the lumped method, is utilized to calculate the residual bearing capabilities, flexure and shear capacities of reinforced concrete beams after fire exposure. This novel scheme for predicting residual bearing capabilities of fire-exposed reinforced concrete beams is very promising in that it eliminates the extensive testing otherwise required when determining fire ratings for structural assemblies.

In recent years a number of notable fires have occurred during construction of concrete-framed buildings, when formwork and false work has caught fire, see Figure (1). Fortunately, even after a severe fire, reinforced concrete structures are generally capable of being repaired rather than demolished **Ingham and Tarada, 2007**.

After a fire, an appraisal is normally required as soon as the building can be safely entered and generally before the removal of debris. To ensure safety, temporary false work may be required to secure individual members and stabilize the structure as a whole.

Dong and Prasad, Accepted for publication in 2008 conducted a furnace test on three full-scale two-story, two-bay composite steel frames to understand the performance of structural frames under fire loading. The three tests differed from each other in the number of heated compartments by the furnace and in the relative location of the heated compartments. For each test, the burners were operated so as to replicate the temperature prescribed by ISO 834 standard and the loads were applied using vertical loads at the top of each column by hydraulic jacks in addition to block loads placed on each composite beam. In the first test, the burners in compartment "I" was in operation, while in the second test the burners in compartment "I" and "II" were in operation, Figure (2). In the third test, the burners in compartments "I" and "III" were in operation.

In all tests, the beams to column connections as well as the columns were protected. None of the columns in any of the three tests showed signs of local buckling. Observations on local buckling of steel

beams, cracking of concrete slabs and failure of the beam-to-column connections are presented.

The results showed that the deformation process and time to failure of a structure are highly dependent on the number of compartments that are heated and the relative location of the compartments that are subjected to fire loading.

EXPERIMENTAL WORK

Materials and Mixes

Introduction

The properties of materials used in any structure are of considerable importance (Neville, 1995, and ACI Committee 211, 1997). The properties of materials used in the current study are presented in this chapter. Standard tests according to the American Society for Testing and Materials (ASTM) and Iraqi specifications IQS were conducted to determine the properties of materials.

Materials

Tasluga-Bazian Ordinary Portland Cement (O.P.C) (ASTM Type I). This cement complied with the Iraqi specification (IQS, No.5:1984). Well-graded natural sand from Al-Akhaidher region through sieve size (9.5mm) to separate the aggregate particles of diameter greater than 9.5mm. The gravel was sieved at sieve size of (20 mm). The sand and gravel were then washed and cleaned with water several times, then it were spread out and left to dry in air, after which it were ready for use. Galvanized welded wire meshes were used throughout the test program. Deformed steel bars of diameters ($\varnothing 8$ mm) and ($\varnothing 10$ mm) were used as reinforcement.

Mix Design and Proportions

The concrete mix was designed according to American mix design method (ACI 211.1-91) specification. The proportions of the concrete mix are summarized in Table (1).

Reinforced Concrete Rigid Beam Specimens

The experimental work was carried out to decide upon the temperature range and duration of burning. It was decided to limit the maximum exposure to fire flame to about 400°C and 750°C, with duration of exposure to fire flame of 1.5 hours which cover the range of situation in the majority of elevated temperature test.

After greasing the moulds of the rigid beams specimens, reinforcement bars were held carefully in their position inside these moulds. In order to get a

Cover, small pieces of steel were placed at sides of the rigid beams reinforcement. Figure 2 shows the details of the reinforcement of rigid beam specimens.

Figure a, b and c in Figure 4 show the formwork was strike after 7 days from casting and the beams were covered with wetted hessian and polythene sheets during 7 days. The hessian sheets were wetted two times a day during the curing.

Burning of Reinforced Concrete Rigid Beams

The reinforced concrete rigid beams were burnt with direct fire flame from a net work of methane burners inside the frame. The fire flame hits the lower face of these beams. The dimensions of this burner net are (2250×2250) (length × width respectively) as shown in Figure (5). The bars of flame were intended to simulate the heating condition in an actual fire. When the target was reached, the temperature was continuously measured by digital thermometers, one of them was positioned in the bottom surface of the beam in contact with the flame, while the other was positioned at the unexposed upper surface of the beam, and by thermocouple that was inserted in the center of each beam to measure the temperature at the mid-depth (187.5 mm from the exposed or unexposed surface).

Reinforced Concrete Rigid Beams and Testing Procedure

The rigid beam specimens were tested using a load cell of maximum capacity of (150 Tons) at the age of 60 days. The load was applied using steel beam that divided the load to two equal point loads. The load was applied in small increments and the readings were taken every 3.0 kN load until failure occurs. For each increment, the load was kept constant until the required measurements were recorded.

The mid-span deflection of the beam specimens exposed to fire are resulting from loading to 25% of ultimate load before burning, loading 25% and applied fire flame, thereon, cooled by water or air then residual ultimate loading after burning was applied until failure. While, for beam specimens without burning the mid-span deflection is resulting from applied load only. Testing continued until the reinforced concrete beam shows a drop in load capacity with increasing

deformation. For the column specimens which were subjected to fire flame under loading as shown in Figure (6).

Figure 7 shows a schematic diagram for loading arrangement. The specified (target) fire temperature was reached by mounting the fire subjecting burners by a sliding arm to control the fire distance to the surface of the beam specimens, and also by monitoring the fire intensity through controlling the methane gas pressure in the burners. The temperature was measured by the digital thermometer and infrared rays thermometer continuously till reaching the specified (target) fire temperature. Then, the sliding arm and gas pressure were kept at this position along the period of burning (1.5 hour). The deflection of the rigid beams exposed to fire are resulting from loading to 25% of ultimate load before burning, loading 25% and applied fire flame, and loading after burning until failure. While, for rigid beams without burning the deflection is resulting from applied load only.

For the beam specimens which were subjected to burning by fire flame under loading, the real problem which faced this process was exposing the dial gauge of deflection measurement to elevated temperatures without spoiling it. A protection system is especially made for this purpose. This equipment consists of a thin steel cover around the dial gauge. This steel cover is surrounded by a copper pipe of 7.5mm with a spiral fashion. The surface of the spiral pipe coated with a layer of glass fibre of 10mm, which is covered by a thin aluminum sheet. To protect the moving rod of the dial gauge, it was elongated by a porcelain rod. This porcelain rod is covered with a steel tube to be fitted with the moving rod as shown in Figure 8. The performance of this equipment depends on the principle of thermal exchange. Water flows in the copper pipe with a suitable discharge that keeps the temperature of dial gauge low during exposing to fire.

RESULTS AND DISCUSSION

Non-Destructive Test Results

The ultrasonic pulse velocity (U.P.V) and surface hardness of reinforced concrete rigid beams was assessed by the "Schmidt rebound hammer" test

results are presented in Table (2). Figures (9 and 10) show the effect of exposure to fire flame on ultrasonic pulse velocity and rebound number respectively for the rigid beams before and after exposure to burning. It can be seen from the figure below that the reductions in the ultrasonic pulse velocity after exposure to fire flame were as follows:

At 400°C, the reduction in (U.P.V) was (28 and 33 %) when rigid beams were cooled by air and water respectively. Whereas, at 750°C the reduction was (52 and 54 %) when beams were cooled by air and water respectively.

The effect of burning by fire flame on rebound number is shown in Figure below, it can be seen that subjecting the reinforced concrete rigid beams surface to fire causes to decrease the rebound number significantly as follows:

At 400°C, the reduction in rebound number was (22 and 27 %) for beams which were cooled in air and water respectively. Whereas, at 750°C the reduction was (42 and 45%) for beams cooled in air and water respectively.

Effect of Burning on Load Versus Deflection Results

The load versus mid-span deflection relationship of reinforced concrete rigid beam specimens which were loaded and exposed to fire flame at the same time was measured during this process are summarized in Table(3) and presented in Figure (11). Each beam specimen was loaded to 25% of the ultimate load before burning for a period of 25 minute; then exposed to fire flame temperatures of (400°C, and 750°C) thereon, cooled by water or air and finally the residual ultimate load was applied until failure.

Deflection of these rigid beam specimens, which occurred immediately when they were loaded and subjected to fire flame, this deflection is called immediate deflection or instantaneous deflection. Deflection measurement was taken continually during the test and the rate of increase in deflection was controlled to provide warning of impending collapse of the beam specimens.

From this Figure, it can be seen that the increase in the fire temperature has a significant effect on deflection of beam specimens cooled. In addition, it can be noted that the increase in the fire temperature decreases the load carrying capacity

and increases deflection in beam specimens. This can be attributed to the fact that heating causes a reduction in beam stiffness, which is essentially due to the reduction in the modulus of elasticity of concrete and the reduction in the effective section due to cracking. These Figures reveal that the load-deflection relation of the beam specimens is almost linearly proportional for temperature exposure (400°C and 750°C).

Also, it can be indicated from the results in this Figure that the ultimate load capacity of the rigid beams is adversely influenced by the fire flame exposure and this deleterious effect decreases the ultimate load capacity by about 15-37%. Also the maximum deflection at ultimate load increases by about 30% which shows clearly reduced stiffness behavior.

It is obvious from the results that the values of residual first crack load decrease when the beams are exposed to fire flame except (RB2) which increase by (4.2%) over original first crack load. This increase can be attributed to the general stiffening of the cement gel or the increase in surface forces between gel particles due to the removal of absorbed water. Figure 12 reveals the effect of fire flame on the residual first crack load for the rigid beam specimens.

Verification of Building Codes Provisions

Several existing equations are available to predict the bending moment capacity of reinforced concrete beams. These equations are selected and used in this study for comparison with the results of the experimental work. These equations are outlined in the Table (4).

Where:

M_n = Nominal moment, kN.m

$$f_{cu} = 0.85f'_c \quad \text{eq. (1)}$$

The ultimate moment M_u (for design) is

$$M_u = \phi M_n \quad \text{and} \quad \phi = 0.9 \quad \text{eq. (2)}$$

The test results were utilized to verify the recommendations and design simplifications of the various Building Codes pertaining to bending moment capacity (M_u) design. Table (5) presents the comparison between the experimental results with (ACI and B.S) Codes. The relationship between fire temperature with residual moment capacity and ultimate moment capacity are

Illustrated in Figures (13) and (14). To utilize these equations after exposure to fire flame temperatures the relative between the values ($\mu_{test}/\mu_{calculated}$) were calculated for the rigid beam specimens.

At fire temperature (400°C), for the rigid beam specimens cooled by air, the ACI and B.S Building codes close results to predict bending moment capacity, while ACI Code gave overestimated values whereas, the B.S Code gave well predicted results of beam moment capacity cooled by water.

At fire temperature (750°C), for the beam specimens cooled by air and water, the ACI and B.S Building codes became unable to predict bending moment capacity.

From the results, it is clear that the predicted ultimate bending moment capacity obtained from (ACI and B.S) Codes provisions is greater than that obtained in the experimental work after exposure to fire flame. This can be attributed to the precracking which happens upon burning.

Fire Endurance of the Tested Rigid Beams

The aim of design for fire safety should be to limit damage due to fire. The unexposed surface of each tested beam was observed throughout (1.5 hours) fire test.

Figure (15) shows the temperature-time curves for the exposed, mid-depth and unexposed surface for the reinforced concrete beams. At the beginning, the beams are at room temperature, measured to be 25°C. The experimental results clearly indicated that the temperature near the surface to fire is higher and decreases towards the top unexposed surface. It can be seen from this Figure, that the behavior of all beams tested is similar.

Fire endurance periods are determined usually by physical tests conducted according to the provisions of (ASTM E119-01) [14]. Under this standard, the fire endurance of a member or assembly is determined by the time required to reach any of the following three end points:

- 1- The passage or propagation of flame to the unexposed surface of the test assembly;
- 2- A temperature rise of 163°C at a single point or 121°C as an average on the unexposed surface of the test assembly; and
- 3- Failure to carry the applied design load or structural collapse.

Based on the results of this work, it was noticed that the test results agreed with [14]. While, these beam specimens were subjected to fire flame temperatures of (400 and 750 °C) for (90 minutes), the fire endurance of all the beam specimens investigated was reached when the inability to carry the applied design load, then these beams were considered failed according to [14].

Crack Pattern and Mode of Failure

In the present study, the development of cracks and the time at which they appeared and propagated in the reinforced concrete rigid beam specimens were detected throughout testing to assess the behavior of the beam specimens exposed to fire flame and the control beam specimens. The cracks were marked with a blue marking pen, and then photographs were taken to the crack pattern. When the load was increased, the cracks initiated from the bottom concrete surface, propagation and can be detected at early loading stages. Flexural cracks appear initially in the constant moment region. Further, flexural cracks were formed progressively and widened as the loading increased. Scabbing occurred prior to the rigid beam failure due to the crushing of the concrete. The rigid beam specimens are failed with the typical flexural failure mode (yielding of steel followed by crushing of concrete),

The beam burnt at 400°C, the flexural cracks were wide spread along the beam outside the pure bending moment region. However inclined cracks are formed due to the presence of increasing shear stresses as the load and temperature increase. For rigid beams burnt at 750°C, additional vertical cracks appeared on the beam surface, followed by formation of diagonal cracks, the failure began outside the mid span of beam. Figure (16) shows photographs for crack patterns for the rigid beams before and after exposure to fire flame.

Fire Testing Observations For Rigid Beam Specimens

During the tests, special attention was drawn to visual observations. The followings are some of the observations that were recorded

1. During the experimental test, the beam was monitored continuously for development of surface cracks. It was observed that the surface cracks formed earlier than expected, at approximately 23 and 12 minutes during burning to temperature 400°C and 750°C



respectively. These cracks eventually led to spalling of concrete cover, when the specimens were loaded after burning.

2. After the beams were subjected to fire flame, two types of cracks developed, the first was thermal cracks appearing randomly in a honeycomb fashion all over the surface. They originated from top or bottom edges and terminated near the mid-depth of the rigid beam. The crack width was about (1.5mm). The patterns of fine cracks were consistent with the release of moisture being greater in the outer layers than in the interior resulting in differential shrinkage. The second cracks were flexural tensile cracking due to loading developed in the mid-span region.
3. These cracks were observed in rigid beam specimens during burning at about (15-24 minutes) of burning.
4. Generally, runoff water from all surfaces of beam specimens in the first few minutes was noticed. This phenomenon was observed at about 10-15 minutes and continued for approximately 9 minutes for all burning temperatures 400 and 750°C. This can be attributed to the increase in vapor pressure inside the saturated voids which causes water to escape out from the cracks on the surface generated by fire exposure.
5. As loading increased, the cracks widened and extended to join and form a triangular-shaped cracks of (125-150 mm) length and (35-45mm) width as shown in Figure 14.

CONCLUSIONS

Based on the limited number of observations made in this research the following conclusions can be drawn:

1. The ultrasonic pulse velocity tested showed a response to the effect of fire flame, the reduction in (U.P.V) was (28 and 33) % and (52 and 54) % for beams cooled in air and water at 400°C and 750°C respectively. It appears that this non-destructive test gives good predicted values for the residual strength.
2. The reduction in rebound number was (22 and 27) % and (42 and 45) % for beams

cooled in air and water at 400°C and 750°C respectively. The decrease in the rebound number with increasing in fire temperature can be attributed to the fact that fire causes damage to the surface of concrete rigid beams rather than to concrete in the core of the member.

3. It was found that the ultimate load capacity of rigid beam specimens decreases significantly when subjected to burning by fire flame.
4. In this study, it is noticed that the load-deflection relation of rigid beam specimens exposed to fire flame temperature around 750°C are more leveled indicating softer load-deflection behavior than that of the control beams. This can be attributed to the early cracks and lower modulus of elasticity.
5. The ACI and B.S Codes predict ultimate moment capacity after exposure to 750°C fire flame temperature conservatively.
6. The experimental results clearly indicate that the crack width in reinforced concrete beams that are subjected to fire flame are higher than the beams that are not burned at identical loads.

REFERENCES

- ACI 318-08, 2008**, "Building Code Requirements for Reinforced Concrete", American Concrete Institute, Detroit.
- ACI Committee 211, 1997**, "Standard Practice for Selecting Proportions for Normal, Heavyweight, and Mass Concrete (ACI 211.1-91)", American Concrete Institute, Michigan, U.S.A.
- ASTM, Test Method E119-01, 2001**, "Standard Methods of Fire test of Building Construction and Materials", American Society for Testing and Materials, West Conshohocken, PA.
- BS-8110 part 2, 1997**, "Design Curves of Concrete Strength with Temperature".
- Dong, Y. and Prasad, K., 2008**, "Thermal and Structural Response of a Two-Story, Two-Bay Composite Steel Frame under Fire Loading", Proceedings of the Combustion Institute, 8pp.

Georgali, B., Tsakiridis, P.E., 2005, "Microstructure of Fire- Damaged Concrete", Case study, Cement and Concrete Composite, pp225-259.

Hsu, H.J, and Lin,C.S, 2006, "Residual Bearing Capabilities of Fire-Exposed Reinforced Concrete Beams", International Journal of Applied Science and Engineering, Chaoyang University of Technology, ISSN 1727-239.

Ingham, J., and Tarada, F., 2007, "Turning up the Heat-Full Service Fire Safety Engineering for Concrete Structures", Durable Concrete, October, pp.27-30.

Iraqi Organization of Standards, IOS 45: 1984; for Aggregate.

Iraqi Organization of Standards, IOS 5: 1984; for Portland Cement.

Khan, M. R., and Royles, R., 1986, "Post – Heat Exposure Behavior of Reinforced Concrete Beams", Magazine of Concrete Research, Vol.38, No.135, June, pp.59-66.

Kodaira, A., Fujinaka, H., Ohashi, H. and Nishimura, T., 2004, "Fire Resistance of Composite Beams Composed of Rolled Steel Profile Concreted between Flanges", Fire Science and Technology 23(3), 192-208.

Neville, A. M., 1995, "Properties of Concrete", Longman Group, Ltd., 4th and Final Edition, 1995, pp.388.

Shetty, M. S., 1988, "Concrete Technology Theory and Practice", Third Edition, PP.361.



Figure (1): The concrete frame of a ten-storey building that was fire-damaged during construction, [Georgali and Tsakiridis, 2005].

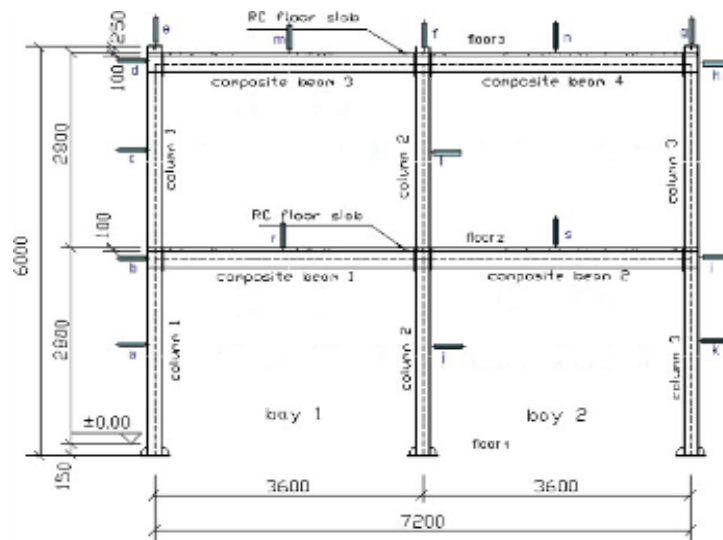

Figure (2): Elevation of the tested two-story two-bay portal frame [Hsu and Lin, 2006].

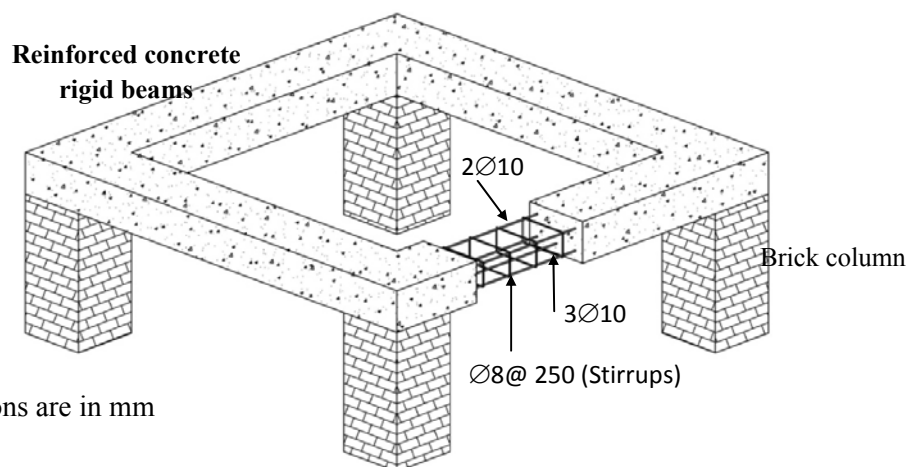

Figure (3): Details of the reinforced concrete rigid beams.



Figure (4): (A) The wood formwork of the rigid beams; (B) The rigid beams after lifting of the wood formwork; (C) Curing of Rigid beam with the wetted hessian and polythene sheets.

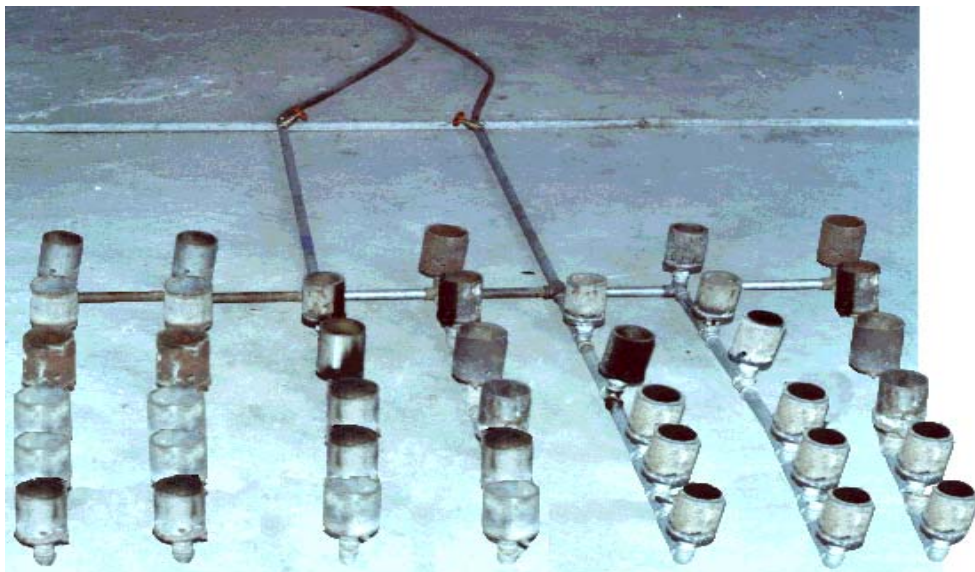

Figure (5): The work of net methane burners.



Figure (6): Testing of rigid beam specimens under 25% of ultimate load with exposure to fire flame.

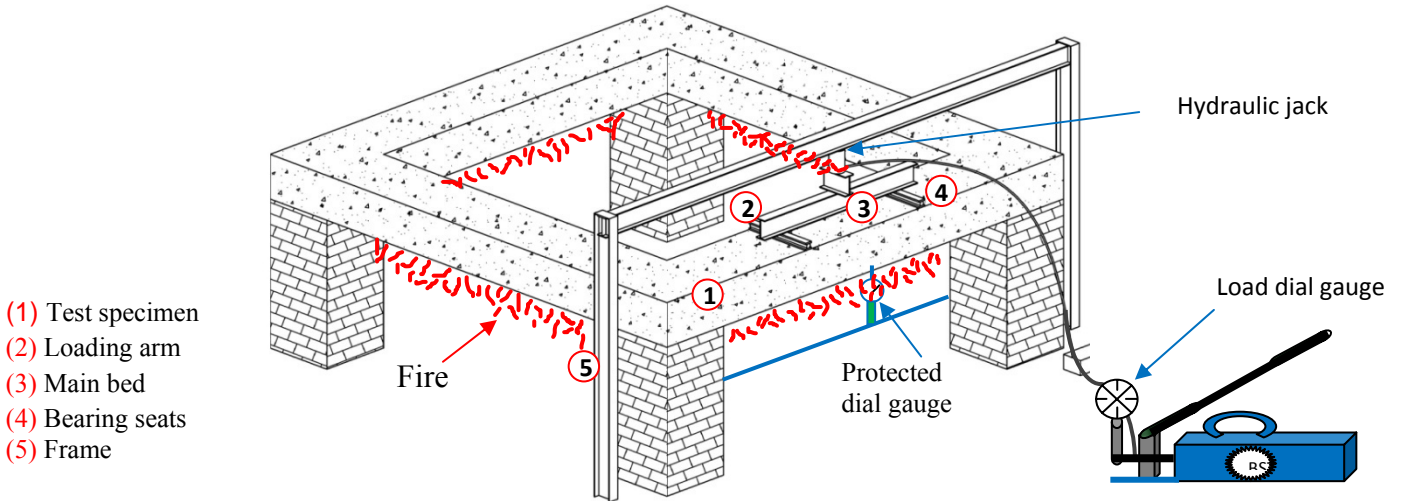

Figure (7): Schematic diagram showing the testing of beam specimens under 25% of ultimate load with exposure to fire flame.

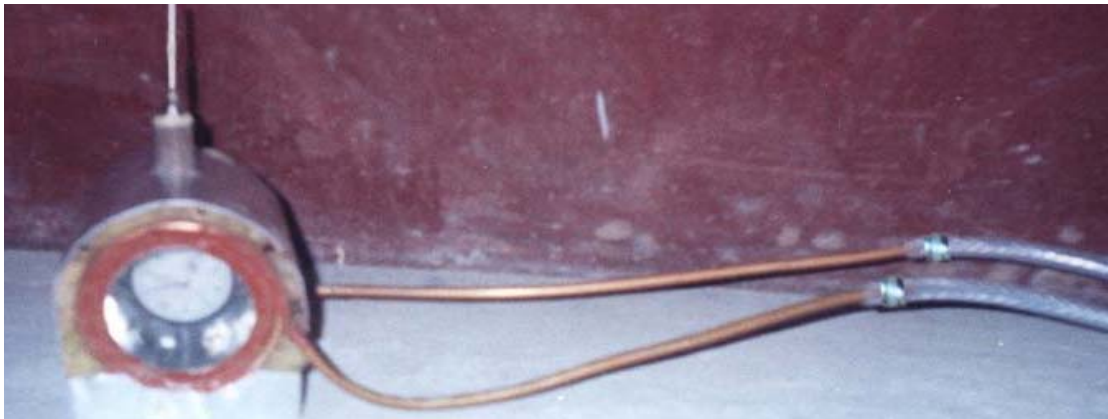

Figure (8): Protection system of the dial gauge of deflection measurement.

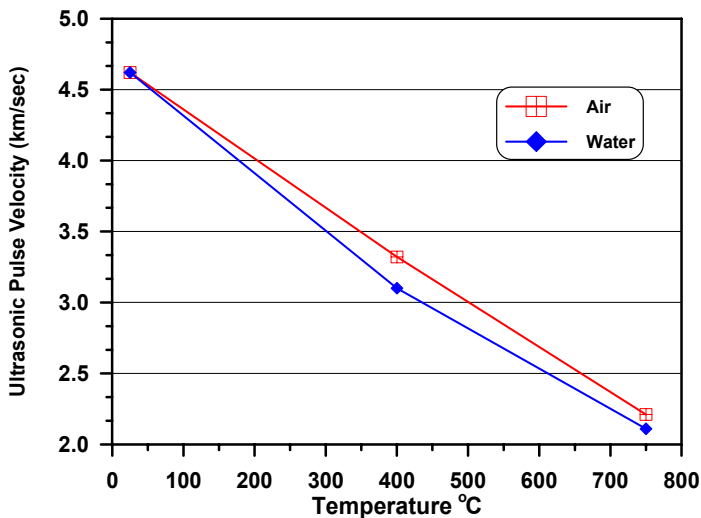

Figure (9): The effect of fire flame on the ultrasonic pulse velocity for 1.5 hour period exposure to fire flame.

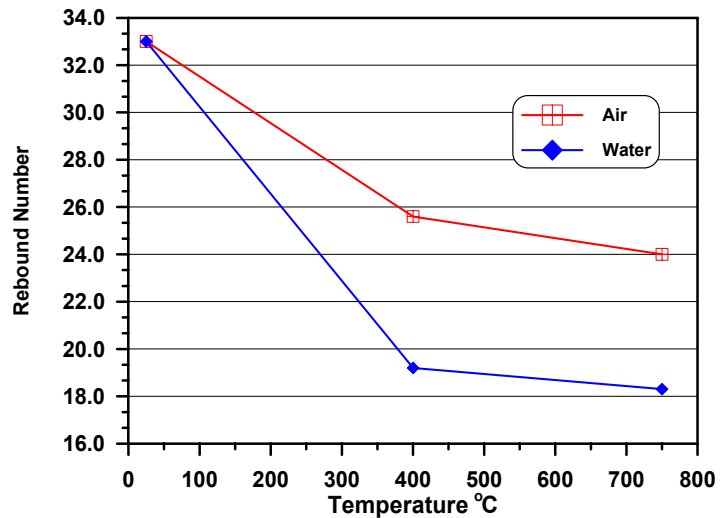

Figure (10): The effect of fire flame on the rebound number for 1.5 hour period exposure to fire flame.

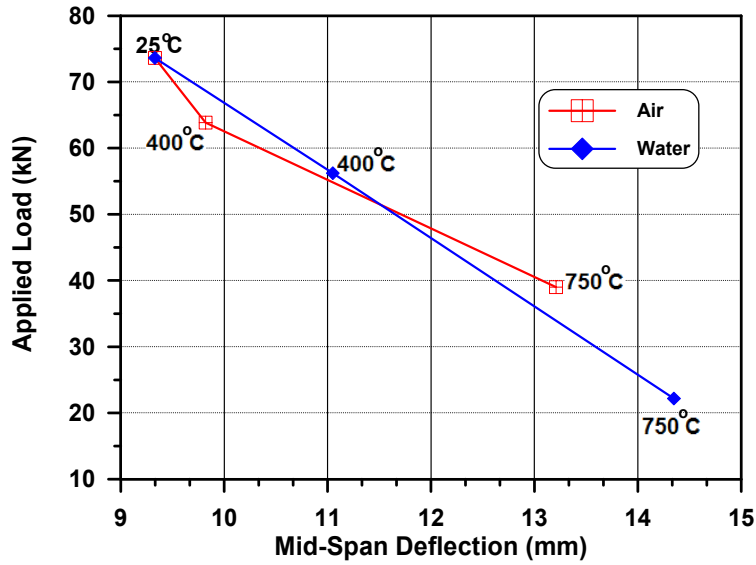

Figure (11): Load versus mid-span deflection curve of reinforced concrete rigid beam specimens.

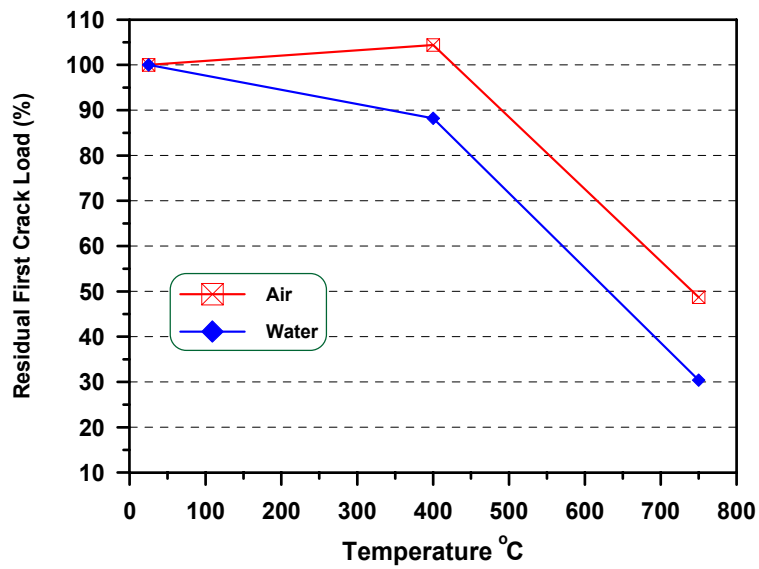

Figure (12): Effect of fire flame on the residual first crack load for the rigid beam specimens.

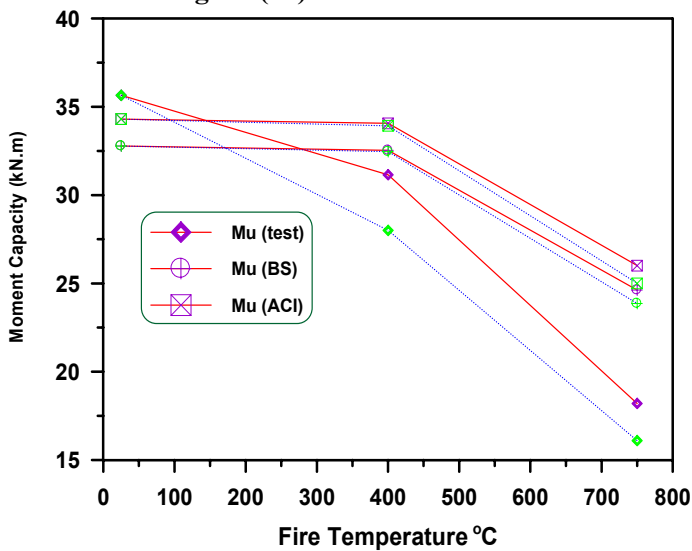

Figure (13): Effect of fire temperature on the moment capacity of beam specimens.

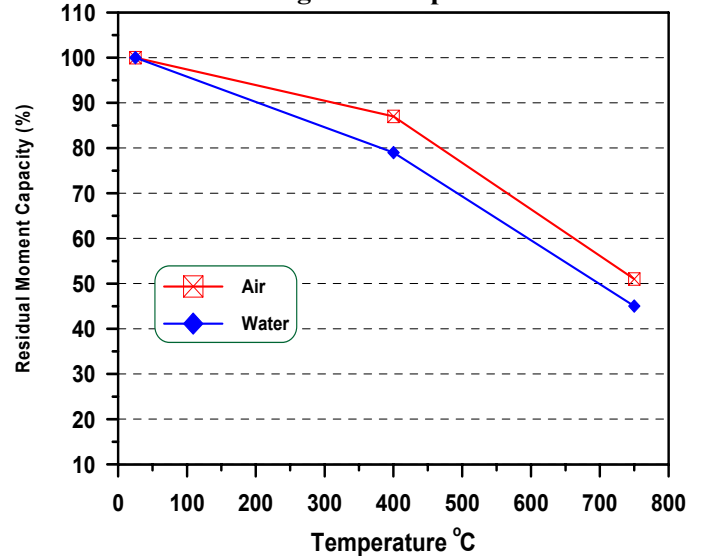

Figure (14): Effect of fire temperature on the residual moment capacity of rigid beam specimens.

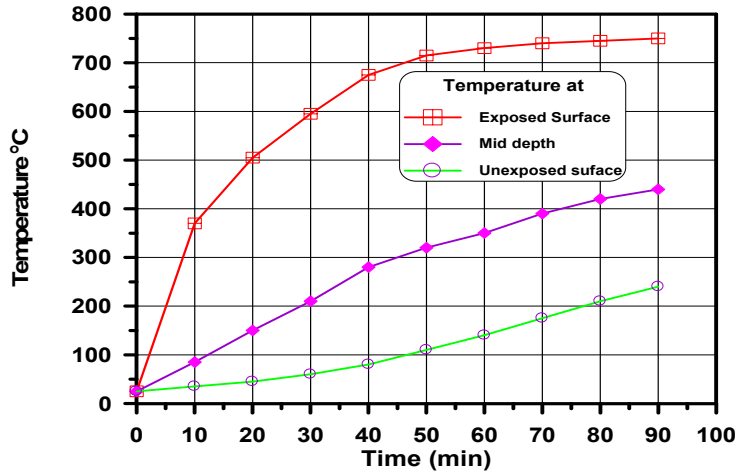

Figure (15): Effect of fire temperature on the residual moment capacity of rigid beam specimens.

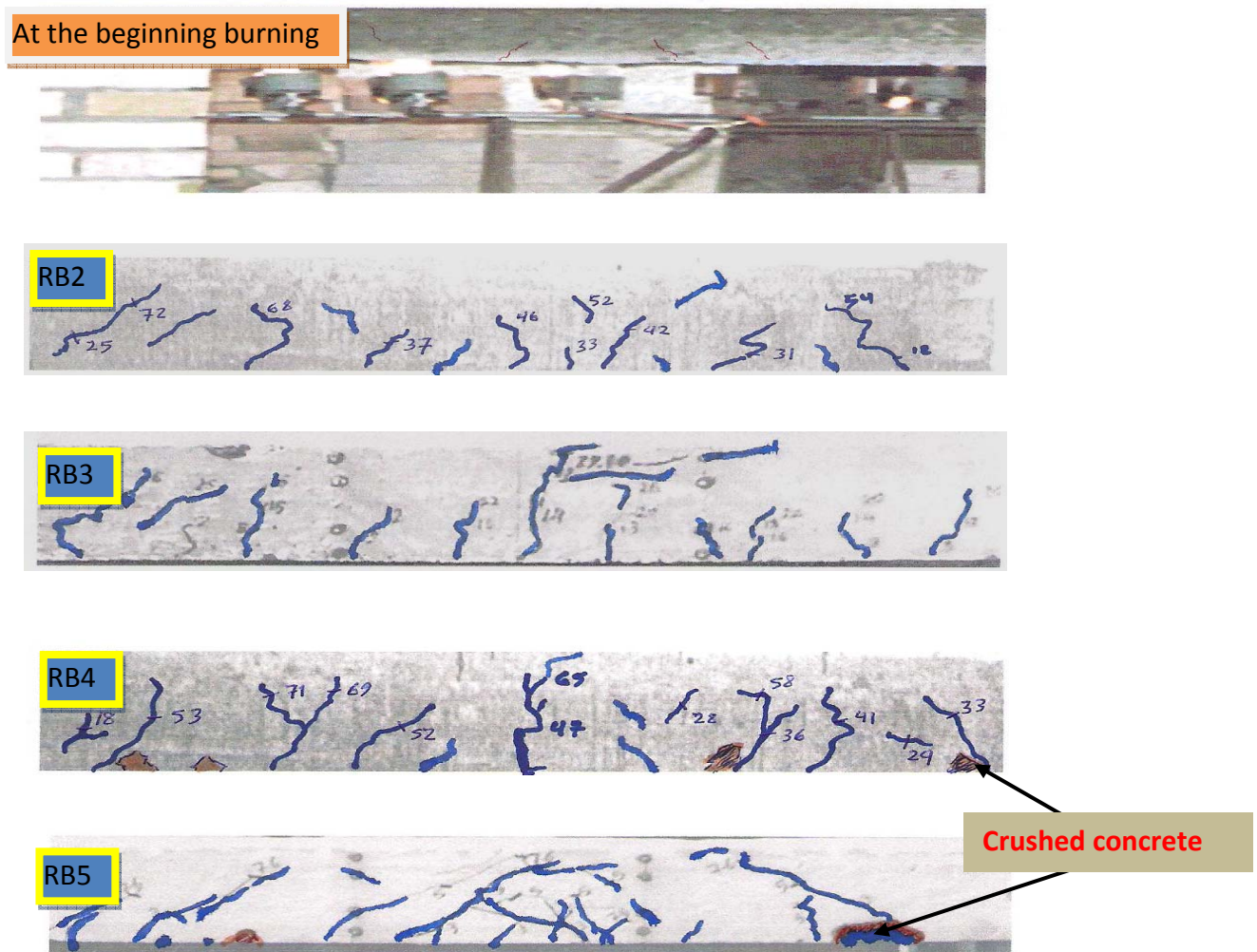

Figure (16): Typical crack pattern of rigid beam specimens before and after burning and subjected to loading.

Table (1): Mix proportions.

W/c ratio	Mix Proportion kg/m ³				Slump (mm)
	Water	Cement	Sand	Gravel	
0.45	195	435	525	1215	60

Table (2): The test results of ultrasonic pulse velocity and rebound number of reinforced concrete rigid beams before and after exposure to fire flame.

Type of Test	Temperature °C			(Va/Vb) Ratio		Type of Cooling
	25 A	400 B	750 C	B/A	C/A	
UPV (Km/Sec)	4.62	3.32	2.21	0.72	0.48	Air
		3.32	2.11	0.67	0.46	Water
Rebound Number	32	26.0	20.6	0.78	0.58	Air
		24.7	18.3	0.73	0.55	Water

Va and Vb Values of test results after and before exposure to fire flame respectively.

Table (3): Test results of the first crack load, ultimate load and deflection for control rigid beam and rigid beams exposed to burning.

Specimen Identification	First Crack Load (kN)	Percentage Residual First Crack Load %	Ultimate Load (kN)	Max Center Deflection (mm)	Type of Cooling
RB1-25°C	26.3	100	73.74	9.33	---
RB2-400°C	27.4	104.2	63.85	9.82	Air
RB3-400°C	23.2	88.2	56.22	11.05	Water
RB4-750°C	12.8	48.7	39.00	13.21	Air
RB5-750°C	8.0	30.4	22.18	14.35	Water



Table (4): Summary of formulas for predicting moment beam capacity.

Method	Equation	EQ. NO.
ACI-318M-08 Code	$M_u = \phi \rho b d^2 f_y \left(1 - 0.59 \rho \frac{f_y}{f_c} \right)$	1
B.S 8110-97 Code	$M_u = 0.87 f_y A_s \left(d - \frac{f_y A_s}{1.34 f_{cu} b} \right)$	2

Table (5): Comparison of the moment capacity test results with that obtained from (ACI and B.S) Codes for beam

Specimen Identification	Cylinder Compressive Strength (MPa)	Steel Yield Stress (GPa)	Ultimate Load (kN)	Percentage Residual Moment Capacity	M _u (kN.m)			$\frac{M_u(Test)}{M_u(BS)}$	$\frac{M_u(Test)}{M_u(ACI)}$
					Test	BS	ACI		
RB1	24.0	530	142.6	100	35.65	32.78	34.30	1.09	1.04
RB2	19.7	530	124.4	0.87	31.15	32.53	34.06	0.96	0.91
RB3	18.5	530	112.0	0.79	28.00	32.46	33.92	0.86	0.83
RB4	12.4	408	72.8	0.51	18.20	24.62	26.00	0.74	0.70
RB5	6.6	408	64.2	0.45	16.10	23.56	25.00	0.68	0.64