

## The Effect of Tool Path Strategy on Mechanical Properties of Brass (65-35) in Single Point Incremental Sheet Metal Forming (SPIF)

Dr. Qasim Mohammed Doos Al-  
Attaby

kasim\_daws@yahoo.com

Dr. Tahseen Fadhel Abaas

tfalani@yahoo.com

Aqeel Sabree Bedan

akeelsabree@yahoo.com

### ABSTRACT:

In this paper, three tool paths strategies; iso-planar, helical and adaptive have been implemented to investigate their effect on the mechanical properties of Brass 65-35 formed by single point incremental sheet metal forming process. To response this task, a fully digital integrated system from CAD modeling to finished part (CAD/CAM) for SPIF process has been developed in this paper.

The photo-micrographs shows an identical grain formation due to the plastic deformation of the incremental forming process, change in the grain shape and size was observed. It's found that the adaptive tool path play a significant role to increase the hardness of the formed specimen from (48 to 90 HV) and the grain texture of the formed specimen found as round shape, while the hardness is increased in little amount from (48 to 74 HV) in the specimen formed using helical and it's grain texture was found as needle shape.

**Keywords:** Single Point Incremental Forming (SPIF), Tool path Strategy, Microstructure, Hardness test.

### تأثير مسار العدة على الخواص الميكانيكية في التشكيل النقطي التزايدى لسبيكة البراص 35-65

عقيل صبري بدن

ا.م.د.تحسين فاضل عباس

ا.د.قاسم محمد دوس

#### الخلاصة :

تم في هذا البحث اعتماد ثلاثة طرق لمسار العدة في دراسة تأثيرها على الخواص الميكانيكية لسبيكة البراص (35-65) عند تشكيلها بطريقة التشكيل النقطي التزايدى وباستخدام نظام تصميم وتصنيع متكامل تم تطويره لانجاز هذا البحث، تبين من خلال الفحص المجهرى للعينات المنجزة بان البنية المجهرية قد تغيرت من ناحية الشكل والحجم نتيجة التشكيل اللدن من جراء التشكيل واستنتج بان مسارات العدة لها اثر كبير في تغير الخواص من ناحية الصلادة والبنية المجهرية حيث تبين بان مسار العدة المحسن (Adaptive) رفع من صلادة النماذج المشكلة (48-90) وحافظ على الشكل الدائري للبنية المجهرية للبراص في حين ان مساري العدة ( Isoplaner and Helical) قد رفعا الصلادة بمقدار اقل من الاول (48-74) بينما تغيرت البنية المجهرية للنماذج المشكلة حيث تم الحصول على بنية مجهرية طولية الشكل.

الكلمات الرئيسية:- التشكيل النقطي التزايدى، ستراجية مسار العدة، الفحص المجهرى، فحص الصلادة.

## **INTRODUCTION:**

In most manufacturing industries, prototype manufacturing is an important step in the development or improvement of a product before proceeding to the manufacture of production. It allows a preliminary evaluation of the product during the design stage, and a reduction in the product development time (Rattanachan K.2009).

Incremental sheet forming technology (ISF) using CNC machine aims to reduce the investment costs and lead-time of tooling development in sheet metal forming. This technology has been investigated to become a pre-eminence process for low (or medium) production batches and rapid prototype manufacturing.

The ISF technology is a forming approach in which uses the numerically controlled (NC) technology to produce a part from the sheet materials. With this technology, the new product can be made in short time from CAD modeling to finished part (Chezhian B.S.2012).

Single Point Incremental Sheet Metal Forming (SPIF) distinguishes itself by the use of simple tools mounted on CNC machines with the aim of permanently deforming the sheet metal in order to form the sheet metal into the desired shape, a suited tool, mounted on the machine end, is moved accordingly to a predefined path (Jeswiet J.2007).

The main advantages of SPIF are best formability of sheets - reducing costs when prototypes or batches have to be manufactured while the drawbacks manufacture's times longer - sometimes poor geometry's respect and surface aspect Different steps of this process are shown in Fig. (1).

## **DEVELOPED SYSTEM**

The developed system can recognize automatically the profile of CAD model of SPIF product. Then, it generates tool path based on machining data flow from CAD model to CNC code. For simplicity, a conical shape with varied degree forming angle along its profile as in figure(2) was formed during all the experiments of investigations, as maintained previously,

three tool paths are employed to formed three specimens.

An integration of the tool path definition created by Matlab has also been developed then the data have been transferred to the CNC to control the tool.

The system is connected to CNC interface through Ethernet. All modules were integrated fully on Matlab software. The basic elements of ISF system are illustrated in Fig.(3).

## **TOOL PATH STRATEGIES:**

The path followed by the tool is generated by CAM software, starting from the CAD model of the object. The tool deforms the sheet starting from the centre and moving towards the boundary, both outer-to-inner and inner-to-outer paths can be used.

The exact CAD model of final product is built in Matlab using Lagrange technique (Tahseen F,2011), this model is used as an input object to generate tool path. In commercial CAD/CAM system, there are two approaches for generating a tool-path that can be utilized for SIPF process, known as Iso-planar tool path and helical tool path.

In Iso-planar tool path the tool deform the sheet metals from the center and moving towards the boundary then it progress to the final depth of forming in circular movement with out changing the feed direction, The characterization of this tool path is only a continuous feed rate in X- and Y- direction of a deformed sheet plane, the feed rate in the Z-direction is done in the same angular position in the XY plane along a line down the side of the sheet (Syed A. R.2009). as illustrated in Fig.(4).

In helical tool path strategy, the tool progressively deforms the blank with a spiral movement from the top going towards the maximum depth (Hu Zhu 2011), the helical tool path gives a continuous feed in all three directions X, Y and Z depth (Fig. 5).

In this work, three tool path strategies Iso-planar , Helical and adaptive tool path was proposed and tested to investigates the effect of these tool paths on the mechanical properties of Brass 65-

35 in SPIF. In the adaptive tool path the tool is progressively moved downwards up to the bottom of the object progress in circular movement and the feed direction was changed for each successive layer, an example of tool path generated is shown to fig. (6).

### EXPERIMENTAL WORK:

The experiments were carried out (State Company for Inspection and Engineering Rehabilitation activities (S.I.E.R)) using the Brass 65-35 sheet (Iso- Cu Zn 35 426/1), whose chemical composition is given in table (1).

A series of tensile tests were performed (University of Technology /Production Eng.) in order to determine the mechanical properties of blank material, the standard dimension of tensile test specimen cut of using CNC-milling machine and tool diameter 8mm (fig.7), mechanical properties given in table(2).

The primary microstructure of the yellow Brass65-35 (C26800) blank has a structure consisting of a single phase that labeled ( $\alpha$ )(Mills Kathleen2004). Phases occupying such a position on an equilibrium diagram are solid solutions, as shown in Fig (8). Such solutions are invariably tough and ductile and this particular one is no exception, being the basis of one of the most malleable and ductile metallurgical materials in common use. Brasses containing between 10% and 35% zinc are widely used for deep drawing and general presswork.

A blank having the size of (225 mm  $\times$  225mm  $\times$  1mm) was tightly held at the periphery by a blank holder. A tool with the hemi-spherical end of 12 mm diameter shaped the part at the room temperature. The forming tool traveled along three different tool paths to formed three specimens. Fig.(3) illustrates the experimental set-up employed in this paper.

### RESULTS AND DISCUSSION:

The results of hardness tests shown in Figure(9). The adaptive tool path(M2) specimen has the highest hardness specimen in group (92 HV) and its texture found round Fig (11). The hardness of iso-planer tool path(M1) specimen was

increased to (76 HV) and it's texture found as a needle shape Fig.(10) , while the helical tool path(M3) specimen has the lowest increasing in hardness in the group (74 HV) and it's shape found as a needle shape also Fig.(12)

In adaptive tool path strategy grain-refinement occurred during the plastic deformation according to reflect the direction of the tool among the tool path in each successive deformed layer; on other hand a large amount of residual stresses within the structure due to tension and compression effect, so the hardness of the final product increased (48-92HV).

While in helical and iso planer tool path strategy the plastic deformation was occurred in one direction (isotropic) so the grains structure elongated in the direction of the tool path and this effect causing increasing the hardness of the final product (48-76HV).

### CONCLUSIONS:

In this work, Brass 65-35 sheet was incremental formed under different-Tool path strategies and their effects studies, the following conclusions were drawn from the study:

1. The tool path strategy was found to effect on both hardness and microstructure of the specimen formed by SPIF.
2. The adaptive tool path was seen to be the most effective tool path over the variation in the tool path to increase the hardness of the formed specimen along it's profile depending on the slope angle
3. The microstructure of the formed specimen using adaptive tool path are found as a round shape and this according to the variation of the tool path in the direction of the feed , while the microstructure found as a needle shape in the formed specimen formed by both isoplanar , the same observation was prevalent by using helical tool path.

## REFERENCES:

Chezian Babu S., "Effect of Process Variables during Incremental Forming of Deep Drawing Steel Sheets", European Journal of Scientific Research, ISSN 1450-216X Vol.80 No.1, pp.50-56, 2012.

Hu Zhu, "Spiral tool-path generation with constant scallop height for sheet metal CNC incremental forming", Int J Adv Manuf Technol 54:911-919, 2011.

Tahseen F. Abbas, Aqeel S. Baden, "Statistical and Visual Analysis of Error In Interpolating Sculptured Surfaces", Eng. & Tech. Journal, Vol.29, No.12, 2011.

Mills Kathleen and others, "ASM Metals handbook metallographic and microstructures", volume 9, 2004.

Rattanachan K., "Formability in Single Point Incremental Forming of Dome Geometry", AIJSTPME 2(4): 57-63, 2009.

Syed Asad Raza Gardezi, "Tool path Generation in SPIF, Single Point Incremental Forming Process", 2009.

Silvaa M.B., Skjoedtb M. "Single point incremental forming of tailored blanks produced by friction stir welding" journal of materials processing technology 2009, 811-820, 2009.

Jeswiet J., "Asymmetric Single Point Incremental Forming of Sheet Metal", Queen's University, Kingston, ON, Canada, 2007.

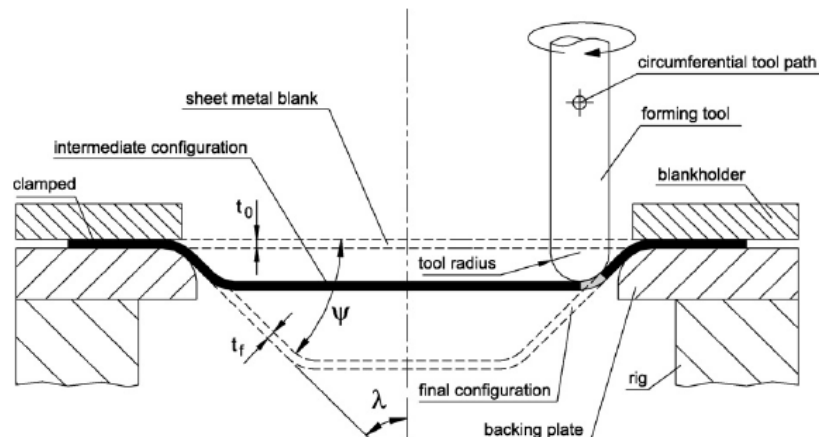

Figure (1) Single point incremental sheet metal forming process (Silvaa M.B.2009).

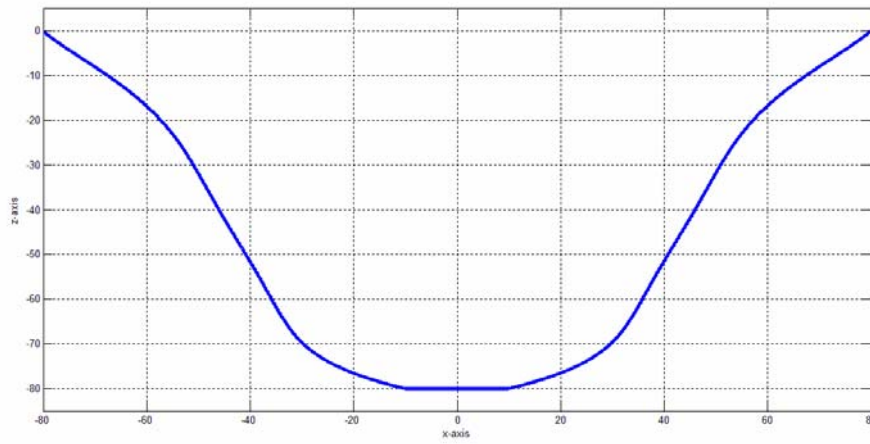

Figure (2) a conical shape profile

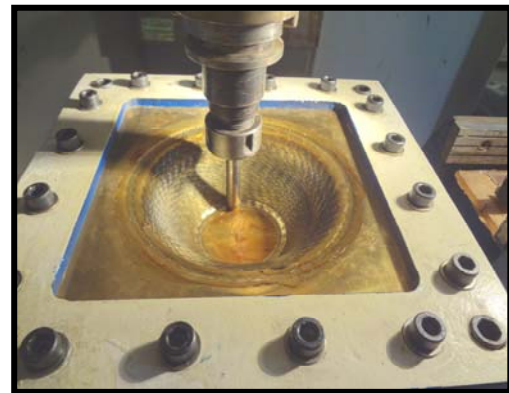

Figure (3) the experimental set-up

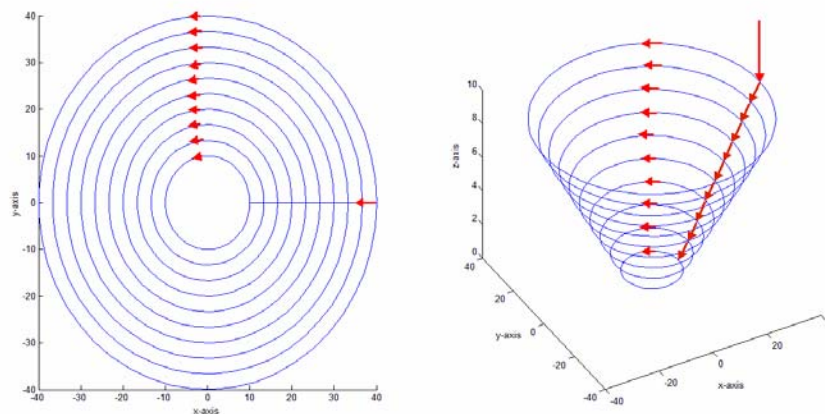

Figure (4) Isoplaner tool path.

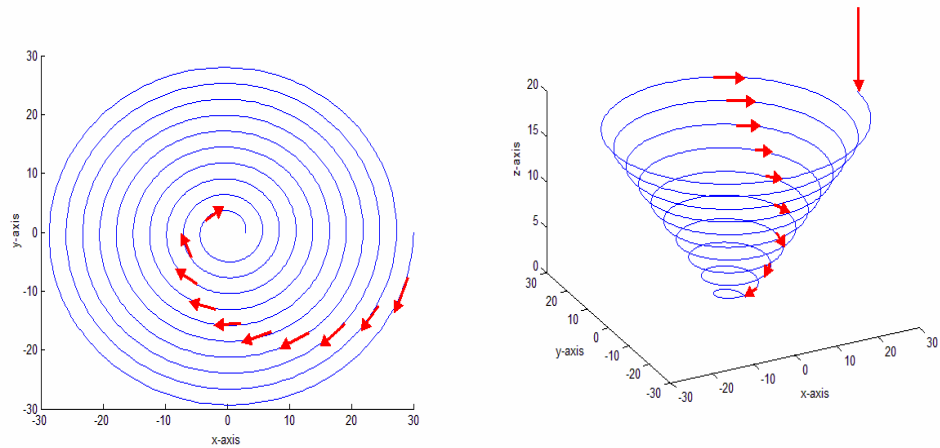

Figure (5) Helical tool path.

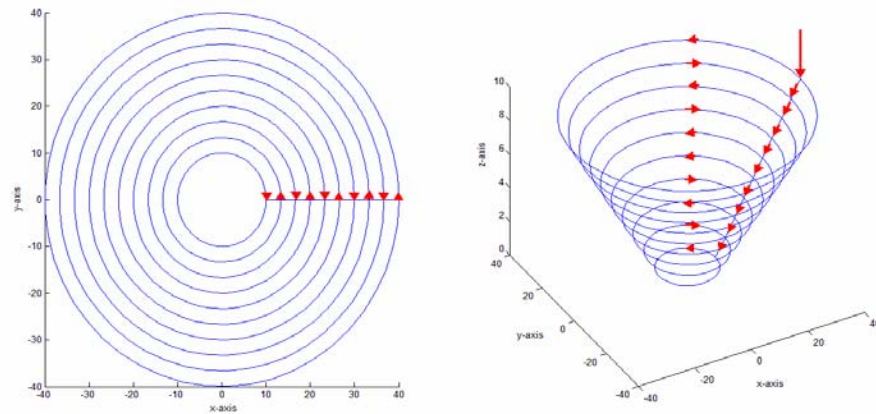

Figure (6) Adaptive tool path.

Table (1) Brass (65-35) chemical composition

Material		Zn%	Pb%	Sn%	P%	Mn%	Fe%	Ni%	Si%	Al%	Cu%
Brass	Exp.	35.23	0.007	0.001	0.007	0.000	0.021	0.001	0.001	0.002	64.7
	Iso	35.0	0.0	0.0	0.0	0.0	0.0	0.0	0.0	0.0	65.0

Table (2) Brass (65-35) mechanical properties of blank material

Material		Tensile Strength MPa	Modulus of Elasticity GPa	Poissons Ratio	Elongation % on 50 mm G.L.	Vickers Hardness HV	Iso
65/35 Brass 'O'	Exp.	248	110	0.33	56	≤ 92	Cu Zn 35 426/1
	Iso	260	110	0.375	50	≤ 100	

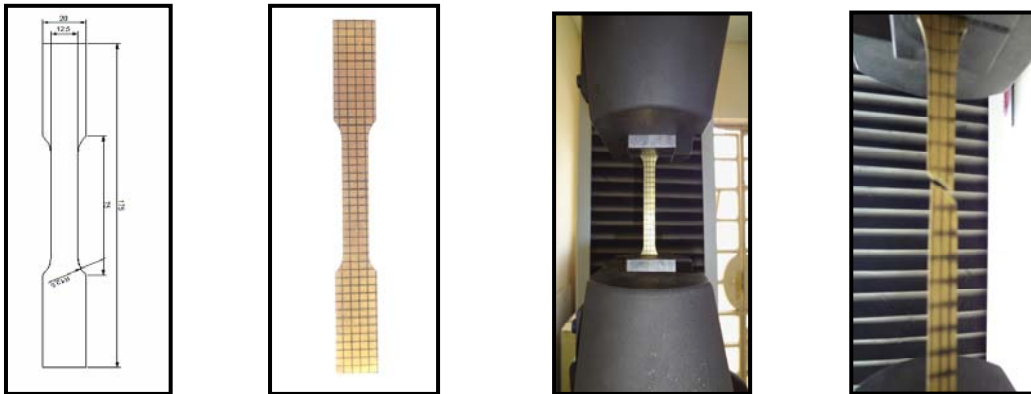

Figure (7) Tensile test of Brass (65-35) specimen.

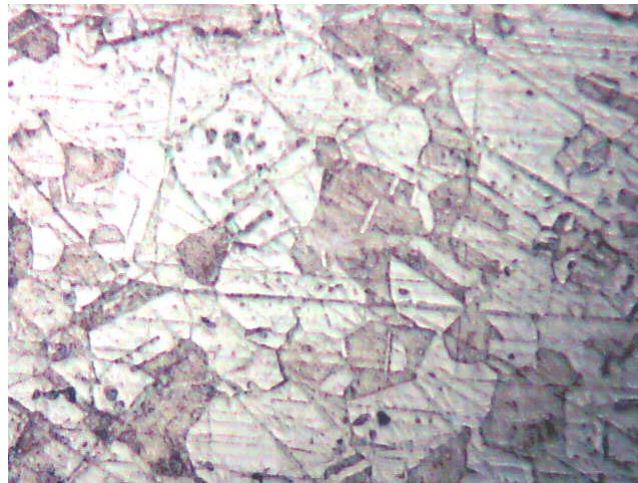

Figure (8) Primary Microstructure of the Brass 65-35 blank (x500).

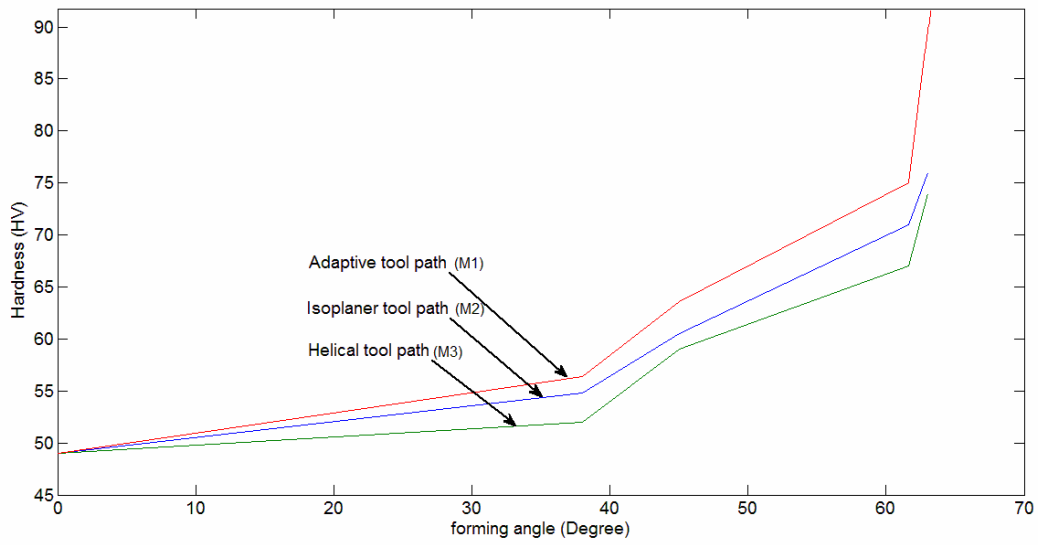

Fig. (9) Illustrates relation between hardness and forming angle of the three toolpath.

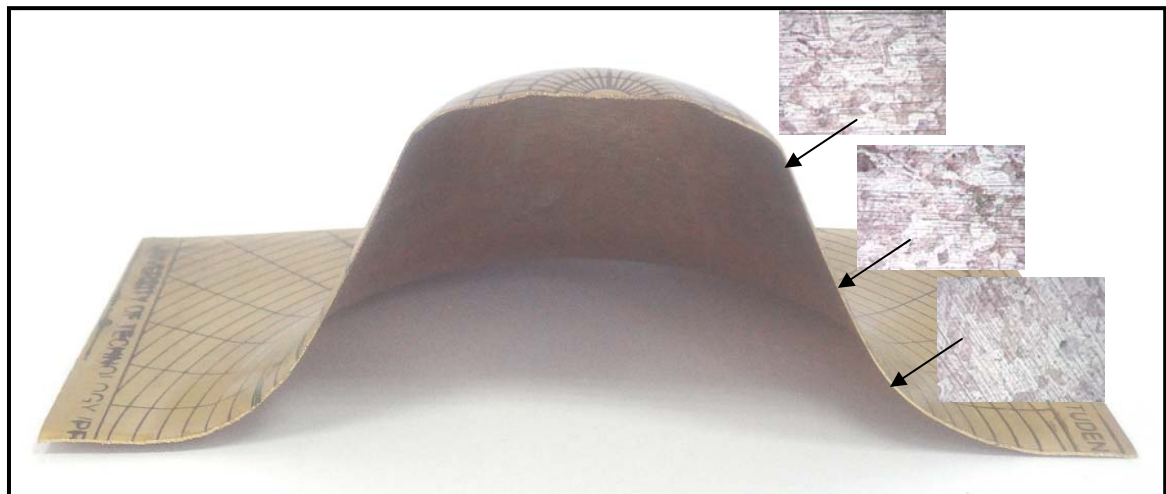
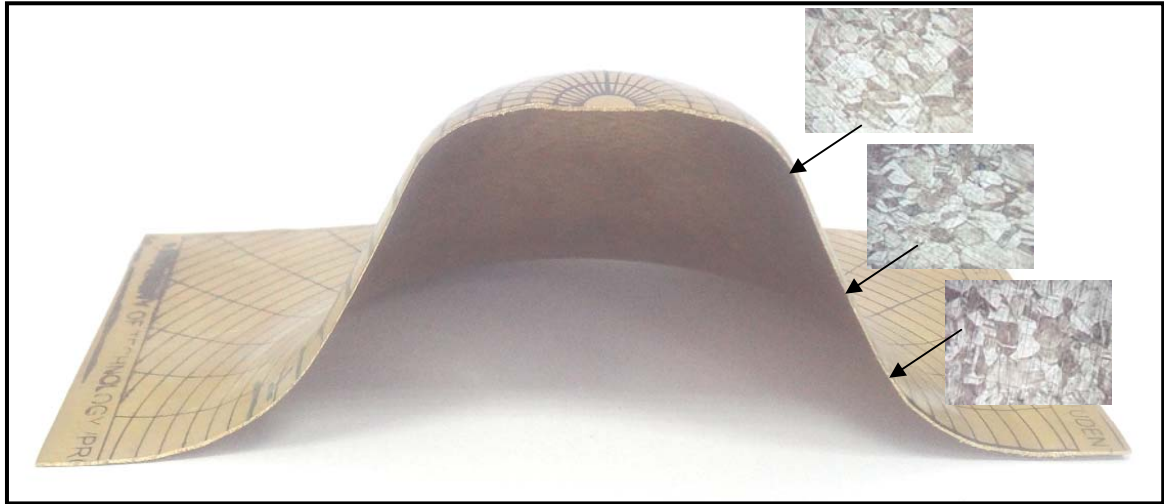
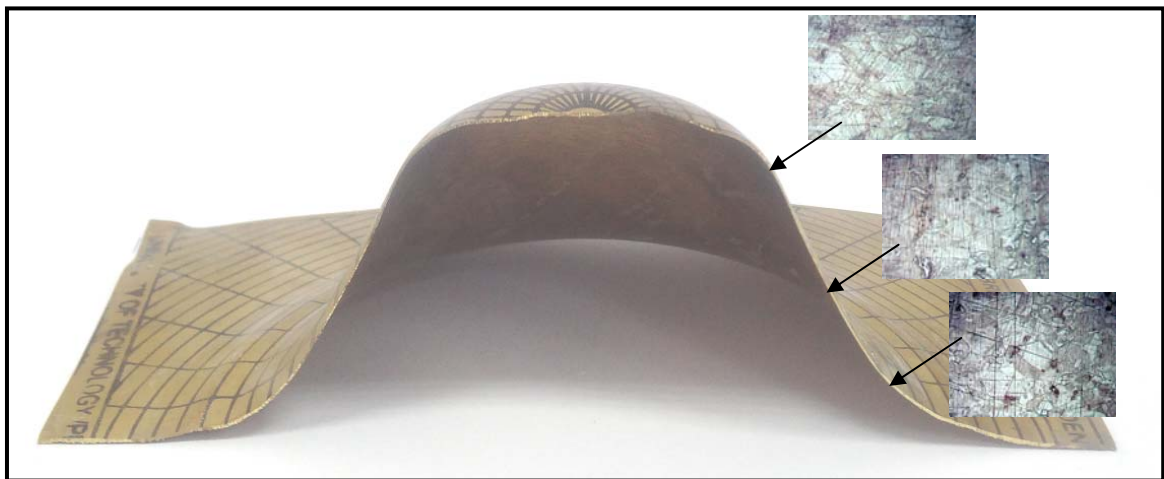

Fig. (10) Microstructure of brass in Isoplaner tool path (M1)





**Fig. (11) Microstructure of brass in Adaptive tool path(M2)**



**Fig. (12) Microstructure of brass in Helical tool path(M3)**