



DESIGN AND SIMULATION OF POWER FACTOR CORRECTION FOR AC/DC CONVERTER

Amina Mahmoud Shaker

. Ass. Prof. Dr. Ali M. Salih

Prof. Dr Kais S. Ismail

Al Nahrin University

Baghdad University

ABSTRACT

One of the biggest problems in power quality aspects is the harmonic contents in the electrical system. Most of the current harmonics are due to the nonlinear operation of the power converters and arc furnaces . These harmonics cause overheating of the magnetic cores of transformers and motors beside their effect on the torque –speed of the later . These problems have lead to the creation of design standards for purpose of limiting the allowable harmonics on the power lines, and hence to improve the power factor.

This paper presents two types of power factor correction (PFC) for single phase AC/DC converter, the Boost converter and the Buck- Boost converter. The output of the Boost converter is fixed (400V , 3kW) while the output of the Buck – Boost converter is variable (150-400V, 3kW-1kW) and due to the discontinuous inductor current mode operation of the Buck mode of the Buck- Boost converter an average charge current control is used in the inner current loop control. From harmonic analysis the two types of converters has less harmonics as compared with the IEC1000-3-2 standards. The Buck Boost converter eliminates the problem of high inrush input current produced by the Boost converter type.

الخلاصة

(Current Harmonics) ان واحدة من اهم المشاكل الموجودة في المنظومات الكهربائية هي توافقيات التيار (Non –Linear Operation of Converters) وان اكثر هذه التوافقيات هي نتيجة عمل مغيرات القدرة اللاخطية وافران الشرارة .

تولد هذه التوافقيات حرارة فائقة في القلب المغناطيسي للمحولات بالإضافة الى تأثيرها على خواص العزم _ السرعة للمحركات و هذه المشاكل أدت الى إيجاد حدود قياسية لتحديد هذه التوافقيات في (Torque _ Speed) المنظومات الكهربائية وبالتالي تحسين عامل القدرة. هي احدى مصادر هذه التوافقيات غير (Single Phase Buck – Boost Converter) ان مغيرات (Variable Output) المرغوب فيها وهي تستخدم في بعض التطبيقات التي تحتاج الى خرج متغير و فولتية الخرج (230V- 85) للفولتية ذو طور واحد بأدخال عام (Buck- Boost Converter) لقد تم اقتراح (Outer Voltage Loop) ويتم التحكم بفولتية الخرج بأستخدام حلقتين، حلقة الفولتية الخارجية (400V- 150) متغيرة من بحيث يكون تيار الدخل وفولتية الدخل (Inner Current Loop) و حلقة التيار الداخلية (Voltage Loop) في طور واحد. وعندما يعمل المغير كخافض للفولتية فأن التيار الداخل يكون متقطع لذا تم اقتراح طريقة تحسس معدل الشحنة في حلقة . ولقد تم إيجاد طريقة للتعديل في حلقة التيار (Charge Average Current Sensing) التيار الداخلية عندما تكون فولتية الخرج للمغير متغيرة. (Gain) الداخلية لتغيير الكسب بأستخدام طريقة الكشف عن قمة فولتية الدخل (Inrush Current) كما تم اقتراح دائرة لتحديد تيار البدء (Peak Input Voltage Detection). تم احتساب توافقيات الدائرة المقترحة ووجد بأنها اقل بالمقارنة مع المواصفات القياسية كما ان كفاءة الدائرة اعلى في حالة الدخل العالي من الدخل الواطي.

KEY WORDS

Boost converter, Buck – Boost converter, Power Factor Correction (PFC), current harmonics.

INTRODUCTION

Most modern electronic apparatus use some form of AC to DC power conversion within their architecture , and they draw pulses of current from the AC network during each half cycle of the supply waveform. The amount of reactive power drawn by a single apparatus may be small , but within a typical large number of these apparatus the amount of reactive power is large and hence the amount of current harmonics are also high.

The effect of power factor and harmonics generated by equipment that can be connected to the public mains network is a matter of concern today. These harmonics must be filtered and this has led to the creation of EN 61000-3-2 standards which is adapted by the European Community [1].

Boost , Buck – Boost converter is one type of AC/DC converter which is either for step up or step up- step down respectively. Many researchers have investigated in the field of power factor correction of AC/DC converter , a three phase Buck –Boost converter is presented in [2], the converter with an additional current loop and a circuit switches which switches between Buck and Boost stages using two transistors while a single phase Buck –Boost

converter with two current feedback loop is presented in [3] and [4], the model used two transistors signal to generate the pulse width modulation (PWM) of the Buck – Boost switches. A single phase Buck – Boost with variable output is presented in [5]. A current programmed control for cascade two switches Buck- Boost converter is presented in [6] and it provided a variable output. A computer model for common switch mode control with average and conventional cycle by cycle switching operation mode for Buck – Boost is presented in [7]. A two switch Boost interleaved Buck- Boost converter is presented in [8] and it has the capability of producing both step-up and step down conversion with lower switches voltage stress.

POWER CIRCUIT DESIGN

This work presents a Boost converter with fixed output (400 V, 3kW) and a power factor preregulator (UC3854) is used in order to improve the power factor (as shown in figure 1) in such a way that the input current is forced to follow the sinusoidal input voltage. Two loops are used to control the output voltage and the input current, the outer voltage loop and the inner voltage loop [9].

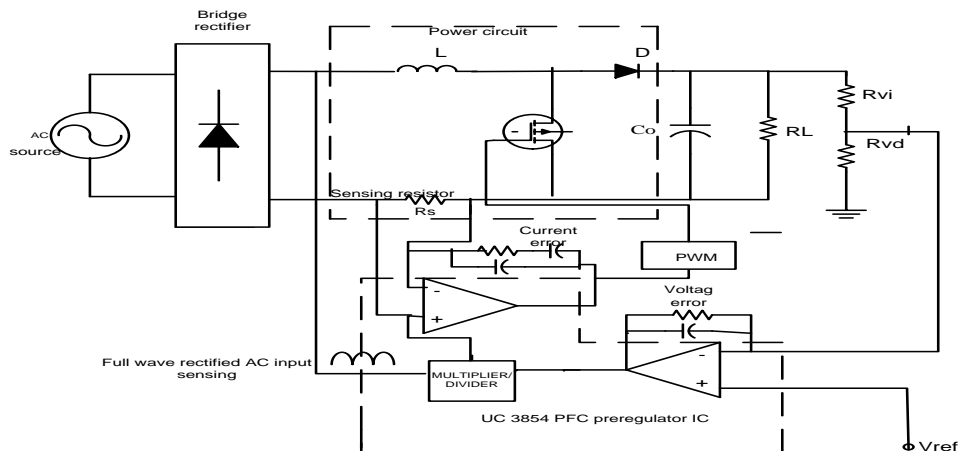

Fig(1) Power factor correction for Boost converter AC/DC Converter(UC3854)

The second converter is the Buck – Boost converter shown in figure 2, the converter is either operate in boost mode in such away that the output voltage is higher than the maximum input voltage or in Buck Boost mode where the output voltage is lower than the maximum input voltage. Figure 3 shows the two operation mode of the Buck Boost converter.

The output inductor employed in the converter provides the energy storage and filtering. The current flowing through it has a triangular waveform. In selecting the inductance a compromise has to be found between high rating required for diminishing the ripple, and a low rating required for quick response to load changes. The peak inductor current is the sum of the peak line current and half of the peak to peak high frequency ripple current. The inductor must be designed to handle this current level.

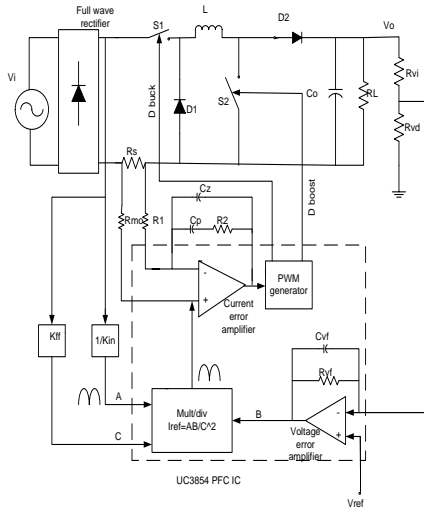

Fig (2) Power factor correction for Buck Boost Converter

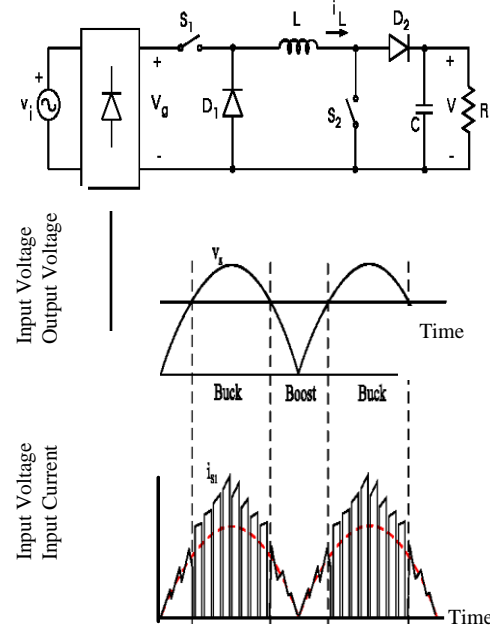

Fig (3) Buck Boost Converter operation modes

• **BOOST CONVERTER INDUCTOR DESIGN:**

The Boost converter inductor is decided according to the minimum rms input voltage then

$$I_{peak} = \frac{\sqrt{2}P_{in}}{V_{i,rms}} \tag{1}$$

where I_{PEAK} is the maximum input current, P_{in} is the input power to the converter and $V_{i,rms}$ is the root mean square of the input voltage.

Since in steady state the time integral of the inductor voltage over one time periods must be zero [10], therefore

$$v_i t_{ON} + (v_i - V_o) t_{OFF} = 0 \tag{2}$$

where v_i is the instantaneous value of the input voltage, t_{ON} is the on time of the switch, V_o is the output voltage of the converter and t_{OFF} is the off time of the switch.

Dividing both sides by T_s Where T_s is the switching frequency and rearranging terms yield

$$\frac{V_o}{v_i} = \frac{1}{1-d} \tag{3}$$

where d is the duty cycle of the ON time of the boost switch.

During the ON period



$$V_L = L \frac{di_L}{dt} \quad (4)$$

where di_L is the inductor ripple current

$$dt = dT_S = \left(1 - \frac{v_i}{V_o}\right) T_S \quad (5)$$

then

$$L \geq \frac{V_{i,\max} T_S}{di_L} \left(1 - \frac{V_{i,\max}}{V_o}\right) \quad (6)$$

• BUCK- BOOST INDUCTOR DESIGN:

The value of inductance is decided depending on the worst operating condition, i.e, when the ripple is X% and it is in continuous conduction during buck mode operation [5]. This occurs when the input voltage is at its maximum peak value and the output is at its minimum value then the peak input current is given by

$$I_{peak} = \frac{\sqrt{2P_{in}}}{V_{i,rms}(\max)} \quad (7)$$

$$\Delta i_L = \frac{X}{100} I_{peak} \quad (8)$$

where Δi_L is the peak to peak ripple of inductor current.

When the converter operates at buck mode, as the Buck switch is ON then,

$$V_L = v_i - V_o = L \frac{di_L}{dt} \quad (9)$$

$$dt = d_1 T_S$$

where d_1 is the duty cycle of the Buck switch, and as

$$d_{1\min} = \frac{V_2}{V_{i\max}} \quad (10)$$

then

$$L \geq \frac{V_o T_S}{\Delta i_L} \left(1 - \frac{V_o}{V_{i\max}}\right) \quad (11)$$

• OUTPUT CAPACITOR:

The output capacitance selection depends on the following factors[10],[11]

- The switching frequency.
- The ripple current.
- The second harmonic ripple current.
- The output ripple.
- The output d.c. voltage.
- The hold up time of the capacitor.

It should be noted that for a given capacitance the capacitor value is proportional to the voltage rating and the maximum energy storage capability which is proportional to the square of the voltage rating. According to the above factors the capacitor with a certain hold up time is given by [10],[11]

$$C_o = \frac{2P_{out}t_{HOLDUP}}{V_o^2 - V_{o\min}^2} \quad (12)$$

where t_{HOLDUP} is the time hold up by the capacitor and it is in the range of 16 to 50 ms[1].

BUCK BOOST CONVERTER CONTROL CIRCUIT :

Active PFC performs much better and is significantly smaller and lighter than the passive PFC circuit. The active PFC can be implemented with a single chip controller, making the circuit relatively simple with minimum number of components .

One of the most popular chip is the Unitrode UC3854 controller which accepts an ac input voltage of 75-275 rms voltage and a frequency of 50 – 400 Hz [9] .

The circuit has two control loop one of them is the fast acting internal current loop . It defines the input current shape to be sinusoidal and force it to be in phase with the input voltage .The second loop is the external voltage loop which regulates the output dc voltage.

The principle of operation of Boost PFC is as follows: The rectified sinusoidal input voltage is fed to a multiplier circuit , providing a current reference to the multiplier and a feed forward signal proportional to the rms value of the line voltage .The filtered DC voltage of Boost PFC is compared to a reference voltage V_{ref} and amplified. The error amplifier sense the variation between the output voltage and the fixed dc reference voltage. The error signal is applied to the multiplier .The multiplier output follows the shape of the input ac voltage. This signal is compared to the current signal sensed by R_s in a Pulse Width Modulation (PWM) circuit. The inductor current waveform follows the shape of the rectified ac line voltage. The gate drive signal controls the inductor current amplitude and maintains a constant output voltage.

A charge control scheme is adopted in this design of the current loop control of the Buck Boost converter since the input current to the converter is discontinuous and its one form of average current control [12-14].Charge control uses a reset integrator to control the average value of a pulsating circuit variable. Figure 4 show the input current for the two cases .

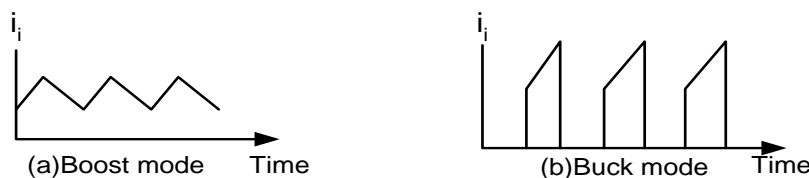

Fig(4) Input current for Boost and Buck mode

Figure 5 illustrates the circuit used in charge average current control used to sense the current in the PFC of the Buck- Boost converter. The i_{s1}/K is hall current sensor which is proportional to the instantaneous input current. Two capacitors C_1 and C_2 are used for integrating the input current alternatively. Transistor T_1 and T_2 employed to quickly discharge the capacitors. The four diode bridge Da-Dd allows i_{s1}/K to charge the capacitor with lower V_x to pick up the higher capacitor voltage which represents the average input current.

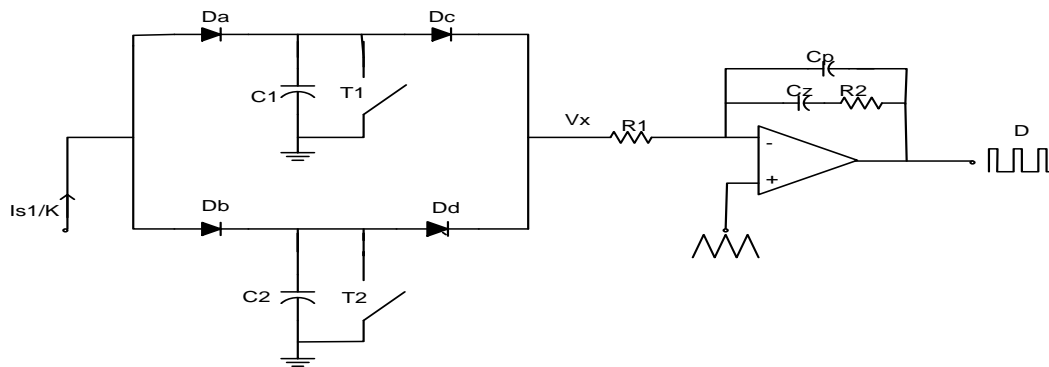

Fig(5) Charge average current sensing used in buck boost converter

SIMULATION RESULTS:

Using the package Orcad 10 the simulation results for the Boost converter given in figure 6 is shown in figure 7(a, b, and c) when the input voltage is 230 V rms, line frequency 50 Hz, output voltage 400 V output power 3kW and the switching frequency is 20kHz. Figure 7 shows the input voltage input current, duty cycle of the boost switch, the output voltage and the input current harmonics. The input current at the first half cycle is 20-25 times the current of the converter. This problem is solved by using the Buck Boost converter shown in figure 8. Figures 9, 10 and 11 show the input voltage, input current output voltage duty cycle of the buck and boost switch and input current harmonics when the output voltage of the converter is 400V, 250V and 150 V respectively.

The input current harmonics for these cases is shown in figure 12 and it shows that the current harmonics is lower than the EIC standards.

The problem of discontinuous input current in Buck mode operation is solved using average charge current control.

CONCLUSIONS :

A power factor correction control for AC/ DC Boost converter is presented and the input current harmonics is eliminated and it is lower than the standards, the output voltage and output power is fixed in this type of converters.

The problem of high inrush input current is solved by using Buck Boost converter and also the output voltage and output power can be made variable in this type of converters

Since the input current in Buck mode of Buck Boost converter is discontinuous , a charge average current control is used to provide the error signal for the inner loop current amplifier. Also the input current harmonics is lower than the standard harmonics current and hence the power factor is within the range 0.993-0.998.

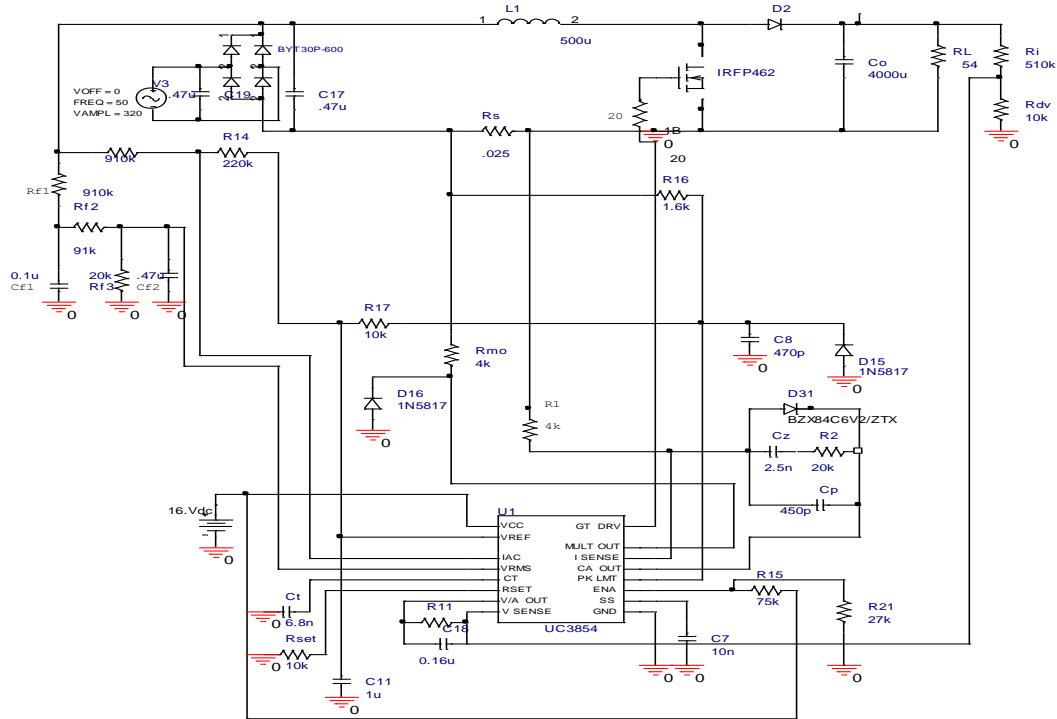

Fig(6) Single phase PFC boost converter schematic(UC3854)

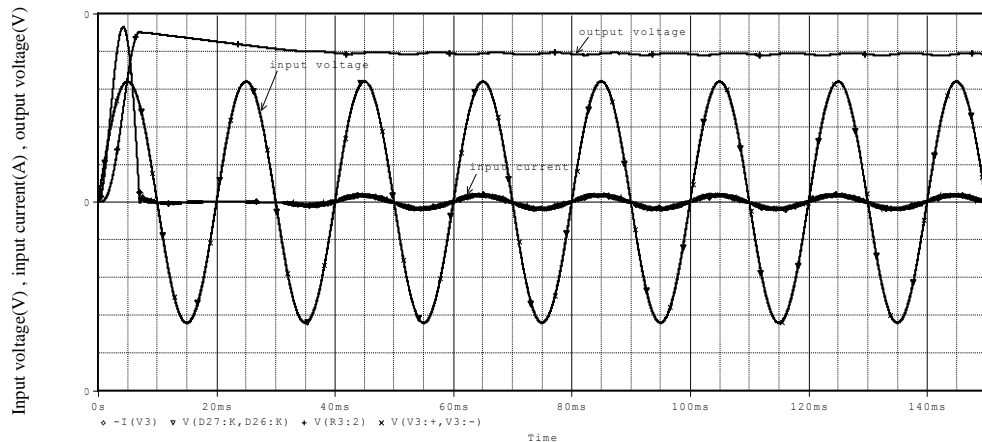

Fig(7)(a) Boost converter input voltage , input current and output voltage $V_i=230V_{rms}$, $V_o=400V$, $P_o=3000W$, $f_s=20kHz$

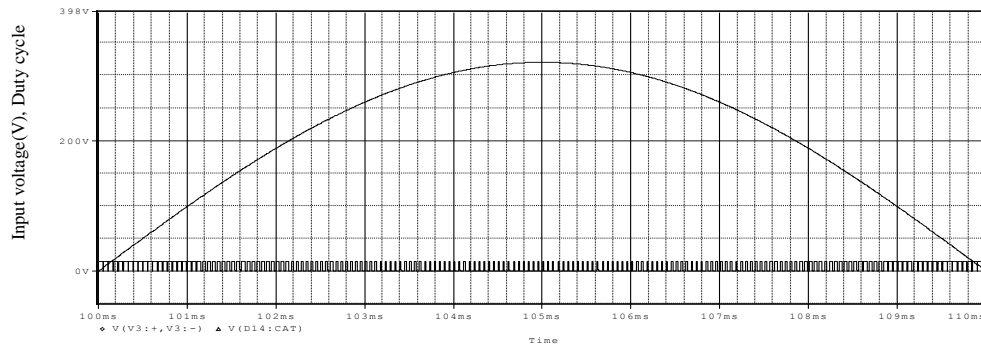

Fig 7(b)Duty cycle of Boost converter
 $V_i=230V_{rms}, V_o=400V P_o=3000W, f_s=20kHz$

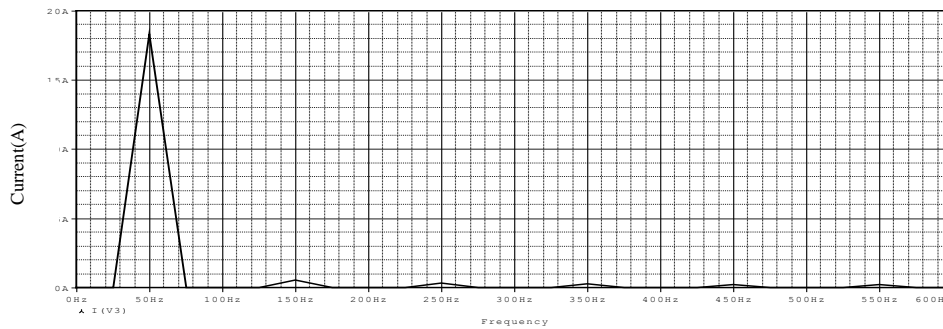

Fig7(c)Input current harmonics for Boost converter
 $V_i=230V_{rms}, V_o=400V P_o=3000W, f_s=20kHz$

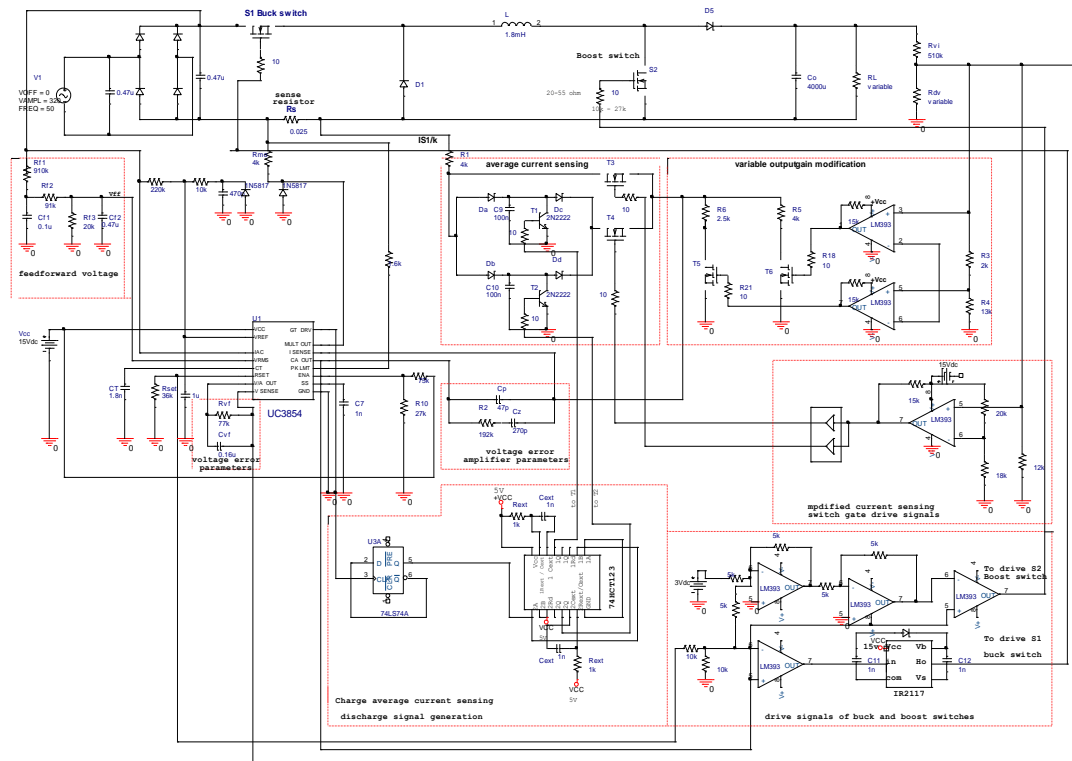

Fig8(a) The connection diagram for PFC single phase Buck Boost converter

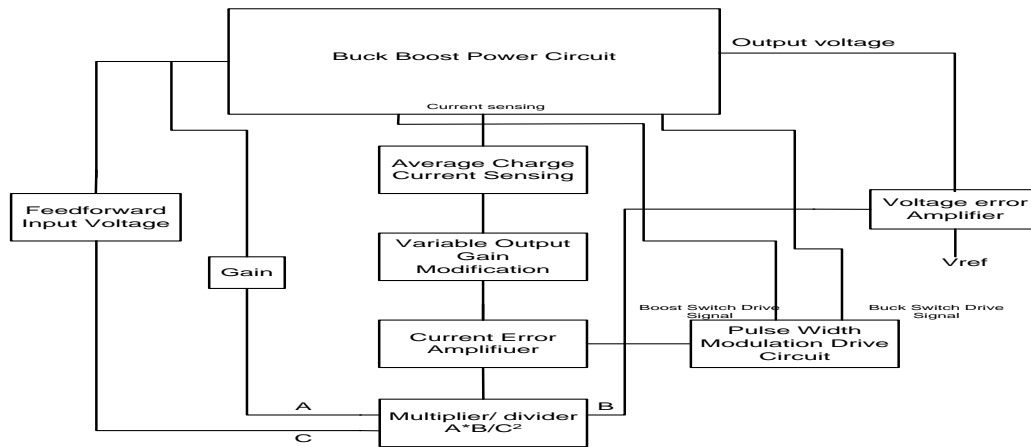

Fig8(b) Buck Boost Converter block diagram

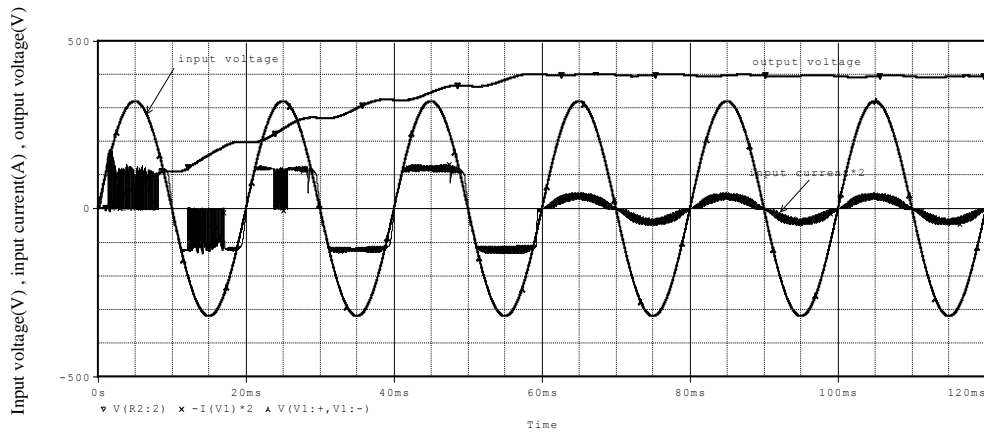

Fig9 (a)Buck –Boost converter input voltage , input current and out put voltage $V_i=230V_{rms}$, $V_o=400V$, $P_o=3000W$, $f_s=20kHz$

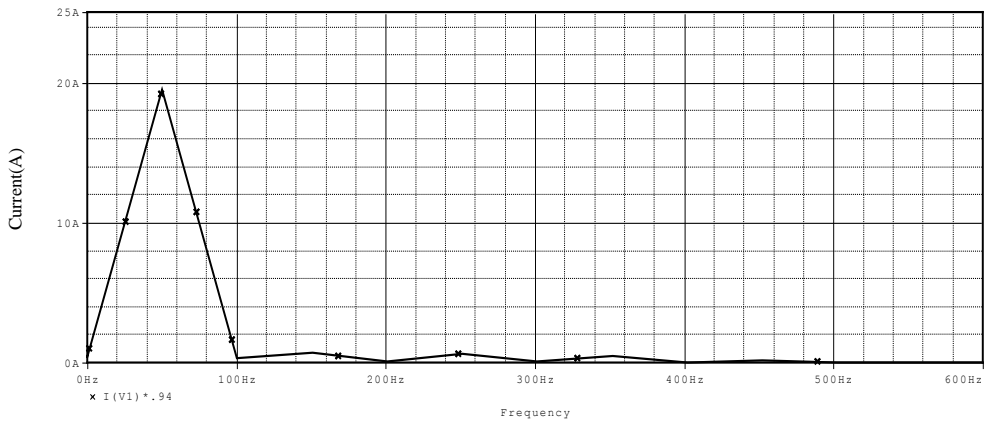

Fig9(b)Input current harmonics of Buck –Boost converter
 $V_i=230V_{rms}, V_o=400V, P_o=3000W, f_s=20kHz$

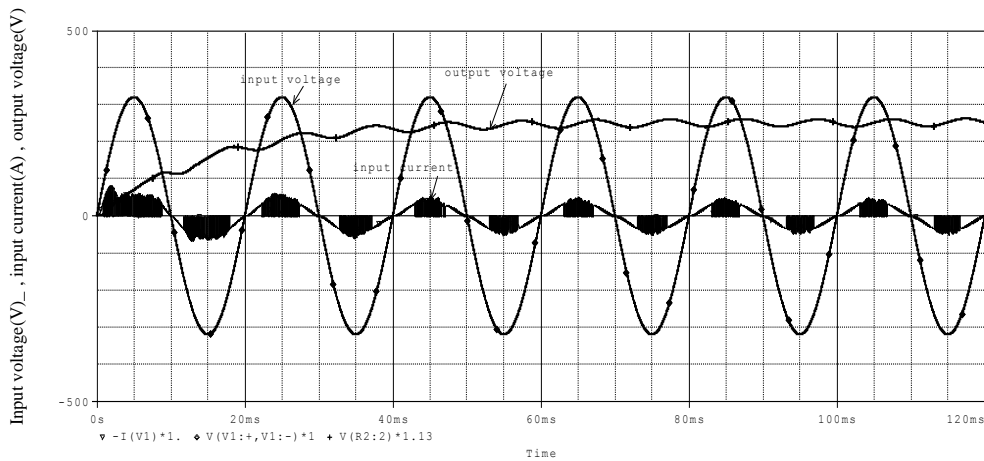

Fig 10(a)Buck- Boost converter input voltage , input current and out put voltage $V_i=230V_{rms}, V_o=250V, P_o=2000W, f_s=20kHz$

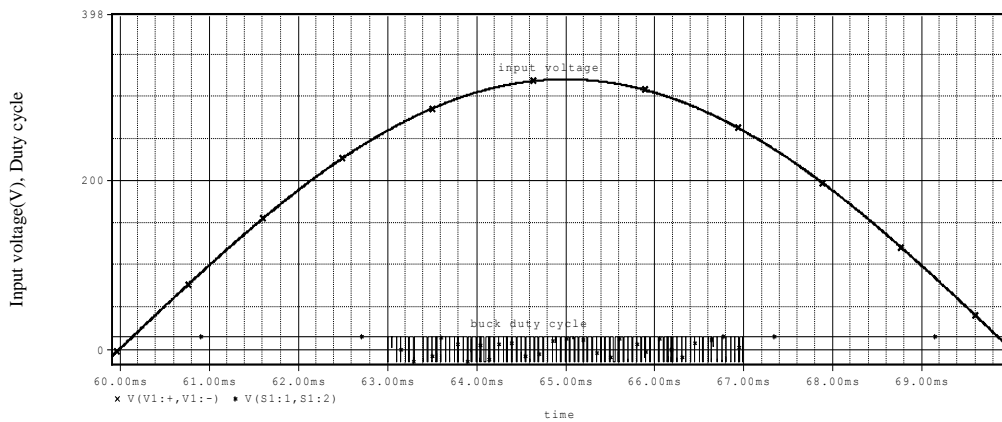

Fig 10(b)Buck switch duty cycle for Buck- Boost converter
 $V_i=230V_{rms}, V_o=250V, P_o=2000W, f_s=20kHz$

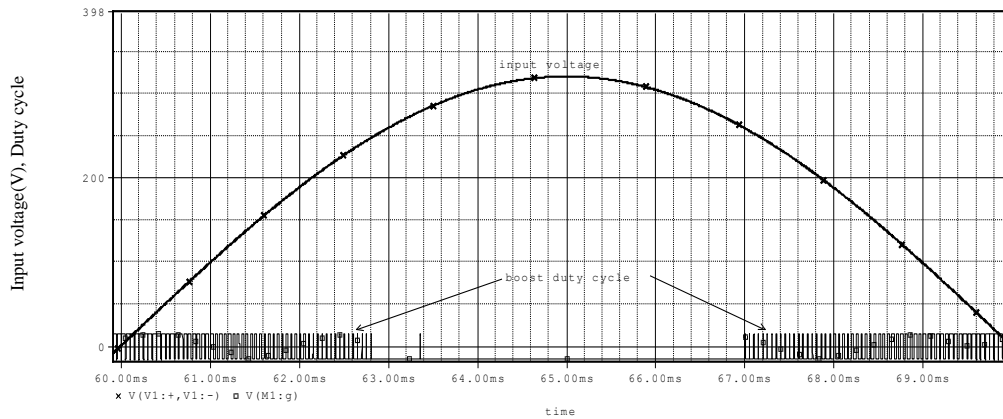

Fig 10(c) Boost switch duty cycle for Buck- Boost converter
 $V_i=230V_{rms}, V_o=250V P_o=2000W f_s=20kHz$

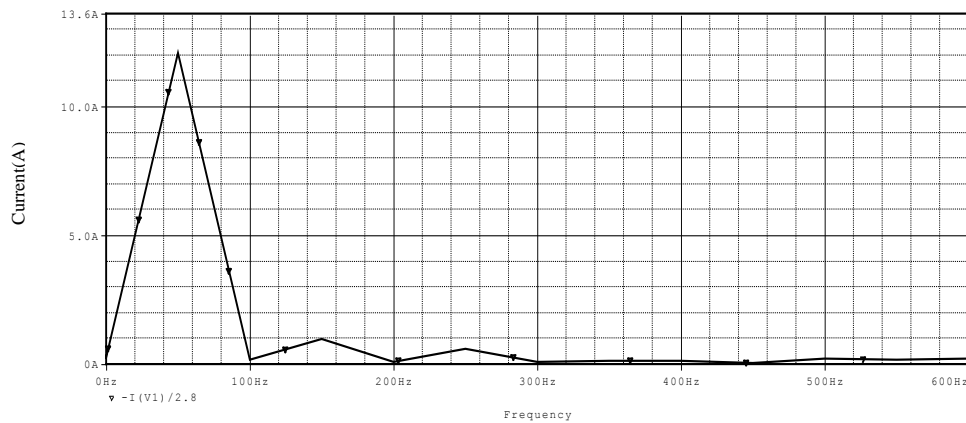

Fig10(d) Input current harmonics for Buck- Boost converter
 $V_i=230V_{rms}, V_o=250V P_o=2000W f_s=20kHz$

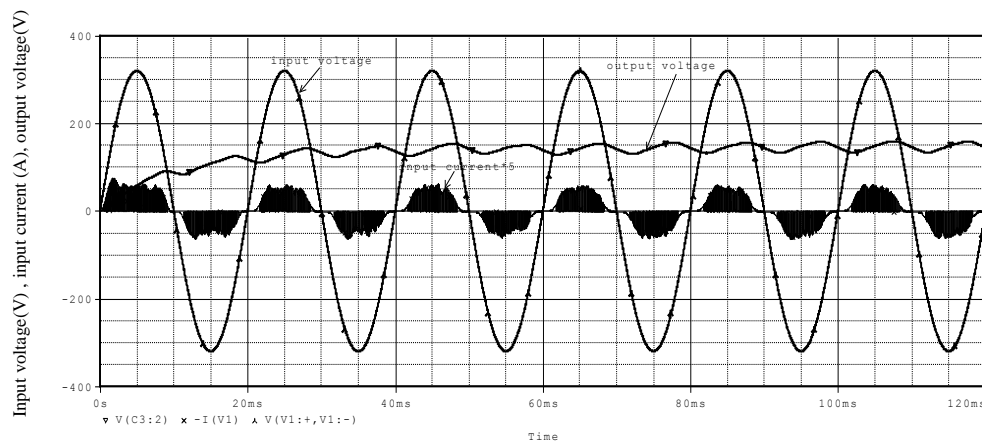

Fig11(a) Buck- Boost converter input voltage , input current and
 out put voltage $V_i=230V_{rms}, V_o=150V , P_o=1000W , f_s=20kHz$

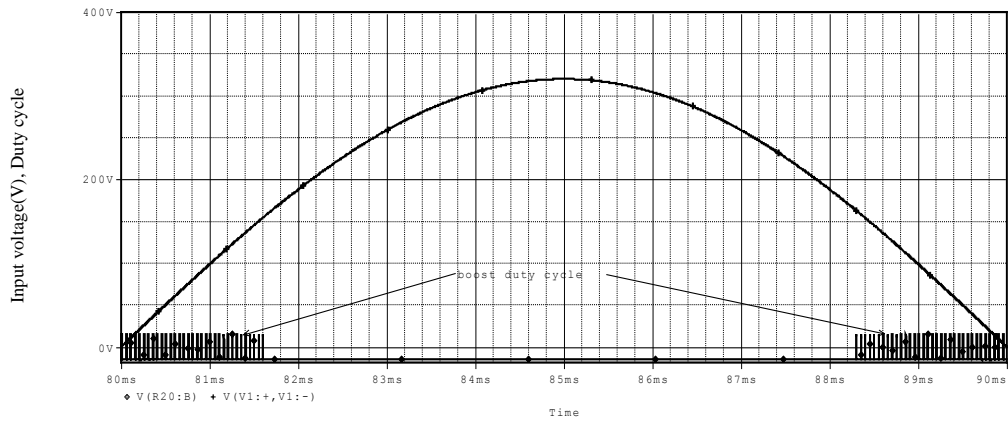

Fig 11(b) Boost switch duty cycle for Buck- Boost converter
 $V_i=230V_{rms}, V_o=150V P_o=1000W, f_s=20kHz$

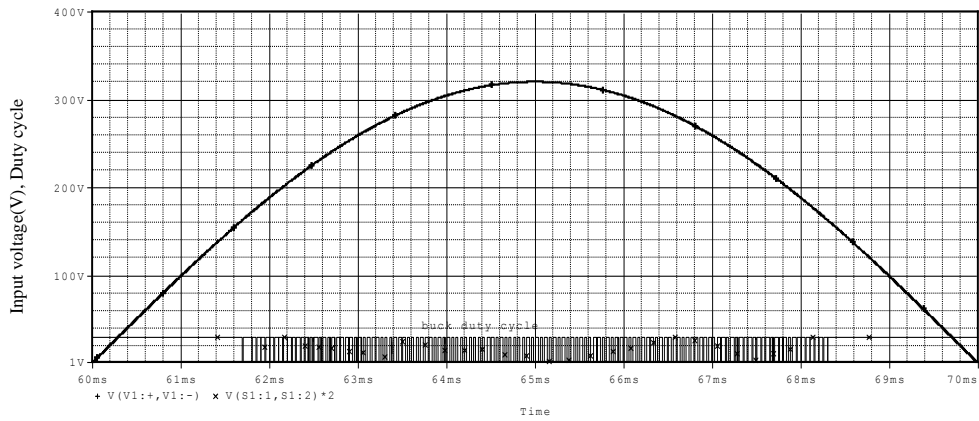

Fig11 © Buck switch duty cycle for Buck- Boost converter
 $V_i=230V_{rms}, V_o=150V P_o=1000W, f_s=20kHz$

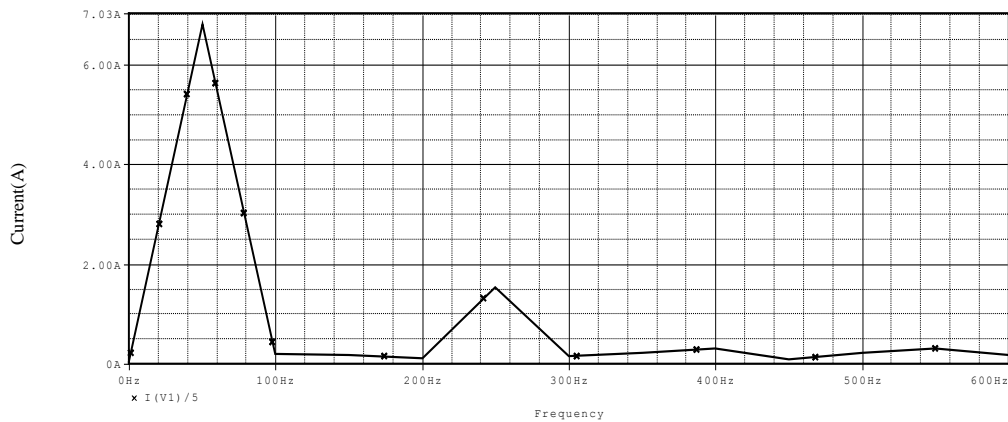
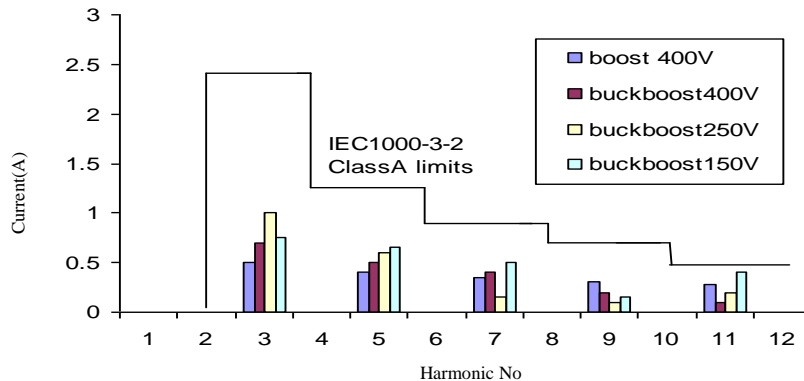

Fig 11 (d) Input current harmonics for Buck- Boost converter
 $V_i=230V_{rms}, V_o=150V P_o=1000W, f_s=20kHz$



Fig` 12 Input current harmonics contents for the different cases

REFERENCES:

- * IEC standard IEC 61000-3-2(2001-10)Ed2.1,“Electromagnetic compatibility (EMC) part 3-2 limits for harmonic current emissions”, 2001.
- * B. Flud, S. Kern and R.1993 Ridely “Combined buck and boost power factor controller for three phase input” IEEE, Poer Electronics and Applications ,1993, fifth European Conference Vol , Issue 13-16 , Sep , pp 144-148 vol .7.
- * R. Ridely, S. Kern and B. Flud 1993“ Analysis and design of a wide range PFC circuit for three phase application” IEEE , Applied power electronics conference , volume, issues 7-11 march, pp 299-305.
- * M. Chanen, K. AL-Haddad and G.Roy1993, “A new single phase buck boost converter with unity power factor” , IEEE, Industry applications society , annual meeting , Volume , issue 2-8 Oct. 1993 pp 785-792 volume 1.2.
- * Y. Zhao,1998“Single phase power factor correction with wide output voltage range” M.Sc. thesis ,Virginea University .
- * G.K. Andersoen and F. Blaabjerg2001 “Current programmed control of a single phase two switch buck boost power factor correction”, IEEE, Applied power electronics conference Volume issue 1 pp 350-356.
- * G.G. Michael “ Averaged and cycle by cycle switching model for buck , boost , buck boost and cuk converters with common average switching mode” Texas Tech University e mail Michael @ coez.coe.ttu.edu.
- * J. Chen , D. Maksimovic and R. Erickson2006, “ Analysis and design of a low stress buck boost converter in universal input PFC application” IEEE transaction on power electronics , Volume 21, No 2 march.
- * C. Silva2001 “Power factor correction with the texas instrumentation catalogue UC3854” .
- * N. Mohan , T.M. Undeland and W.P1995. Robbins “Powert electronics converters, applications and design” John wily and son, Inc . Second Edition , New York .



- * M. O. Loughlin 2002“ UCC3819 , 250 W power factor correction (PFC) boost flower preregulator design , Texas Instrumentation Literature No.SLOA 296,.
- * W. Jang , F.C Lee , R. B. Ridley and I. Cohen1992 “ Charge control modeling analysis and design” IEEE PESC pp 503-511.
- * V. Vorperian 1993“ the charge controlled PWM switch” IEEE PESC pp 533-543.
- * W. Jang ,y. Jung , G.C .Hua andF.C Lee1993 “ Power factor correction with flyback converter imploying charge control” IEEE PESC pp 293-308 , 1993.