



## ENTROPY METHOD AS CRITERIA FOR ANALYSIS OF A STEAM POWER PLANT

Lecturer Dr. Moayed Razoki Hasan  
University of Technology / Mech. Eng. Dept.

### ABSTRACT

In this paper a theoretical analysis of South Baghdad and Dura power plant is carried out according to second law of thermodynamic depending on entropy (irreversibility coefficient or lost work) method instead of exergy (availability) method. In the used entropy method. The power plant is divided into main blocks ( boiler, turbine, condenser, and feed water heater and pumps ). The irreversibility losses and coefficient for each block are calculated and then the overall irreversibility and thermal efficiency of the plant are calculated. The results of this work are compared with previous results, that depending on exergy method. The comparison of results show that both methods give approximately the same results since both of them rely the 2<sup>nd</sup> law of thermodynamic. Entropy method is simple and intellectually and intuitively satisfying and giving direct relationship between components losses of power plant and its overall efficiency.

### الخلاصة

يتناول البحث الحالي تحليل محطة جنوب بغداد ومحطة الدورة الحرارية باعتماد طريقة الانتروبي (معامل اللانعكاسية او الشغل المفقود) بدلا من طريقة المتاحة. في طريقة الانتروبي المستخدمة، يتم تقسيم محطة القدرة الى اجزاء رئيسية ( المرجل، التوربين، المكثف، و المسخنات و مضخات ماء التغذية ). يتم حساب معاملات و خسائر اللانعكاسية لكل جزء ثم بعد ذلك يتم حساب اللانعكاسية الكلية للمحطة و كفاءتها الحرارية. اظهرت مقارنة النتائج مع نتائج الاعمال السابقة لتحليل المحطتين باعتماد طريقة المتاحة. لقد اشارت النتائج بان الطريقتين تعطيان نتائج متقاربة جداً مع افضلية لطريقة الانتروبي التي تمتاز بسهولة مع امكانية الربط المباشر لخسارات كل جزء من اجزاء المحطة مع الكفاءة الكلية للمحطة.

**KEYWORDS: Steam Power Plant, Analysis, Entropy Method**

### INTRODUCTION

With increasing fuel prices and the possibility of diminishing supplies in the years a head, the importance of developing systems which make efficient use of energy is apparent. The second law of thermodynamic method of analysis is particularly suited for furthering the goal of more efficient

energy use, for it identifies the locations, types, and the true magnitudes of energy resources waste and loss, such method can also be used to guide steps taken to reduce inefficiencies.

According to this second law different criteria are defined for analysis the performance of power plants based on the concept of exergy (availability). If all of these criteria are used, they must all give the same results. Although availability pinpointed the real losses of a steam power plant, it is difficult, complex and can not gives direct relationship between component losses and overall efficiency of plant. Thus, the criteria for selecting the best procedure to evaluate thermodynamic analysis should be, best ease of use, best degree of correspondence with the viewpoint and background of intended users and greatest breadth of application. On these grounds, the entropy method (lost work) approach was believed to be superior to other approaches in common use (**Seader 1986**).

The purpose of this work is to analyze performance of South Baghdad and Dura power plants according to 2<sup>nd</sup> law of thermodynamic depended on the concept of entropy method instead of exergy method. Then compare the results with that which obtained previously by other researches (**Hashem and Murad 1998**) and (**Mathure et.al. 2000**) depending on exergy method.

## EXERGY METHOD ANALYSIS OF THE THERMAL POWER PLANT

The processes in steam turbine plant are steady flow processes .Where the general form of the exergy value was calculated from the following formula (**Hashem and Murad 1998**), (**Moran 1982**) and (**Yunus 1994**) :

$$e = (h - T_o.s) - (h_o - T_o.s_o)$$

For exergy analysis the plant was divided in to the following main blocks: steam boiler, steam turbine, steam condenser, feed water heaters and feed water pump. The exergy losses in each block can be defined as follows (**Hashem and Murad 1998**) and (**Mathure et.al. 2000**) :

### Steam Boiler

The total exergy losses of boiler are given,

$$E_{Lb} = E_f - \Delta E_w \quad (1)$$

This total exergy losses of boiler are divided into three main losses,

#### a- Combustion Losses

$$E_{Lc} = m_g.T_o.C_{pg}.\ln\left(\frac{T_c}{T_o}\right) \quad (2)$$

Where, combustion temperature ( $T_c$ ) is roughly given by,



$$m_f.C.V. = m_g.C_{pg}.(T_c - T_o)$$

### b- Exhaust Losses

$$E_{Lex} = m_g.(h_{ex} - h_o) - T_o.(S_{ex} - S_o) \quad (3)$$

Where,  $h_{ex} = C_{pg} \cdot T_{ex}$  ,  $s_{ex} = C_{pg} \ln (T_{ex} / T_o)$

### c- Heat Transfer Losses

Exergy losses due to heat transfer ( $E_{Lht}$ ),

$$E_{Lht} = E_f - \Delta E_w - E_{Lc} - E_{Lex} \quad (4)$$

Thus, the total exergy losses of boiler can be calculate from,

$$E_{Lb} = \mathbf{Eq. (2)} + \mathbf{Eq. (3)} + \mathbf{Eq. (4)}$$

And the second law efficiency of boiler can be calculated as,

$$\eta = \frac{\Delta E_w}{E_f} \quad (5)$$

### Steam Turbine

$$E_{Lt} = \Delta E_t - W_{out} \quad (6)$$

And 2<sup>nd</sup> law efficiency of turbine,

$$\eta = \frac{W_{out}}{\Delta E_t} \quad (7)$$

### Steam Condenser

Condenser effectiveness = (exergy gain by surrounding) / (exergy losses by steam through the condenser) (8)

$$\text{exergy gain by surrounding} = Q_{rej} \left( \frac{T_{max} - T_{min}}{T_{max}} \right) \quad (9)$$

Where,

$T_{max}$  – steam temperature at condenser inlet

$T_{\min}$  – surrounding temperature

Whereas, exergy losses through the condenser is equal to the exergy losses by steam.

### Feed Water Heater

$$\text{Exergy losses} = \Sigma \text{ exergy input} - \Sigma \text{ exergy output} \quad (10)$$

$$\text{the effectiveness of feed water heater} = (\text{exergy gain by cold water})/(\text{exergy lost by steam}) \quad (11)$$

### feed water pump

$$\text{Exergy losses} = W_{\text{input}} - \text{exergy increasing of working fluid} \quad (12)$$

$$\text{Effectiveness of pump} = (\text{exergy increase of working fluid})/(W_{\text{input}}) \quad (13)$$

According to 2<sup>nd</sup> law steam cycle efficiency is given as,

$$\eta_{IIc} = \frac{W_{\text{output}}}{m_s \cdot \Delta e_w} \quad (14)$$

So from **Eq. (5)**  $\eta_{IIb} = m_s \cdot \Delta e_w / E_f$ ,

then the 2<sup>nd</sup> law efficiency of the power plant is given as,

$$\eta_{II\text{plant}} = \eta_{IIc} \cdot \eta_{IIb} \quad (15)$$

The schematic diagram of one unit of South Baghdad power plant is shown in **Fig.1** . The description data of its steam cycle is given in **Table.1 (Mathur et.al. 2000)**. Whereas, the schematic diagram of one unit of Dura power plant and the description data of its steam cycle are shown in **Fig.2** and **Table .2**, respectively (**Hashem and Murad 1998**) .

Using **Tables. 1** and **2** and above equations, exergy analysis of each component was calculated for South Baghdad (**Mathur et.al. 2000**) and Dura (**Hashem and Murad 1998**) and the results are summarized in **Tables. 3** and **4** , respectively.

## ENTROPY METHOD

According to (**Gashteen and Varkevker 1986**) and (**Yunus 1994**) irreversibility losses (lost work) are given as,

$$\text{Irreversibility losses} = W_{\text{is}} - W_{\text{act}}$$

$$\text{Irreversibility losses} = (Q_{\text{add}} - Q_{\text{rej}})_{\text{rev}} - (Q_{\text{add}} - Q_{\text{rej}})_{\text{ire}}$$

$$\text{Irreversibility losses} = (Q_{rej})_{irre} - (Q_{rej})_{rev} \tag{16}$$

But for reversible engine,

$$\Delta s_{sys} = \Sigma \Delta s = \frac{(Q_{rej})_{rev}}{T_o} - \frac{Q_{add}}{T_1} = 0$$

Then,

$$\frac{(Q_{rej})_{rev}}{T_o} = \frac{Q_{add}}{T_1} \tag{17}$$

For irreversible engine,

$$\Delta s_{sys} = \Sigma \Delta s = \frac{(Q_{rej})_{irre}}{T_o} - \frac{Q_{add}}{T_1}$$

From **Eq. (17)**,  $\frac{Q_{add}}{T_1} = \frac{(Q_{rej})_{rev}}{T_o}$ , then

$$\Delta s_{sys} = \frac{(Q_{rej})_{irre}}{T_o} - \frac{(Q_{rej})_{rev}}{T_o}$$

$$T_o \cdot (\Delta s)_{sys} = (Q_{rej})_{irre} - (Q_{rej})_{rev} \tag{18}$$

Sub. **Eq. (16)** in **Eq. (18)**, then

$$\text{Irreversibility losses} = T_o (\Delta s)_{sys} = T_o \Sigma \Delta s \tag{19}$$

For example for the arbitrary system shown below the irreversibility losses can be calculated as follows,

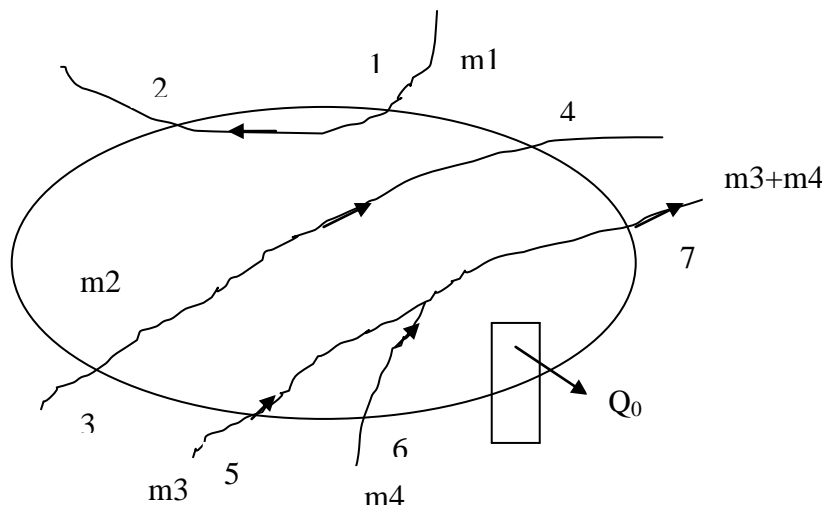

$$\text{Irreversibility losses } (\Phi) = T_o [ m_1.s_2 + m_2.s_4 + (m_3 + m_4).s_7 - m_1.s_1 - m_2.s_3 - m_3.s_3 - m_4.s_6 + Q_o / T_o ]$$

$$\Phi = T_o \cdot [\sum_{i=1}^n (m_i \cdot s_i)_{out} - \sum_{i=1}^m (m_i \cdot s_i)_{in}] + Q_o \quad (20)$$

If there is no heat transfer across the boundary ( $Q_o = 0$ ) then,

$$\Phi = T_o [ \sum_{i=1}^n (m_i s_i)_{out} - \sum_{i=1}^m (m_i s_i)_{in} ] \quad (21)$$

From **Eq.(21)** irreversibility losses can be calculated depending only on the change of entropy. This is why this method was given name of entropy by (**Gashteen 1963**) . Irreversibility coefficient ( $\Omega$ ) for each component of the power plant is equal to,

$$\Omega_i = \Phi_i / (\text{exergy input to the plant}) \quad (22)$$

And the overall irreversibility coefficient for any power plant,

$$\Omega_{total} = \frac{\sum_{i=1}^n \Phi}{input}$$

$$\Omega_{total} = \Omega_1 + \Omega_2 + \Omega_3 \dots \dots \dots \Omega_n = \sum_{i=1}^n \Omega_i \quad (23)$$

Plant thermal efficiency is defined as,

$$\eta = \frac{output}{input} = \frac{input - \sum losses}{input}$$

$$\eta = \frac{input - \sum_{i=1}^n \Phi_i}{input} = 1 - \sum_{i=1}^n \Omega_i \quad (24)$$

By using entropy method to analyze thermal power plant, the plant was divided into main blocks and irreversibility losses for each block was calculated according to **Eqs.(20) or (21)** and then irreversibility coefficient for each block was calculated from **Eq. (22)** . The overall irreversibility coefficient of the plant was found from **Eq. (23)** and then from **Eq. (24)** the thermal efficiency of plant can be calculated (**Gashteen and Varkevker 1986**).

The main blocks of thermal power plants and their irreversibility coefficient are as the following,

### Steam Boiler

The total irreversibility losses of steam boiler are divided into three parts,

- (a) Exhaust losses (b) combustion losses (c) heat transfer losses.



(a) Exhaust losses

These losses are calculated as follows,

$$\text{Irreversibility exhaust losses} = Q - Q \cdot \eta_b$$

$$\text{Irreversibility exhaust losses} = Q (1 - \eta_b) \tag{25}$$

Where  $Q = (m_s \cdot \Delta h_w) / \eta_b$

(b) Combustion losses

Combustion leads to appearance irreversibility losses which are depended on temperature of combustion.

Thus when this temperature increases the irreversibility losses decreases as shown on T-S diagram below :

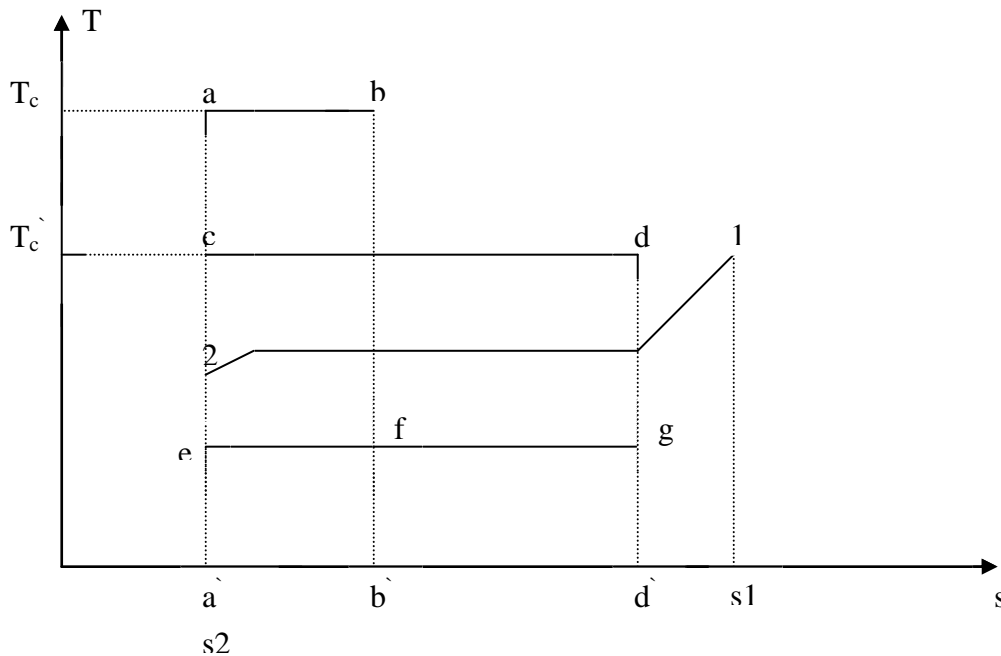

The area  $abb'a$  represents the heat released during combustion at  $T_c$ . The equal area  $cdd'c$  represents the same heat released when combustion occurs at  $T_{c'}$ .

$$\text{Irreversibility losses of combustion at } (T_c) = Q - Q \cdot \left[ \frac{T_c - T_o}{T_c} \right] = Q \cdot \frac{T_o}{T_c} \tag{26}$$

$$\text{Irreversibility losses at temperature } (T_{c'}) = Q \cdot \frac{T_o}{T_{c'}} \tag{27}$$

So  $T_{c'} < T_c$ , then irreversibility losses at  $T_c$  are less than that at  $T_{c'}$ . These losses are shown on T-s diagram which are equals to area  $efb'a'e$  and  $egd'a'e$  at  $T_c$  and  $T_{c'}$  respectively.

(c) Heat transfer losses

$$\text{Irreversibility losses} = T_o \cdot (m_s \cdot (s_1 - s_2) - \frac{Q}{T_c}] \quad (28)$$

When combustion temperature is  $T_c$ . whereas these losses at  $T_c$  become,

$$T_o \cdot (m_s \cdot (s_1 - s_2) - \frac{Q}{T_c}) \quad (29)$$

From **Eqs.(28)** and **(29)** it is clear that these losses are increasing when combustion temperature is increasing. Thus, **Eq.(26) + Eq.(28)** and **Eq.(27) + Eq.(29)** give the sum of irreversibility losses due to combustion and heat transfer at different combustion temperatures. From which a conclusion can be achieved that irreversibility losses due to combustion and heat transfer are given as,

$$m_s \cdot T_o \cdot (s_1 - s_2) \quad (30)$$

Where  $s_1$  &  $s_2$  are the entropy of working fluid at outlet and inlet of boiler respectively **Eq.(30)** is valid whatever the temperature of combustion is.

Thus, the total irreversibility losses of steam boiler can be calculated as follows,

$$\text{Total irreversibility losses of boiler} = \mathbf{Eq.(25) + Eq. (30)}$$

### Steam Turbine

Irreversibility losses of turbine can be calculated from **Eq. (21)**.

### Steam Condenser

This irreversibility losses can be calculated from **Eq.(20)** in which  $Q = m_s \Delta h_s$

### Feed Water Heaters And Pumps

This can be calculated from **Eq. (21)**

### Mechanical And Generator Losses

These can be calculated as follows,

$$\text{Mechanical irreversibility losses} = w_t - \eta_m \cdot w_t \quad (31)$$

$$\text{Generator irreversibility losses} = \eta_m \cdot w_t - \eta_m \cdot \eta_g \cdot w_t \quad (32)$$

For all above components the irreversibility coefficient ( $\Omega$ ) for each component can be calculated by dividing  $\Phi_{\text{component}}$  by fuel exergy, which is in our calculated equal to  $m_f \cdot C.V$ . Then,





$$\eta = 1 - \sum_{i=1}^n \Omega_i$$

The results obtained from entropy method are summarized in **Table.5** and **6** for South Baghdad and Dura power plant respectively.

## CONCLUSION

- 1- Both exergy and entropy methods give approximately the same results **Figs.3** and **4** ,since the second law of thermodynamic is unambiguous.
- 2- Entropy method (irreversibility) independent on dead state except for the value of  $T_o$ . Whereas the exergy is determined in relative to restricted dead state, which can be some what misleading.
- 3- Entropy method which is simple and easy to apply is superior to exergy method. Since the former method requires only one property (entropy) to obtain the results, while the later method requires two properties (entropy and enthalpy).
- 4- The entropy method is pinpointing the real losses in each component and giving direct relationship between them and the overall efficiency of the plant. By this the effect of inefficient components can be directly reduced to improve the performance of plant.
- 5- The entropy method show that combustion temperature not posses influence on the irreversibility losses of the boiler. This is in contrast with what (**Hashem and Murad 1998**) previously concluded.

## REFERENCES

- Goshteen D.P. (1963), Entropy method for calculation irreversibility losse. Mocko pp.111. (in Russian)
- Goshteen D.P.,verkhevker G.P. (1986), Analysis heat cycles for nuclear power plants. Mocko P.285 (in Russian)
- Hashem H.H, Murad N.K., (1998) Pinpointing the real losses of a steam power plant by using exergy method. (Accepted for publication) in Technical research journal.
- Mathur M.L., sinha S.P. and Oda S.D., 2000, First and second law analysis of a steam power plant" steam and fuel users Association od India, vol.33, No.2.pp.31-36.
- Moran M.J. (1982), Availability analysis: a guide to efficient energy use. America p.260.
- Seader J.D. (1980), Lost work: :a measure or thermodynamic efficiency. Energy.vol.5 pp.757-769.
- Yunus A.C. (1994), thermodynamics an engineering approach. America p.-986.

## NOTATION

C.V.	caloric value of fuel (kJ /kg)
h	specific enthalpy (kJ /kg)
s	specific entropy (kJ /kg.K)
e,E	specific exergy (kJ /kg) , power (W)
$C_p$	Specific heat at constant pressure (kJ /kg K)
T	temperature (K)
Q	total heat (kJ)
W	work (kJ)

### GREEK

$\eta$	efficiency
$\Phi$	irreversibility loss
$\Omega$	irreversibility coefficient
$\Delta$	difference

### SUBSCRIPTS

add	added	irre	irreversible
act	actual	is	isentropic
b	boiler	L	losses
c	combustion	m	mechanical
ex	exhaust	max	maximum
f	fuel	min	minimum
g	gas, generator	o	ambient
ht	heat transfer	rej	rejected
II	second law	rev	reversible
s	steam	sys	system
w	water	t	turbine

Table.1: Description Data Of Steam Cycle For South Baghdad Power Plant (Mathur et.al. 2000)

Pt	mass kg/s	pressure bar	x%	saturation tem.c <sup>0</sup>	h kJ/kg	s kJ/kg.K
1	74.433	87.2	510	301	3414.5	6.7085
2	0.0756	87.2	510	301	3414.5	6.7085
3	74,358	87.2	510	301	3414.5	6.7085
4	0.1767	87.2	510	301	3414.5	6.7085
5	0.051	87.2	510	301	3414.5	6.7085
6	0.1106	71.02	482.222	286.722	3367.3	6.742



7	0.1616	75.84	493.333	291.277	3382.2	6.7336
8	0.0504	75.84	493.333	291.277	3382.2	6.7336
9	0.0315	75.84	493.333	291.277	3382.2	6.7336
10	0.0797	75.84	493.333	291.277	3382.2	6.7336
11	0.8343	71.02	482.222	286.722	3367.35	6.742
12	73.1855	87.2	510	301	3397.3	6.7253
13	5.418	32.9	388.888	239	3199.87	6.83417
14	67.766	32.9	388.888	239	3199.87	6.83417
15	3.9858	16.81	308.888	203.666	3046.129	6.8886
16	63.781	16.81	308.888	203.666	3046.129	6.8886
17	3.377	7.177	215.555	165.888	2876.5	6.9388
18	60.403	7.177	215.555	165.888	2876.5	6.9388
19	4.012	2.7	132.222,0.995	130	2713.5	7.0016
20	56.391	2.7	132.222,0.995	130	2713.5	7.0016
21	4.845	0.792	92.22,0.967	92.888	2539.99	7.1105
22	51.545	0.792	92.222,0.967	92.888	2539.99	7.1105
23	51.545	0.0677	38.333,0.89	38.333	2303.67	7.4246
24	9.0449	0.106	46.788	46.855	195.895	0.6603
25	51.545	0.067	36.15	38.333	151.376	0.5201
26	60.64	0.072	38.388	52.277	160.726	0.5502
27	60.64	14.734	38.388	197.222	160.726	0.5502
28	0.0756	87.2	510	301	3412.24	6.7211
29	0.0756	27.58	224.833	229.222	988.55	2.6143
30	60.64	14.73	39.111	197.244	163.75	0.56
31	8.969	0.103	45.191	45.5	189.21	0.6407
32	0.0315	0.827	97.71	99.555	417.28	1.18509
33	60.64	14.734	39.444	197.222	165.146	0.5645
34	4.925	0.8411	98.111	94.444	2553.7	7.1189
35	8.938	0.102	45	45.233	188.4	0.6382
36	4.0122	0.6895	87.883	89.555	394.95	1.1641
37	60.64	14.245	88.611	195.72	370.997	1.1809
38	60.64	13.755	124.944	194.222	524.28	1.5787
39	4.21166	10.342	266.666	181.333	2973.79	6.9765
40	74.433	8.511	172.222	172.944	686.63	2.0519
41	74.433	122.5	179.2	325.666	703.615	2.0594
42	4.1626	14.479	312.777	196.44	3061.7	6.8969
43	9.581	8.136	171.05	171.055	722.223	2.0469
44	74.433	122.0	197.5	325.372	844.8	2.4091
45	5.4188	17.237	197.5	205	866.435	2.3576
46	74.433	121,60	234.9	325	1014.67	2.6038

Table.2: Description Data Of Steam Cycle For Dura Power Plant (Hashem and Murad 1998)

Pt	t (C <sup>0</sup> )	pressure (bar)	m kg/s	h kJ/kg	s kJ/kg.K
----	---------------------	----------------	--------	---------	-----------

1	535	133.4	135.95	3426	6.549
2	360.7	39.11	19.03	3124	6.645
3	361.9	40.45	115.1	3124	6.627
4	535	36.29	115.1	3528	7.253
5	374	11.13	4.837	3208	7.345
6	269.8	4.435	6.557	3004	7.387
7	164.1	1.603	5.548	2800	7.232
8	X=0.995	0.563	6.789	2639	7.52
9	X=0.922	0.068	91.38	2384	7.688
10	-----	0.068	91.38	161.7	0.553
11	38.6	0.068	105.5	161.6	0.554
12	38.8	15.57	105.5	163.7	0.552
13	45.1	-----	12.34	188.8	0.639
14	81.4	6.886	105.5	341.2	1.089
15	113.4	-----	5.548	475.6	1.456
16	110.4	6.396	105.5	463.5	1.421
17	147.4	4.435	135.95	620.9	1.815
18	150	160.4	135.95	641.8	1.825
19	157	-----	23.862	662.8	1.912
20	184.8	159.5	135.95	790.9	2.163
21	249	-----	19.03	1081	2.785
22	248	158.5	135.95	1077	2.748

Table.3: Exergy Analysis Summary Of South Baghdad Power Plant (Mathure et. Al. 2000)

No	Components	Exergy loss %	$\eta_{II}\%$
1	Boiler	56.8	Boiler-43.2
2	Turbine	7.4	Steam cycle- 74.76
3	Condenser and hot well	2.08	Overall efficiency-29.61 take to account
4	Pumps	-----	power use factor =0.917
5	Feed water heaters	-----	

Table.4: Exergy Analysis Summary Of Dura Power Plant (Hashem and Murad 1998)

No	Components	Exergy loss %	$\eta_{II}\%$
----	------------	---------------	---------------



1	Boiler	50.00	Boiler – 50.0
2	Turbine	4.17	Steam cycle-84.0
3	Condenser	2.05	Overall efficiency-42.0%
4	Feed water heating	1.45	
5	Feed water pump	0.105	
6	Mec.&generator	0.65	

Table.5: Entropy Method Analysis Summary Of South Baghdad Power Plant

No	Components	Irreversibility coefficient $\Omega_i$ %	$\eta$
1	Boiler	58.0	
2	Turbine	6.60	
3	Condenser and hot well	2.3	
4	Feed water heaters	4.8	
5	Mechanical	0.3	
6	Generator	0.4	Overall efficiency=27.6
7	total	72.4	

Table.6: Entropy Method Analysis Summary Of Dura Power Plant

No	Components	Irreversibility coefficient $\Omega_i$ %	$\eta$
1	Boiler	51.03	
2	Turbine	4.12	
3	Condenser	1.998	
4	Feed water heaters	1.6	
5	Mechanical	0.4	
6	Generator	0.4	Overall efficiency=40.2
7	total	59.8	

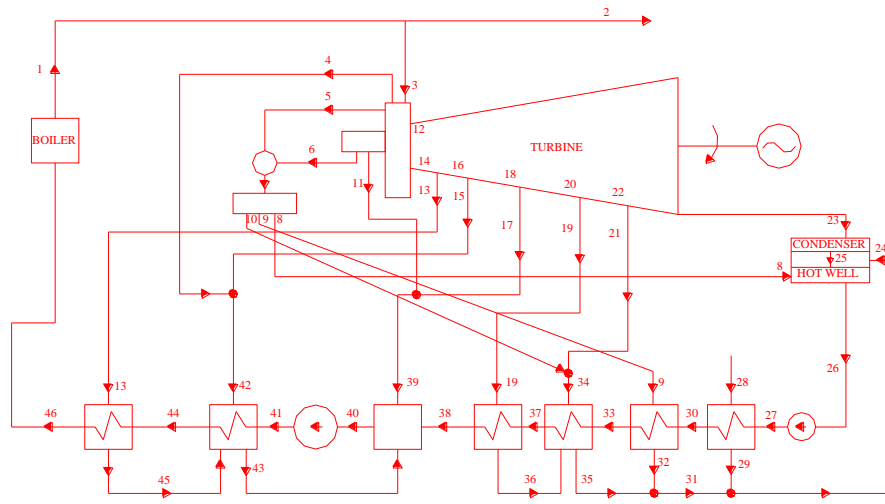

**Fig. 1: The Heat Cycle Of The Unit Of South Baghdad Power Plant**

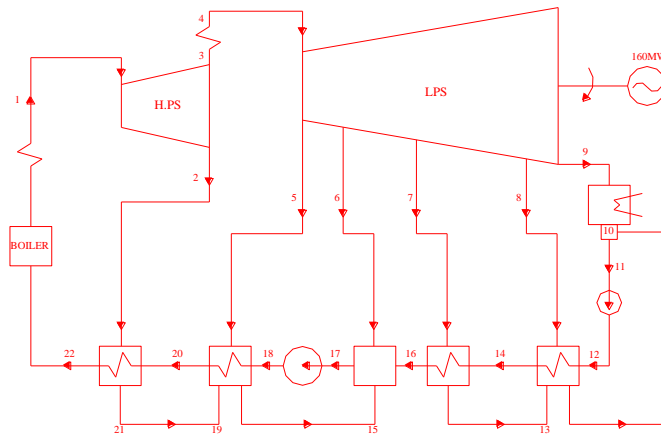

Fig.2: The Heat Cycle Of The Unit Of Dura Power Plant

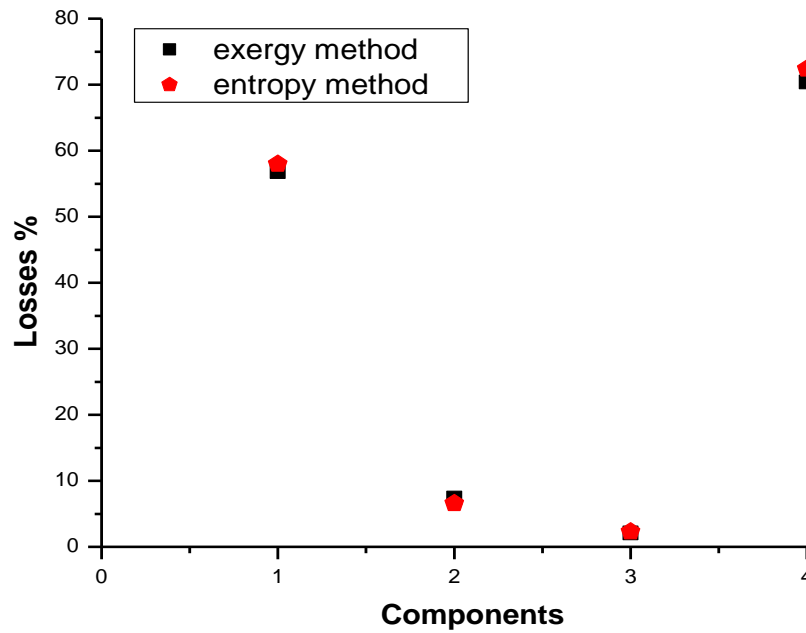
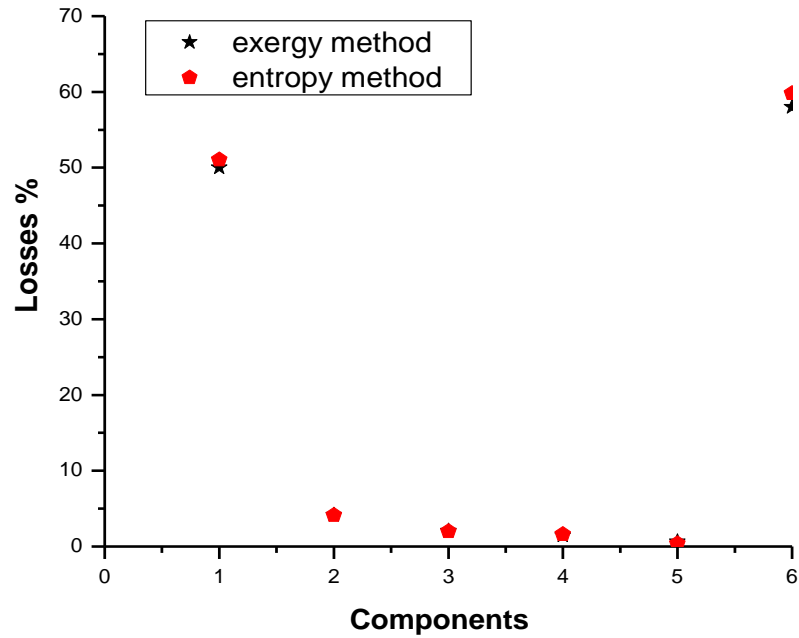

Fig3: Exergy And Entropy Method Analysis For South Baghdad Power Plant  
X-Axis:- 1- Boiler 2- Turbine 3- Condenser And Hot Well 4- Overall Plant



**Fig.4: Exergy And Entropy Method Analysis For Dura Power Plant**  
X-Axis: 1- Boiler 2- Turbine 3- Condenser 4- Feed Water Heaters  
5- Mec.& Gen. 6- Overall Plant