

Enhanced Chain-Cluster Based Mixed Routing Algorithm for Wireless Sensor Networks

Husam Kareem Farhan

Assistant Lecturer

Ministry of Education / Directorate of Baghdad Education (Karkh 3)

E-mail: husam_kf@yahoo.com

ABSTRACT

Energy efficiency is a significant aspect in designing robust routing protocols for wireless sensor networks (WSNs). A reliable routing protocol has to be energy efficient and adaptive to the network size. To achieve high energy conservation and data aggregation, there are two major techniques, clusters and chains. In clustering technique, sensor networks are often divided into non-overlapping subsets called clusters. In chain technique, sensor nodes will be connected with the closest two neighbors, starting with the farthest node from the base station till the closest node to the base station. Each technique has its own advantages and disadvantages which motivate some researchers to come up with a hybrid routing algorithm that combines the full advantages of both cluster and chain techniques such as CCM (Chain-Cluster based Mixed routing). In this paper, introduce a routing algorithm relying on CCM algorithm called (Enhanced Chain-Cluster based Mixed routing) algorithm E-CCM. Simulation results show that E-CCM algorithm improves the performance of CCM algorithm in terms of three performance metrics which are: energy consumption, network lifetime, and (FND and LND). MATLAB program is used to develop and test the simulation process in a computer with the following specifications: windows 7 (32-operating system), core i5, RAM 4 GB, hard 512 GB.

Keywords: wireless sensor networks, energy efficiency, cluster routing algorithm, chain routing algorithm.

الخوارزمية المحسنة سلسلة المجموعة على اساس التوجيه المختلط لشبكات الاستشعار اللاسلكية

حسام كريم فرحان

مدرس مساعد

وزارة التربية / المديرية العامة للتربية / بغداد / الكرخ 3

الخلاصة

كفاءة الطاقة هي جانب هام في تصميم بروتوكولات توجيه قوية لشبكات الاستشعار اللاسلكية (WSNs). بروتوكول التوجيه الموثوق يجب أن يكون كفوء في استخدام الطاقة ومتكيف مع حجم الشبكة. لتحقيق الحفاظ العالي على الطاقة وتجميع البيانات، يوجد اثنين من التقنيات الرئيسية: مجموعات وسلاسل. في تقنية التجميع، غالباً ما تنقسم شبكات الاستشعار إلى مجموعات فرعية غير متداخلة تسمى مجموعات. في أسلوب السلسلة، سيتم ربط عقد الاستشعار مع أقرب جارين، بدءاً من أبعد عقدة عن المحطة الأساسية حتى أقرب عقدة إلى المحطة الأساسية. كل تقنية لها مزايا وعيوب خاصة بها الأمر الذي حث بعض الباحثين إلى طرح خوارزمية التوجيه الهجينة التي تجمع بين المزايا الكاملة لكلا الطريقتين المجموعات والسلاسل مثل CCM (سلسلة-المجموعة على اساس التوجيه المختلط). في هذا البحث، نقدم خوارزمية توجيه بالاعتماد على خوارزمية CCM (الخوارزمية المحسنة سلسلة-المجموعة على اساس التوجيه المختلط) E-CCM. نتائج عملية المحاكاة تبين ان خوارزمية E-CCM تحسن من أداء خوارزمية CCM من حيث ثلاثة معايير للأداء وهي: استهلاك الطاقة، عمر الشبكة، و (FND and LND). تم استخدام برنامج MATLAB لتطوير واختبار عملية المحاكاة في حاسوب يحمل المواصفات التالية: ويندوز 7 (نظام التشغيل 32 بت)، كور i5، ذاكرة الوصول العشوائي 4 GB، القرص الصلب 512 GB.



1. INTRODUCTION

A wireless sensor network (WSNs) consists of number of sensor nodes that communicate wirelessly and have the ability to sense the surrounding environment including pressure, temperature, humidity and illumination **Oda, et al., 2014**. As WSNs are generally powered by small batteries, energy consumption is the critical aspect that faces the operation of WSNs which has prime effect on the network lifetime. Many researches have been focusing on developing routing algorithms that can decrease the energy consumption and consequently extend the network lifetime. The biggest share of the energy is consumed by data routing, particularly by data transmission which is proportional to the square of the distance between sender and receiver **Tang, et al., 2012**. Thus many algorithms have been proposed to decrease the distance of transmission which leads to decrease the energy consumption and eventually increase the network lifetime.

The earliest routing algorithm aimed to use the above strategy is Low Energy Adaptive Clustering hierarchy (LEACH) **Heinzelman, et al., 2000**. LEACH divides the network into small group and each group forms a cluster and elects one of the sensor nodes within the group to function as a cluster head. The head of each cluster aggregate their data received from other nodes and send it to the base station. This algorithm is the first hierarchical algorithm that proposed to maximize the network lifetime. Another routing algorithm has proposed as an improvement to LEACH which is Power Efficient Gathering in Sensor Information System (PEGASIS) **Lindsey, and Raghavendra, 2002**. PEGASIS utilize chain technique instead of clustering technique in order to achieve more energy conservation. Each node will connect to the two closest neighbors starting with the farthest node from the base station up to the closest node to the base station. In this paper, try to use a hybrid scheme that combines the cluster and chain technique. The proposed algorithm divides the network into multiple chains and works within two stages.

2. RELATED WORK

The emergence of LEACH and PEGASIS in the area of designing a hierarchical routing algorithms leads to many valuable researches that came up with different hierarchical routing algorithms. Moreover, the increasing interest in WSNs and ongoing development in its applications and techniques become the inspiration for the researchers' efforts in order to explore the details of applications, characteristics and communication mechanisms of WSNs. However, there are wide variety of WSNs hierarchical routing algorithm, it can be classified into three categorize which are cluster, chain and hybrid routing algorithms **Kareem, et al., 2014**. **Yu and Song, 2010** utilized chain technique to propose an algorithm which called EECB (Energy Efficient Chain Based Routing Protocol). EECB algorithm can solve the problem that happen when the sensor node are relatively distant from its closest neighbors.

Taking advantage of chain strategy, **Gao, et al., 2012** come up with a routing algorithm which designed with a predetermined job (transmission line monitoring system). The proposed algorithm, in addition to chain technique, it utilizes the Ant colony optimization method to create a reliable real-time monitoring algorithm. This algorithm is mainly divided into two stages. The first stage is routing establishment which includes three steps: preparation, building process, and local search mechanism. After finalizing the establishment process and specifying the optimum path, the second stage of the routing algorithm will start which involves data transmission. This algorithm has a great advantage that can effectively jump out of the local optimization and rapid access to superior solutions. Thus, this algorithm when compared with basic ant colony algorithms it will show is more appropriate for long-chain wireless sensor networks. On the other hand, it cannot fit with various applications except the transmission lines or the applications that

requires long chains of sensor nodes so it cannot be considered a general algorithm for different WSNs applications. **Mahajan, et al., 2013** introduced an algorithm called IECBSN (Improved Energy Efficient Chain Based Sensor Network) that adopts new factor for the process of selecting the chain head, this factor called selection value SV . It combines two parameters in an equation to calculate the SV value, which are the remaining energy for each individual node and the distance between each sensor node and the base station. Eq. (1) is used to calculate SV value for each node. The node that has the maximum SV will be chosen to operate as a chain leader. Moreover, IECBSN algorithm consists of four stages: network construction, chains formation, leader selection, and data transmission.

$$SV_i = E_{r(i)} \frac{1}{adist(ni, nBs)} \quad (1)$$

Where SV_i represents the factor that define the relationship between the residual energy and the distance to the base station for each node in the chain and $E_{r(i)}$ represents the residual energy of the node number i , while $adist(ni, nBs)$ stands for the distance between the node i and the base station.

Hong, and Han, 2014 put forward a routing algorithm that can accomplish a maximum lifetime for the network at the same time with a maximum number of alive nodes. The proposed algorithm of **Hong, and Han, 2014** is called Cost-Efficient Routing Protocol (CERP) on Wireless Sensor Networks. CERP basic idea is to make the lifetime of each single node within the network same with other nodes. Therefore, the entire network will be dead almost at the same time then it will assure a reliable operation when the network alive because almost all the nodes are alive. **Kareem, et al., 2014** proposed a new routing algorithm called Two Stage Chain Routing Protocol for Wireless Sensor Networks (TSCP) which is based on chain technique. TSCP algorithm is mainly compatible with WSNs which have grid topology. It divides the network into multiple chains and forwards the data using multi-hop communication.

Ahmed, et al., 2008 introduced a clustering routing algorithm that employed a new technique (decision tree) to select the cluster head node. The decision tree is based on four factors (the distance between the node and the center of the cluster, residual energy of the node, mobility of the node, and Vulnerability index. Authors of Assisted LEACH (A-LEACH) introduced a modified routing algorithm that depends on LEACH as a bench mark **Kumar, and Pal, 2013**. Since LEACH represents the first hierarchical routing algorithm that used clustering technique, A-LEACH and other related algorithms are fall in cluster category of hierarchical routing algorithms for wireless sensor networks. A-LEACH uses a modified strategy to minimize the energy dissipated by separating the tasks of data routing and aggregating. It presented an idea of assisted nodes that can help the cluster head nodes for multi-hop routing. Another improvement has been done based on LEACH algorithm when **Balavalad, et al., 2014** introduced their algorithm which is called Multipath-LEACH. It is dividing the network into cells and each cell has a cluster head. The cluster head nodes communicate with each other to forward their data to the base station using multipath strategy.

Unlike other routing algorithms, which aim mainly to extend the network lifetime regardless other factors, such as mobility, traffic, and end to end connection. A routing algorithm based on clustering technique has been introduced in **Velmani, and Kaarthick, 2015** which is called Velocity Energy-efficient and Link-aware Cluster-Tree (VELCT) scheme for data collection in WSNs. VELCT aims to be an efficient solution for coverage distance, traffic, delay, tree intensity, mobility, and end-to-end connection problems. VELCT creates a Data collection tree (DCT) depending on the cluster head (CH) location. The node that is responsible for data collection will not involve in sensing operation in the particular round. The main job for the data



collection node is to collect the data packets from the cluster head nodes and delivers them to the base station **Velmani, and Kaarthick, 2015**. The strategies that implemented in VELCT lead to reduce the traffic and end-to-end delay in cluster head in WSNs.

The last category of hierarchical routing algorithms is hybrid algorithm. Hybrid routing algorithm combine both cluster and chain techniques. A hybrid routing algorithm has been proposed such as CCM algorithm **Tang, et al., 2012**. It combines the advantage of chain technique which is low energy consumption at the same time utilize the fast data delivery advantage from the clustering mechanism. On the other hand, CCM algorithm has small drawback, which is the way of selecting the cluster head in the second stage. CCM uses the residual energy factor in order to decide upon which node is going to be the cluster head without considering the distance between the node and the base station. It is very normal that the node has maximum residual energy at the same time it is located very far from the base station which leads to high energy consumption during data transmission. Therefore, using only the residual energy to select the cluster head is neither efficient nor reliable. (REC+) **Taghikhaki, et al., 2013**. They proposed a Reliable and Energy-efficient Chain-cluster based routing protocol (REC+). REC+ aims to achieve the maximum reliability in a multi-hop communication by using the proper place for the Cluster Head (CH) and the best shape/size of the clusters without using any error controlling technique that can add extra overhead in terms of computation and communication. **Table 1** summarizes routing technique, performance metrics, and simulation tool used to evaluate each algorithm mentioned above.

3. E-CCM ALGORITHM

In this section, will present the proposed algorithm E-CCM (Enhanced Chain-Cluster Based Mixed Routing) which is a modified version of CCM algorithm that can improve the lifetime for the entire WSN by decreasing the energy consumption in each sensor node. E-CCM enhancement is in the second stage, specifically during the process of selecting the cluster head. As we mentioned before, CCM algorithm uses only the residual energy to decide upon which node is going to be the cluster head in the second stage without considering the distance between that node (cluster head) and the base station. Therefore, it is very normal to select a node with maximum residual energy but it is located very far from the base station which consequently consumes too much energy due to transmitting the aggregated data to the base station. In order to overcome this defect, E-CCM algorithm is presented. E-CCM algorithm utilizes another factor, which is the distance between the sensor node and the base station in addition to maximum residual energy to select the cluster head for the entire network. An equation is implemented, that combine both residual energy and distance from sensor nodes to the base station and then produce a factor called S_i , node with maximum S_i will be the cluster head in the second stage. E-CCM algorithm works within two stages, initialization stage and transmission stage. Moreover, it is mainly applicable for WSNs that use grid topology and the location of each sensor node is known to the base station.

3.1 Initialization Stage

Since the topology of the network is based on grid topology. Therefore each sensor node has an x and y coordinates. The E-CCM algorithm will divide the network into sub-sets based on the (y) coordinate of each sensor node. The nodes that have the same (y) coordinate will be on the same group. Then, one of the nodes in each group will be selected periodically to act as a head for other nodes in its own group. The periodic way of selection means that in the first sensing round, the first node in each group will be selected as group head, in the second sensing round, the second sensor node in each group will be the group head and so on. Assume that there is N

number of nodes distributed in $(n \times n)$ fashion, n represents the number of groups in the network and the number of nodes in each group. So that, the selection of the head is based on the output of the Eq. (1) where i represents the number of current sensing round and n is the number of sensor nodes in each group.

$$H_{node_id} = i \text{ mod } n \quad (2)$$

A description for the operation of first stage of E-CCM algorithm is summarized in the flowchart in **Fig. 1**.

3.2 Transmission Stage

This stage includes two steps, horizontal chains formation and vertical chain formation.

3.2.1 Multiple Chains Formation:

Each group of sensor nodes in the network will construct a horizontal chain. Each sensor node transmits its data to the closest neighbor that leads to the chain head which is selected in the first stage. When a node receives data from its neighbor, it aggregates the received data packet with its own data packet and then sends the aggregated packet to the closest neighbor that leads to the chain head and so on until all data are collected in the chain head.

3.2.2 Single cluster formation:

When all the sensed data packets are collected in the chain head nodes, the chain head nodes will form a cluster contains all head nodes. After forming the cluster, one of the sensor nodes that belong to the cluster will be selected to function as a cluster head and a main head for the entire network. The cluster head will be responsible for aggregating the data received from the chain head nodes and send the aggregated packet to the base station. The selection of cluster head node is based on two factors which are the residual energy of the sensor node and the distance between the node and the base station. Utilize Eq. (1) from **Mahajan, et al., 2013** in order to decide upon which node is going to be the cluster head in each sensing round.

The flowchart of the second stage is shown in **Fig. 2**.

3.3. Radio Model for Communication

The radio model utilized in the proposed algorithm is first order radio model which is used in wide variety research related to sensor networks such as **Lindsey, and Raghavendra, 2002, Mahajan, et al., 2013** and **Kareem, et al., 2014**. First order radio model assumptions are used in to determine the energy consumption due to data transmission and receiving. The transmission cost E_{TX} and receiving cost E_{RX} are calculated by the Eq. (3) and (4), respectively.

Energy consumption due to data transmission:

$$E_{TX}(kd) = E_{elec} \times k + E_{amp} \times k \times d^2 \quad (3)$$

Energy consumption due to data receiving:

$$E_{RX}(k) = E_{elec} \times k \quad (4)$$

Where k represents the size of data packet, d represents the distance between the sender and receiver. While E_{elec} stands for the energy the energy required to run the transmitter or the

receiver and E_{amp} is the energy consumed in order to run the amplifier. **Fig. 3** shows the first order radio model used in the proposed system **Kareem, et al., 2014**.

4. SIMULATION

MATLAB software is used to evaluate the performance of the E-CCM algorithm and compare its performance with the original CCM algorithm depends on three performance metrics: network lifetime, energy consumption, and first node and last node died (FND and LND).

4.1 Network Model

In simulation, assumed that the sensing area is a square matrix and sensor nodes are distributed evenly in a 2-dimensional array. 100 sensor nodes are distributed in (10×10) fashion 10 meters between each node and its closest neighbor.

- All sensor nodes are homogenous and have the same initial energy.
- The base station is located outside the sensing field at (50, 150) position, it is fixed and it is not energy constrained.
- All nodes have the ability to communicate directly with the base station.
- The energy consumed during the transmission of data packet depends on the size of the data packet and the distance between the node and the base station.
- The energy consumed due to data aggregation is 5nJ/bit/message **Lindsey, and Raghavendra, 2002**.

ZigBee network is designed for reliable wirelessly networked monitoring and control networks **Lee, et al., 2007**. Further, ZigBee offers a unique advantages for wireless application such as low cost, and low power consumption. Therefore, It is recommended to use ZigBee network with E-CCM algorithm. Since it is assumed that all sensor nodes have the ability to communicate with the base station, all sensor nodes must be a router type so that each node can communicate with all other nodes and can communicate to the base station directly. The coordinator node is interfaced to the base station. **Fig. 4** shows the sensor nodes deployment in the sensor field and the location of the base station with respect to the sensor network.

4.2 Simulation Parameters:

Some parameters used to simulate the E-CCM algorithm and compare its behavior with CCM algorithm. It is worth mentioning that the sensing field is assumed to be a square field with 100m×100m area. The sensor nodes are assumed to be stationary and their locations are known to the base station. The number of sensor nodes and the distance between each node and its closest neighbor should be specified before starting the simulation, for example 100-stationar sensor nodes are placed in the sensing area with a fixed distance 10 meter between each node and its closest neighbor. **Table 2** shows more details about the simulation parameters used in the simulation.

5. RESULTS AND ANALYSIS:

In this section, will show and analyze the simulation results in order to highlight the advantages of E-CCM algorithm in comparison with CCM algorithm using three performance metrics: Network life time, Energy consumption, and First node and Last node died (FND and LND).

5.1 Network Lifetime:

The period of time from the deployment of sensor nodes till the network considered as non-functional is defined as network lifetime **Kannan, and Paramasivan, 2014**. The moment that the

network considered as non-functional is user defined. In other words, it is based on the application of WSN. Therefore, it can be the moment when first node dies, the moment when specific percentage of sensor nodes die or the moment when all sensor nodes in the network dies. In simulation, will consider the lifetime of the network ends when all sensor nodes in the network die. **Fig. 5** shows the performance comparison of E-CCM algorithm and CCM algorithm based on the network lifetime.

Eq. (5) is used to determine the improvement of E-CCM algorithm over CCM algorithm. This equation is generally used to calculate the percentage of increase for different applications.

$$POI = \frac{\text{Second Value} - \text{First value}}{\text{First value}} \times 100 \% \quad (5)$$

Where POI represents the percentage of increase and in this performance metric it represents the percentage of improvement in network life time. First value represents the last sensing round when the sensor network was alive using CCM algorithm. Second value represents the last sensing round when the sensor network was alive using E-CCM algorithm. It is clear from **Fig. 4** and **Table 2** that E-CCM algorithm outperforms CCM algorithm in term of network lifetime. Implementing Eq. (5) show that E-CCM algorithm has an improvement about 14% over CCM algorithm. The reason is that when include the distance factor along with the remaining energy in each node to select the cluster head, it gives an advantage which consequently extends the lifetime for the entire network.

5.2 Energy Consumption:

Three factors are considered to be responsible for consuming the energy during data routing which are: data send, data receive and data aggregate. Using equation 1 and 2 to calculate the energy cost of data send and receive, considering the same assumption used in **Lindsey, and Raghavendra, 2002** to calculate energy cost for data aggregation. **Fig. 6** shows the amount of energy consumption in each algorithm versus sensing rounds.

From **Fig. 5**, it can be clearly seen that the amount of energy consumption during the network lifetime of E-CCM algorithm is less in comparison with CCM algorithm. In other words, E-CCM algorithm outperforms CCM algorithm in term of energy conservation. Once again, adding the distance factor to select the cluster head resulted in conserving more energy during the network lifetime.

5.3 FND and LND (First Node and Last Node Died):

In order to ensure the robustness and reliability of the routing algorithm, have to examine the performance of the network using different performance metrics. In this section, will compare the performance of E-CCM algorithm and CCM algorithms when first node in the network dies FND and when the last node in the network dies LND **Chen, and Zhao, 2005**.

From **Table 3** and **Fig. 7**, can see that E-CCM algorithm outperforms CCM algorithm in terms of FND and LND. Moreover, the results of utilizing Eq. (5) show that E-CCM algorithm achieve an improvement over CCM algorithm in about 16% and 14% when first node died and last node died respectively. Therefore, E-CCM algorithm shows a remarkable performance in compare with CCM algorithm in terms of FND and LND.

6. CONCLUSION

In this paper, proposed an energy efficient routing algorithm that minimize the energy consumption of WSN and consequently extend the network lifetime. The proposed algorithm E-CCM divides the sensor nodes into multiple groups and the form a chain from each group. After



chain formation, one node from each chain will function as chain head periodically. All sensor nodes in each chain will send their data to the head of their chain using multi-hop communication. After that, all chain head nodes will form a cluster and select a cluster head based on the remaining energy of each node and the distance between the node and base station. The cluster head node is responsible for receiving the data from cluster members, aggregate the received data with its own data and send the aggregated data packet to the base station. MATLAB program is used as simulation tool in order to evaluate the performance of E-CCM algorithm and compare it with the previous work. Moreover, the evaluation process is conducted based on three performance metrics which are network lifetime, energy consumption and (FND and LND). Utilizing simulation results in Eq. (5) show that E-CCM algorithm could achieve an improvement in the network lifetime in about 14% in comparison with CCM algorithm. Furthermore, E-CCM algorithm shows a significant improvement in term of FND (first node died) in about 16% in comparison with CCM algorithm. Therefore, combining the distance factor with the remaining energy during the selection of cluster head led to a remarkable impact on the entire networks' lifetime and the energy conservation in wireless sensor network.

REFERENCES

- Oda, H. Hisamatsu, H and Noborio, H., 2012, *Proposal and Evaluation of an Information Dissemination Method Based on Flooding for Energy Efficiency in Wireless Sensor Networks*, Journal of Advances in Computer Networks, Vol. 2.
- Tang, F., You, I., Guo, S., Guo, M., and Ma, Y. 2012, *A chain-cluster based routing algorithm for wireless sensor networks*, journal of intelligent manufacturing, Vol. 23, No. 4, PP.1305-1313.
- Heinzelman, W. R., Chandrakasan, A., and Balakrishnan, H., 2000, *Energy-efficient communication protocol for wireless microsensor networks*, In System sciences, Proceedings of the 33rd annual Hawaii international conference on, IEEE , Vol. 2, pp. 10.
- Lindsey, S., and Raghavendra, C. S., 2002, *PEGASIS: Power-efficient gathering in sensor information systems*, In Aerospace conference proceedings, IEEE, Vol. 3, PP. 1125-1130.
- Kareem, H., Hashim, S., Sali, A., and Subramaniam, S., 2014, *A Survey of State of the Art: Hierarchical Routing Algorithms for Wireless Sensor Networks*, Journal of Theoretical & Applied Information Technology, Vol. 62, No. 3, PP. 769-781.
- Yu, Y., and Song, Y., 2010, *An Energy-efficient Chain-based Routing Protocol in Wireless Sensor Network*, In Computer Application and System Modeling (ICCASM), International Conference on, IEEE, Vol. 11, PP. 486-489.
- Ahmed, G., Khan, N. M., Khalid, Z., and Ramer, R., 2008, *Cluster head selection using decision trees for wireless sensor networks*, In Intelligent Sensors, Sensor Networks and Information Processing, ISSNIP International Conference on, IEEE, Vol., PP. 173-178.
- Mahajan, S., Malhotra, J., and Sharma, S., 2013, *Improved enhanced chain based energy efficient wireless sensor network*, Wireless Sensor Network, Vol. 5 No. 4, PP. 84-89.



- Hong, S., and Han, K. H., 2014, *Cost-efficient routing protocol (CERP) on wireless sensor networks*, *Wireless Personal Communications*, Vol. 79, No. 4, PP. 2517-2530.
- Kareem, H., Hashim, S., Subramaniam, and Sali, A., 2014, *Energy Efficient Two Stage Chain Routing Protocol (TSCP) for Wireless Sensor Networks*, *Journal of Theoretical and Applied Information Technology*, Vol. 59, No. 2, PP. 442-450.
- Gao, J., Wei, L., Zhu, Y., and Li, L., 2012, *Routing Optimization Based on Ant Colony Algorithm for Wireless Sensor Networks with Long-Chain Structure*, In *Internet of Things*, Springer Berlin Heidelberg, PP.91-97.
- Kumar, S. V., and Pal, A., 2013, *Assisted-leach (a-leach) Energy Efficient Routing Protocol for Wireless Sensor Networks*, *International Journal of Computer and Communication Engineering*, Vol. 2, No. 4, PP. 420-424.
- Balavalad, K. B., Katageri, A. C., B. M. Biradar, B. M., Chavan, D., and Angadi, B. M., 2014, *Multipath-LEACH an Energy Efficient Routing Algorithm for Wireless Sensor Network*, *Journal of Advances in Computer Networks*, Vol. 2, No. 3, PP. 229-232.
- Velmani, R., and Kaarthick, B., 2015, *An Efficient Cluster-Tree Based Data Collection Scheme for Large Mobile Wireless Sensor Networks*. *Sensors Journal, IEEE*, Vol. 15, No. 4, PP. 2377-2390.
- Taghikhaki, Z., Meratnia, N., and Havinga, P. J., 2013, *A Reliable and Energy-efficient Chain-cluster Based Routing Protocol for Wireless Sensor Networks*, In *Intelligent Sensors, Sensor Networks and Information Processing*, IEEE Eighth International Conference on, PP. 248-253.
- Lee, J. S., Su, Y. W., and Shen, C. C., 2007, *A comparative study of wireless protocols: Bluetooth, UWB, ZigBee, and Wi-Fi*. In *Industrial Electronics Society, IECON, IEEE 33rd Annual Conference on*, PP. 46-51.
- Kannan, K. N., and Paramasivan, B., 2014, *Enhancing Energy Efficiency in Wireless Sensor Networks Using Optimal Gradient Routing Protocol*, *International Journal of Computer and Communication Engineering*, Vol. 3, No. 6, PP. 408-412.
- Chen, Y., and Zhao, Q., 2005, *On the lifetime of wireless sensor networks*, *Communications Letters, IEEE*, Vol. 9, No. 11, PP. 976-978.

NOMENCLATURE

Symbol	Description	Unit
N	number of sensor nodes of the entire network.	Unit less
N	number of the sensor nodes groups and number of sensor nodes in each group. (assumed equal).	Unit less
I	number of the current sensing round.	Unit less
S_i	the factor that define the relationship between the residual energy and the distance to the base station for each sensor node.	Joule/meter
$E_{r(i)}$	the residual energy of the node number i .	Joule
$adist(n_i, nBs)$	the distance between the node i and the base station.	Meter
$E_{TX}(kd)$	energy consumption due to transmission of data packets.	Joule
$E_{RX}(k)$	energy consumption due to receiving data packets.	Joule
K	size of data packet.	Bit
D	the distance between the sender and the receiver.	Meter
E_{elec}	the energy required to run the transmitter or the receiver.	nJ/bit
E_{amp}	the energy consumed in order to run the amplifier.	PJ/bit/m ²
POI	percentage of increase	Unit less
FND	first node died in the network	Unit less
LND	last node died in the network	Unit less

Table 1. Simulation tool, performance metric(s) and routing technique used in each algorithm.

Algorithm name	Simulation tool	Performance metric(s)	Routing technique
Leach	MATLAB	Network lifetime	Cluster
Pegasis	C language	Network lifetime	Chain
EECB	Not mentioned	Network lifetime	Chain
Gao, et al.	MATLAB	Find an optimal path	Chain
CERP	Not mentioned	Energy deviation for each mode in the sensor network	Chain
TSCP	MATLAB	Load Balancing, Network Lifetime and stability interval, energy consumption	Chain
Ahmed, et al.	MATLAB	Network lifetime	Cluster
A-LEACH	C language	Network lifetime and energy consumption	Cluster
Multipath-LEACH	MATLAB	Network lifetime and energy consumption	Cluster
VELCT	NS-2	Energy consumption, throughput, end-to-end delay, and network lifetime	Cluster
CCM	SWANS	Energy consumption, transmission delay, and Energy \times Delay	Hybrid
REC+	Not mentioned	Network lifetime, Energy \times Delay, Energy consumption, Delay, End-to-End reliability	Hybrid

**Table 2.** Simulation Parameters.

<i>Parameter</i>	<i>Value</i>
Area of the sensing field	$(100 \times 100) \text{ m}^2$
Base station position	(50,150)
Number of sensor nodes	100
Behavior of the nodes	Stationary
Network type	Assumed to be ZigBee
Initial energy of each sensor node	0.5 Joule
E_{elec}	50 nJ/bit
E_{amp}	100 PJ/bit/m ²
Size of data packet	2000 bit

Table 3. FND and LND.

Metric	E-CCM (Sensing Rounds)	CCM (Sensing Rounds)
FND	1652	1420
LND	2142	1877

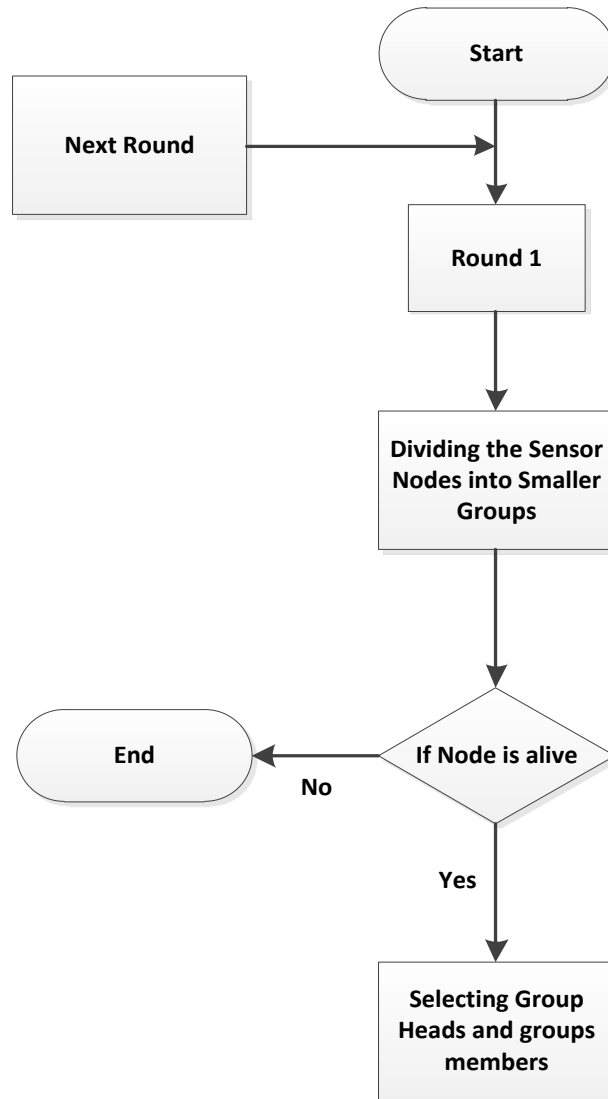

Figure 1. Flowchart of the initializing stage of E-CCM algorithm.

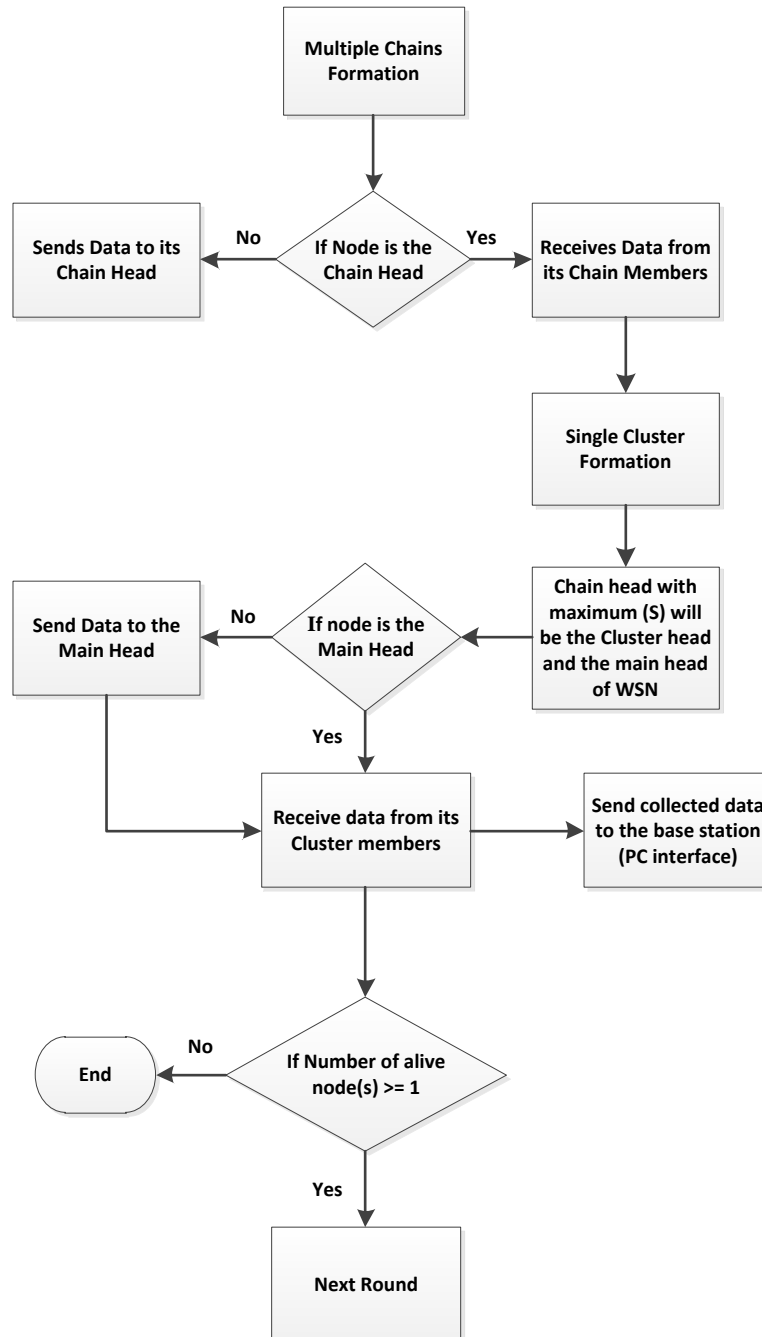

Figure 2. Flowchart of the Transmission stage of E-CCM algorithm.

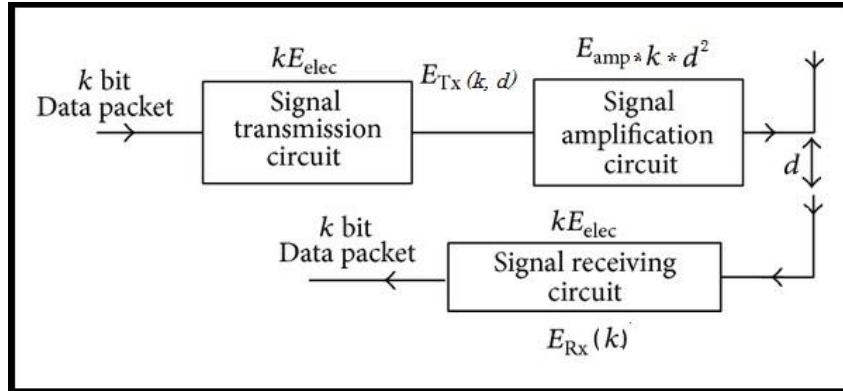

Figure 3. Radio model used in the system.

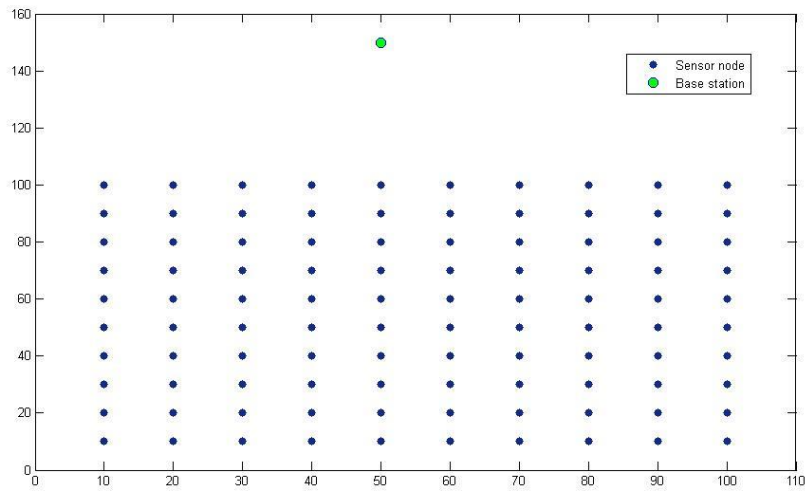

Figure 4. Network architecture.

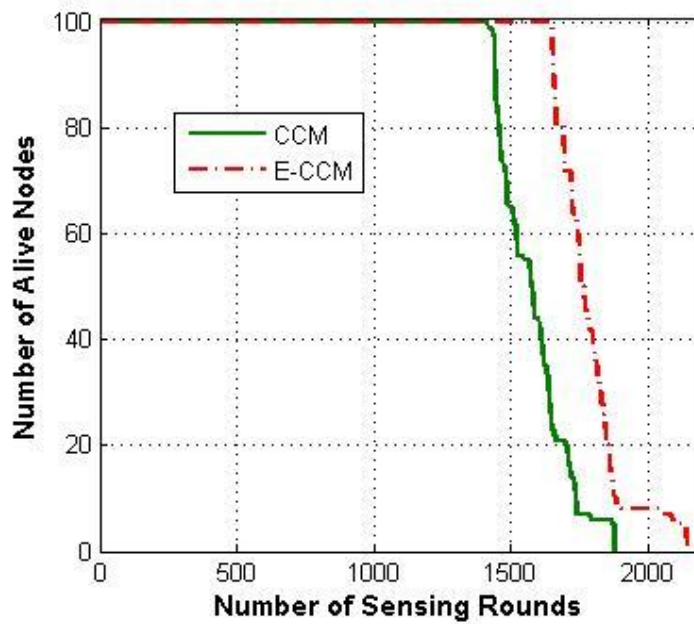

Figure 5. Network Lifetime.

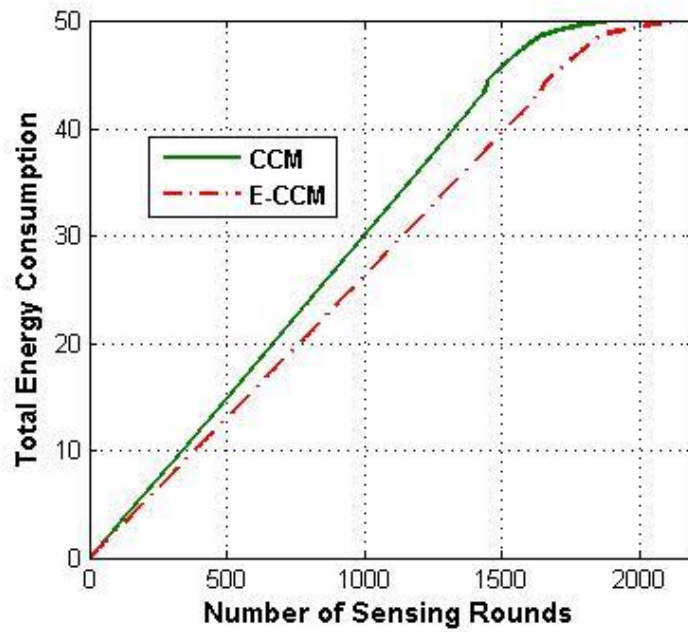

Figure 6. Energy Consumption.

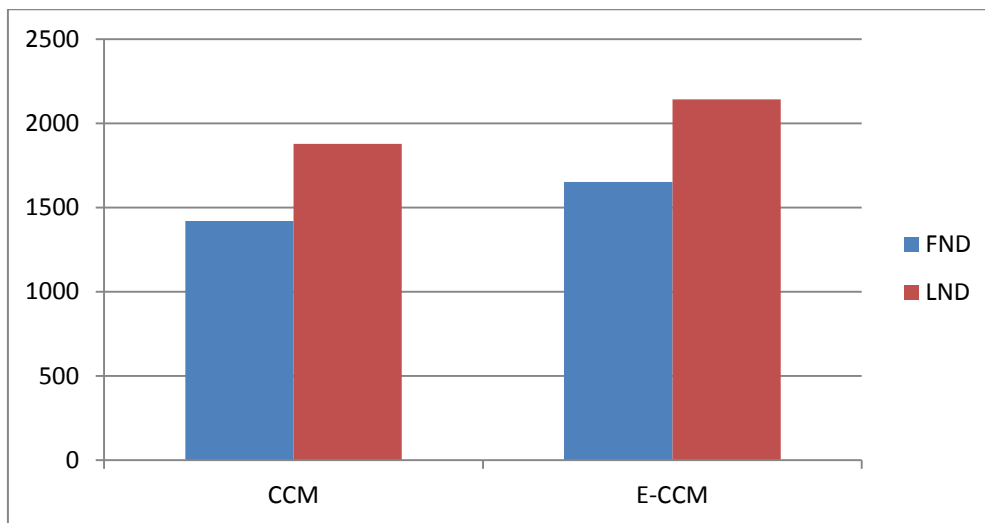

Figure 7. FND and LND.