

## Improve the Performance of PID Controller by Two Algorithms for Controlling the DC Servo Motor

Asst. Lect. Noor Safaa Abdul-Jaleel  
Department of Electrical Engineering  
College of Engineering  
Al-Mustansyria University  
E-mail: [mail\\_nsl@yahoo.com](mailto:mail_nsl@yahoo.com)

### ABSTRACT

The paper uses the Direct Synthesis (DS) method for tuning the Proportional Integral Derivative (PID) controller for controlling the DC servo motor. Two algorithms are presented for enhancing the performance of the suggested PID controller. These algorithms are Back-Propagation Neural Network and Particle Swarm Optimization (PSO). The performance and characteristics of DC servo motor are explained. The simulation results that obtained by using Matlab program show that the steady state error is eliminated with shorter adjusted time when using these algorithms with PID controller. A comparative between the two algorithms are described in this paper to show their effectiveness, which is found that the PSO algorithm gives better results to improve the PID controller for controlling the DC servo motor compared to the neural network algorithm.

**Keywords:** - DC servo motor, direct synthesis, PID controller, neural network, particle swarm optimization (PSO).

تحسين اداء المسيطر التناسقي التكاملي التفاضلي باستخدام خوارزميتان للسيطرة على محرك تيار مستمر

م.م. نور صفاء عبد الجليل  
قسم هندسة الكهرباء  
كلية الهندسة / الجامعة المستنصرية

### الخلاصة

يقدم هذا البحث طريقة (DS) في تحديد معاملات المسيطر التناسقي التكاملي التفاضلي للسيطرة على محرك تيار مستمر. حيث استخدمت خوارزميتان لتحسين اداء المسيطر التناسقي التكاملي التفاضلي هما: وحدة تحكم الشبكة العصبية وخوارزمية الحركة المثلى لاسراب الجسيمات. محرك التيار المستمر والخوارزميتان تم تمثيلهما باستخدام برنامج المحاكاة (Matlab), وقد تمت المقارنة بين الخوارزميتين لبيان تأثيرهم على المسيطر المقترح حيث اظهرت نتائج المحاكاة ان خوارزمية الحركة المثلى لاسراب الجسيمات اعطت نتائج افضل لتحسين اداء المسيطر المستخدم من حيث سرعة الاستجابة للسيطرة على محرك التيار المستمر بالمقارنة مع خوارزمية الشبكة العصبية.

- الكلمات الرئيسية: محرك تيار مستمر, التوليف المباشر, المسيطر التناسقي التكاملي التفاضلي, الشبكة العصبية, الحركة المثلى لاسراب الجسيمات.

## 1. INTRODUCTION

Direct current (DC) servo motor is essential in modern industries. Servo motors are not a specific group of motor, but the term servo motor is often used to refer to a motor suitable for use in a closed loop control system. Servo motors are used in different applications in industrial tools, control systems of computers, robotics, ect., **Dipraj, and Dr. A. K., 2012**. A lot of control methods are used with the servo motors, **Akar, et ai., 2012**, like Proportional Integral Derivative (PID) which is usually used in various systems because of their simple structure with high performance, **Akar, and Cankaya, 2007**. So, to implement a PID controller, proportional gain ( $k_P$ ), Integral gain ( $k_I$ ) and Derivative gain ( $k_D$ ) must be solved. Many approaches have been suggested to solve these parameters; **Kumar, and Babu, 2014**, presents the PID tuning by Ziegler-Nichols (ZN) method to control the position of servo motor which is lead to satisfy the closed-loop response. **Bindu, and Namboothiripad, 2013**, presents fast tuning method based on genetic algorithm to derive the parameters of PID controller for the desired system. **Venugopal, et al., 2013**, Applied the soft computing technique of the fuzzy logic for tuning the PID controller to get the best dynamic and static performance at the output. **Shalal, et al., 2013**, presents an optimal design of PID controllers based on the minimization of an integral standard; in this paper DS method is used to solve the parameter of the PID controller. Also, the study present the formal procedure to improve the PID controller for a DC servo motor, where the optimal parameter of the PID controller is determine by using DS method. PSO and neural network algorithms have been used to improve the PID controller to get the high quality response compared with the original system.

This paper organized as follows. Section (2) explains the mathematical model of DC servo motor. Section (3) describes the method of PID controller tuning by DS method. Section (4) describes the Neural Network and PSO algorithms respectively. Experimental results in section (5). Finally, conclusion is summarized in section (6).

## 2. MATHEMATICAL MODEL OF DC SERVO MOTOR

The Direct Current (DC) servo motor that has been used in this paper is shown in **Fig. 1** and **Fig. 2** represent the block diagram of DC servo motor, where this motor is a 25 V with no load speed of 4050 rpm.

The differential equations of the armature DC servo motor connection can be derived as the equations below, **Dipraj, and Dr. A. K., 2012**:

$$V_a(t) = R_a i_a + L_a \frac{di_a}{dt} + V_b \quad (1)$$

Where the equation of torque is:

$$T_m = J \frac{d\omega_m}{dt} + B\omega_m(t) \quad (2)$$

$$V_a = K_b \cdot \omega_m(t) \quad (3)$$

Where  $K_b$  is constant. To create the block diagram of the system, the initial conditions and Laplace transform is implemented as the equations below:



$$V_a(s) = R_a i_a(s) + sL_a i_a(s) V_a(s) \quad (4)$$

$$T_m(s) = sJ\omega_m(s) + B\omega_m(s) \quad (5)$$

$$V_a = K_a\omega_m(s) \quad (6)$$

### 3. PID TUNING BY DIRECT SYNTHESIS METHOD

Direct Synthesis (DS) method is based on the required form for the system's response, and then finding controller parameters to get that response.

If we consider  $\left(\frac{y}{r}\right)$  is the desired output response,  $G_c$  is the PID controller and  $G_p$  is a model of the process. The closed loop transfer function is:

$$\frac{y}{r} = \frac{G_c(s)G_p(s)}{1 + G_c(s)G_p(s)} \quad (7)$$

Rearranging and solving  $G_c(s)$  to get the equation for the feedback controller:

$$G_c(s) = \frac{1}{G_p(s)} \left[ \frac{\left(\frac{y}{r}\right)}{1 - \left(\frac{y}{r}\right)} \right] \quad (8)$$

Let  $\left(\frac{y}{r}\right) = \frac{1}{(\tau_c s + 1)}$ , Where  $\tau_c$  is the time constant. Replacing the  $(y/r)$  by  $\frac{1}{(\tau_c s + 1)}$

The Eq. (9) becomes:

$$G_c(s) = \frac{1}{G_p(s)} \left[ \frac{\frac{1}{(\tau_c s + 1)}}{1 - \frac{1}{(\tau_c s + 1)}} \right] \quad (9)$$

$$G_c(s) = \frac{1}{G_p(s)} \frac{1}{\tau_c s} \quad (10)$$

$$\text{Let } G_p(s) = \frac{K_0}{(\tau_1 s + 1)(\tau_2 s + 1)}$$

$$\begin{aligned} G_c(s) &= \frac{(\tau_1 s + 1)(\tau_2 s + 1)}{K_0} \frac{1}{\tau_c s} \\ &= \frac{(\tau_1 + \tau_2)}{K_0 \tau_c} \left[ 1 + \frac{1}{(\tau_1 + \tau_2)s} + \frac{\tau_1 \tau_2}{(\tau_1 + \tau_2)s} \right] \end{aligned} \quad (11)$$

This is PID controller with:

$$K_p = \frac{(\tau_1 + \tau_2)}{K_0 \tau_c} \quad (12)$$

$$\tau_I = (\tau_1 + \tau_2) \quad (13)$$

$$\tau_D = \frac{\tau_1 \tau_2}{(\tau_1 + \tau_2)} \quad (14)$$

**Fig. 3** show the block diagram of DC servo motor with PID controller

#### 4. THE ALGORITHMS FOR IMPROVING THE PID CONTROLLER

Two algorithms are presented to improve the solution quality of the PID controller with finer tuning, Neural Network (NN) algorithm and Particle Swarm Optimization (PSO) algorithm. The two algorithms can be described as follows:

##### 4.1 Neural Network Algorithm

The artificial neural network is a system of processing information and it has some features like biological neural network, **Kumar, and Singh, 2013**. For a new control suggestion and the techniques in the control field, the artificial neural network as a new type of getting the information, characterization and processing which are the reason of process control interest. Intelligent control systems can design a method that can rating any signal for obtaining required response without assuming signal conduct, **Al-Ghasem, and Ussaleh, 2012**. Also, neural network has ability to approximate the nonlinear function relation with more suitable learning techniques; therefore it can be applied on new complex process modeling, **Louren, and Jinling, 2011**. Back propagation (BP) neural network considered as one of the forward feedback networks, and it's the most popular networks used. The neural network can classify by three sections:

- 1- The input layer: the input units which take the information to be generalized through the network, where the information from the input will be pass during the network and an output product.
- 2- The hidden units take the input from the input layer, where the hidden unit jointly from the hidden layer, every unit in the input layer is connected to every unit of the hidden layer.
- 3-The output layer: the output units which command the group assigned through the network. The output units form the output layer. Every unit in the hidden layer is connected to every unit in the output layer. The weighted sum of the output from the hidden units shapes the input to every output unit, **Al-Ghasem, and Ussaleh, 2012**.

In this paper BP neural network is used to adjust the parameters of PID controller. **Fig. 4** explains the structure of BP neural network. From **Fig. 4**, BP neural network consist of three layers: one input layer, one hidden layer and one output layer with three input and three output variables. The input variables of the structure represented by:  $r(k)$  which is the reference response,  $y(k)$  is the output of the system, and the error between them represented by  $e(k)$ . The input of the hidden neurons of the hidden layer can be written as:

$$\text{net}_j^2 = \sum_{n=0}^x w_{jn}^2 * I_n^1 \quad (15)$$

$$\text{net}_i^2 = \sum_{n=0}^x w_{is}^2 * I_s^1 \quad (16)$$

Where,  $\text{net}_j^2$  and  $\text{net}_i^2$  are the input of the hidden layer, when  $w_{jn}^2$  and  $w_{is}^2$  are the weights of the hidden layer,  $I_n^1$  and  $I_s^1$  is the output of the  $n^{\text{th}}$  and  $s^{\text{th}}$  input of the input layer,  $n$  and  $s$  represent the number of input layers. The output layer can be written as:

$$\begin{cases} o_1(k) = K_p \\ o_2(k) = K_i \\ o_3(k) = K_d \end{cases} \quad (17)$$

#### 4. 1. 2 Pid controller based on back propagation-neural network

Substitute the conventional PID controller by using BP-neural network PID controller to reduce the error between the output of the system and prospective values. **Fig. 5** shows that the controller has two parts: the ordinary PID controller and BP neural network, this structure called neural network-PID controller. PID controller controls the DC servo motor directly, so the parameters of PID controller:  $K_p$ ,  $K_i$  and  $K_d$  are adjustable online; to obtain a good performance, the BP-neural network adjust the parameters of PID controller based on the operational situation of the system, that will make the adjustable parameters of the PID controller and the output of neurons are identical.

#### 4.2 PSO Algorithm

The other algorithm is Particle Swarm Optimaization (PSO). PSO algorithm was improved by Kenndy and Eberhart, which is taken from a social behavior of bird and fish teaching, and has been established to be a robust in solving nonlinear optimaization problems, **Rastogi**, and **Tiwari**, 2013. The advantage of PSO include the ease of implementation. It can be used to determine a various problems. PSO technique manage search using a population of a particles. Each one of this particle represents a elect solution to the problem, **Patel**, and **Parikh**, 2014. In this system, these particles change their positions by flying toward a potential place in a several dimensions search space and shares public information between particles.

The number of the particles ( $n$ ) is 30, and the number of the iterations ( $i$ ) is 10 Let the  $n^{\text{th}}$  particle be represented by  $x_n = (x_{n1}, x_{n2}, x_{n3}, \dots, x_{nj})$ , where  $j$  is

dimensional space = 3. The best previous position of the  $n$ th particle is  $pbest_n = (pbest_{n1}, pbest_{n2}, \dots, pbest_{nj})$ , and  $gbest_n$  is the global best position of the swarm of these particles and the velocity of the particle  $n$  is  $v_n = (v_{n1}, v_{n2}, v_{n3}, \dots, v_{nj})$ . The velocity and position of each particle are updated as the following equations:

$$v_{nj}(i+1) = w * v_{nj}(i) + c1 * rand * (pbest_{nj} - x_{nj}(i)) + c2 * rand * (gbest_n - x_{nj}(i)) \quad (18)$$

$$x_{nj}(i+1) = x_{nj}(i) + v_{nj}(k+1) \quad (19)$$

Where  $c1$  and  $c2$  are acceleration constants and  $w$  is weighting function. The fitness equation of the PSO algorithm is:

$$fitness = 0 * ones(n, bird\ step) \quad (20)$$

Where maximum numbers of bird steps = 50. The procedure of PSO algorithm is as follows:

- 1- Create initial value of particles with random positions and velocities within dimensions search space.
- 2- Determine the value of the fitness function of each particle.
- 3- The fitness function of each particle was compared with local-best, if the solution is better than its local-best then the change its local-best by solution.
- 4- Compare the fitness of these particles with global-best, if the fitness of these particle is better than global-best then change its global-best by this solution.
- 5- Find the new position and velocity for all the swarm elements.
- 6- Iterate steps until a stopping criterion is done.

**Fig. 6** describe the flow chart of the pso algorithm.

#### 4. 2. 1 Pid controller based on PSO algorithm

The PSO algorithm was applied to obtain the parameters of PID controller ( $K_p$ ,  $K_i$  and  $K_d$ ) to acquire a good performance of the output response for the controller system. In this algorithm the search space of this particles has three dimensional space. **Fig. 7** shows the block diagram of the PSO-PID controller of the system, where the controller consist of two phases: the conventional PID controller and PSO. The parameters of PID controller are adjustable online to get the optimal values that achieved a better performance.

## 6. SIMULATIONS AND RESULTS

This section shows the output response of DC servo motor transfer function without and with (PID) controller in **Fig. 8**, and **Fig. 9** respectively. The PID controller is improved by two algorithms: Neural Network and PSO. To show the effectiveness of these algorithms, a comparison of them is made with basic control system. **Fig. 10**, and **Fig. 11**, and **Fig. 12** shows the comparison of control system with and without Neural Network method, the comparison of control system with and without PSO method and the comparison of control system without and with these methods respectively.



The results shows the output response with (PSO) and (NN) methods improve the quality solution of PID controller with zero overshoot but the method of PSO gives the better results and good performance compared with the neural network.

## 6. CONCLUSION

Two algorithms are presented for improving the PID controller. The response of the system with the controller is oscillatory with little overshoot, so to avoid this case back propagation neural network algorithm and PSO algorithm are designed to give the high quality for the required response. The two algorithms gives the fast and smooth output response compared with the present controller with zero overshoot, but PSO algorithm give the better performance compared to the neural network algorithm.

## REFERENCES

- Akar, M., and Cankaya, I., 2007, *The Design of Real-Time PID Controller based on Lab view for DC Servo Motor*, National Technique Education Engineering and Education Science Young Researches Symposium in Turkish, pp. 76-179.
- Akar, M., and Hekim, M., and Temiz, I., and Dogan, Z., 2012, *The Speed and Torque Control of Direct Current Servo Motors by using Cascade Fuzzy PI Controller*, Electrical Review, ISSN 0033-2097, R. 88, NR. 5b.
- Al-Ghasem, A., and Ussaleh, N., 2012, *Air Conditioner Control using Neural Network and PID Controller*, IEEE 8<sup>th</sup> International Symposium on Mechatronics and its Applications (ISMA), pp. 1-5.
- Bindu, and Namboothiripad, M. K., 2013, *Tuning of PID Controller for DC Servo Motor using Genetic Algorithm*, International Journal of Emerging Technology and Advanced Engineering, vol. 2, Issue 3.
- Dipraj, and Pandey, Dr. A. K., 2012, *Speed Control of D. C. Servo Motor by Fuzzy Controller*, International Journal of Scientific and Technology Research, vol. 1, pp. 2277-8616.
- Kumar, P. R., and Babu, V. N., 2014, *Position Control of Servo Systems using PID Controller Tuning with Soft Computing Optimization Technique*, IEJT Journal of Process Control, vol. 3, Issue 11.
- Kumar, P., and Singh, K. P., 2013, *Comparative Analysis of Air Conditioning system using PID Controller and Neural Network Controller*, International Journal of Scientific and Research Publication, Vol. 3, Issue 8.
- Luoren, L., and Jinling, L., 2011, *Research of PID Control Algorithm Based on Neural Network*, Elsevier, vol. 13, pp. 6988-6993.
- Patel, A., and Parikh, K., 2014, *Speed Control of DC Motor using PSO Tuned PI Controller*, IOSR Journal of Electrical and Electronics Engineering, vol. 9, Issue 2, pp. 04-08.



- Rastogi, A., and Tiwari, P., 2013, *Optimal Tuning of Fractional Order PID Controller for DC Motor Speed Control using Particle Swarm Optimization*, International Journal and Soft Computer and Engineering (IJSCE), vol. 3, Issue 2.
- Shalal, A. H., and Rawaa, and Osama, 2013, *A Novel Method for Tuning PID Controller*, Diyala Journal of Engineering Science, vol. 6, No. 1.
- Venugopal, and Ajanta, and Priyanka, 2013, *Design of Tuning Methods of PID Controller using Fuzzy Logic*, International Journal of Emerging Trends in Engineering and Development, vol. 5, Issue 3.

### NOMENCLATURE

$B$  = viscous friction coefficient, mH.

$i_a$  = armature current, Ampere.

$J$  = moment of inertia, Kg.m<sup>2</sup>.

$K_0$  = constant gain.

$K_b$  = electromotive forces constant, V/rad/s.

$K_D$  = derivative gain.

$K_I$  = integral gain.

$K_P$  = proportional gain.

$K_t$  = torque constant, N.m/rad/s.

$L_a$  = armature inductance, mH.

$R_a$  = armature resistance, ohm.

$T_m$  = torque.

$V_a$  = input voltage.

$V_b$  = back voltage.

$\omega_m$  = motor angular velocity.

$\tau_I$  = time constant.

$\tau_2$  = time constant.

$\tau_D$  = derivative time constant.

$\tau_I$  = integral time constant.

**Table 1.** The parameters of DC servo motor, **Dipraj, and Pandey, 2012.**

Parameter	Value	Units
$L_a$	29.79	mH
$R_a$	1	$\Omega$
$J$	0.01	Kg.m <sup>2</sup>
$B$	0.004	N.m/rad/s
$K_t$	0.052	N.m/rad/s
$K_b$	0.1	V/rad/s



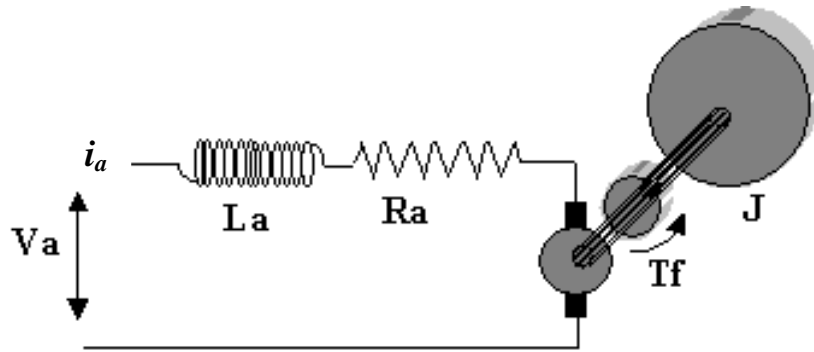

Figure 1. DC servo motor model.

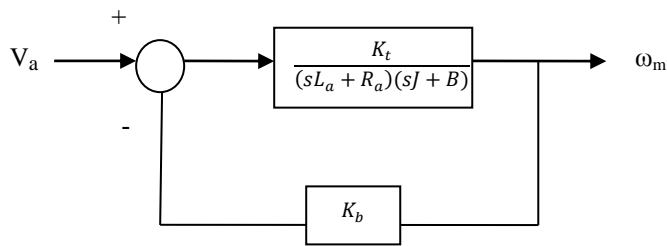

Figure 2. The block diagram of DC servo motor.

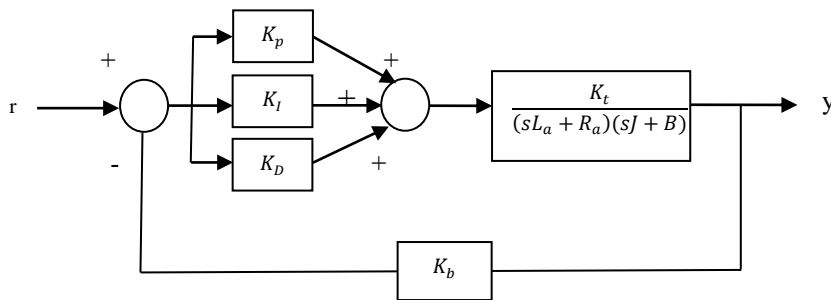

Figure 3. The block diagram of DC servo motor with PID controller.

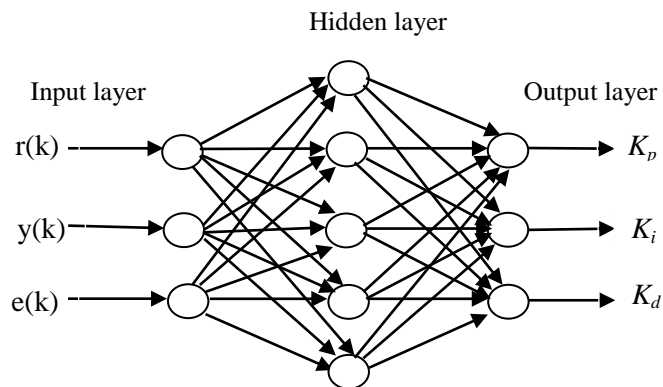

Figure 4. Structure of BP neural network

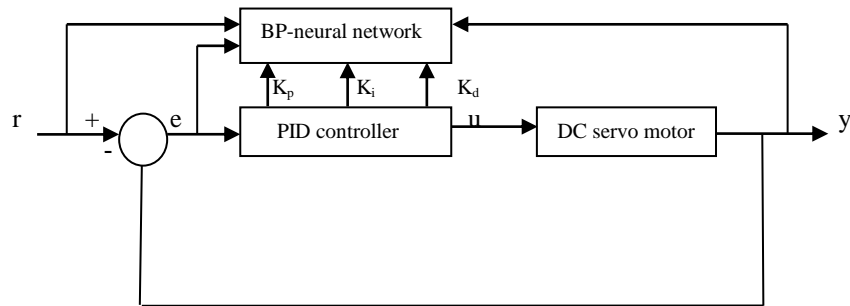

Figure 5. Block diagram of neural network-PID controller.

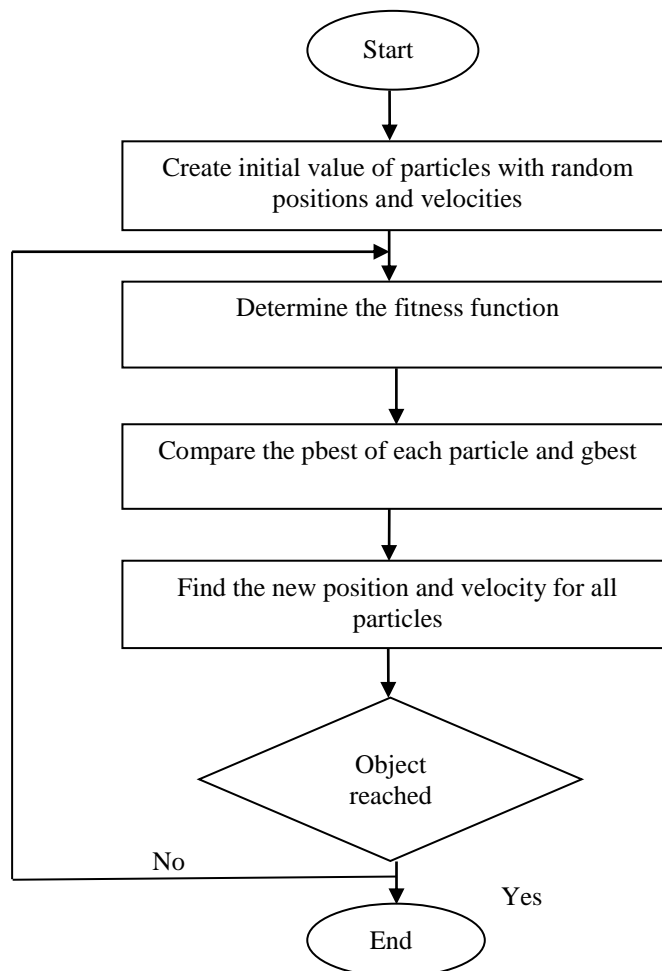
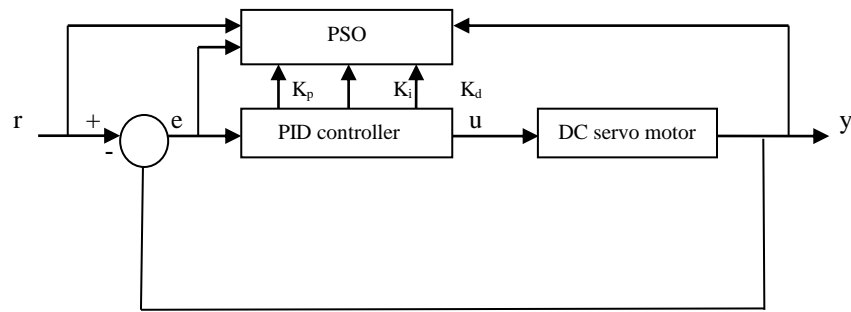
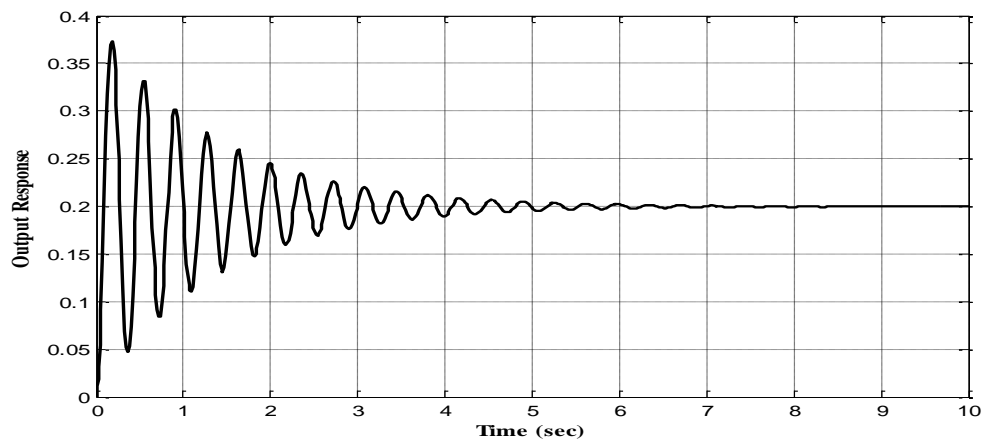

Figure 6. Flow chart of PSO algorithm tuning for DC servo motor.



**Figure 7.** Block diagram of PSO-PID controller



**Figure 8.** The closed loop transfer function for the DC servo motor without controller.

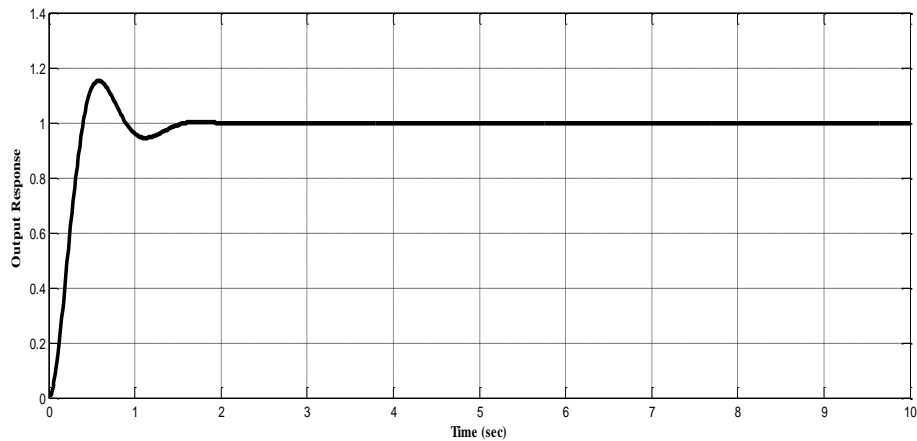

**Figure 9.** The DC servo motor transfer function with PID controller.

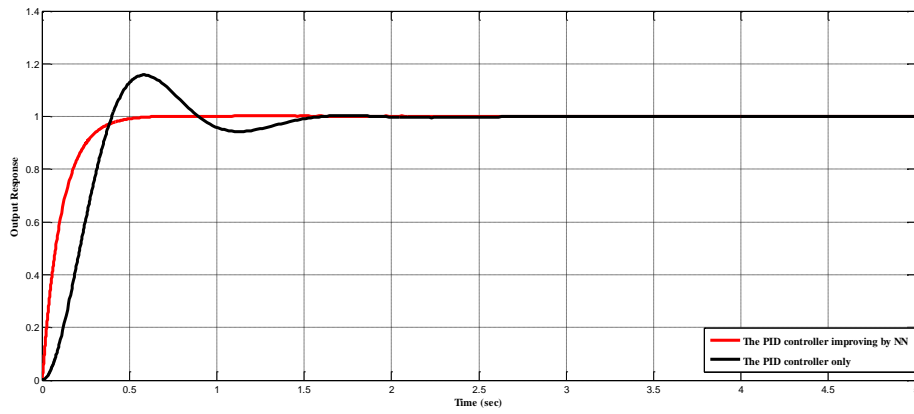

**Figure 10.** The comparison of PID controller with and without neural network method.

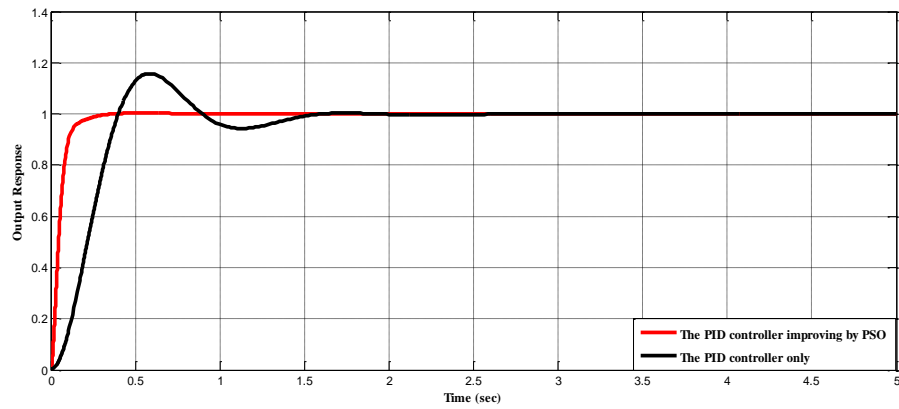

**Figure 11.** The comparison of PID controller with and without PSO Method.

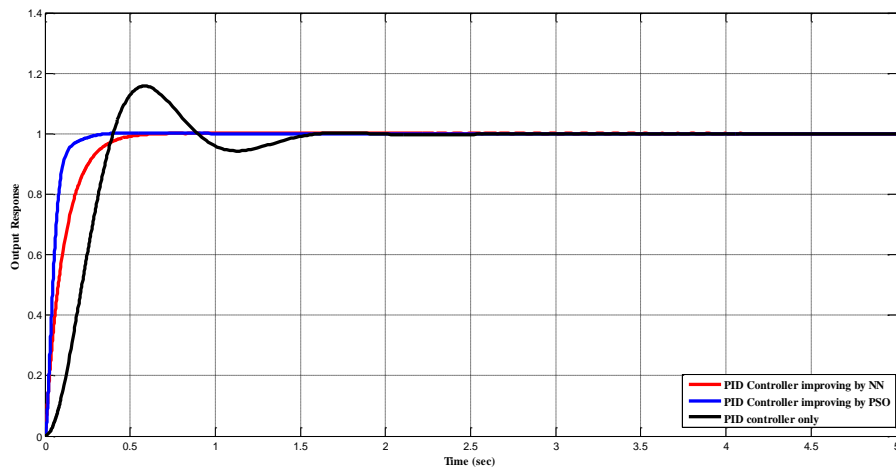

**Figure 12.** The comparison of controls with and without improving Methods.