

Compliance of Haditha Dam in Iraq to the International Standards for Surveillance and Monitoring

Alyaa Jumaah Hadi^{1,*}, Thamer Ahmed Mohammed²

Department of Water Resources Engineering, College of Engineering, University of Baghdad, Baghdad, Iraq
Alaia.Hadi2110m@coeng.uobaghdad.edu.iq, thamer.a.m@coeng.uobaghdad.edu.iq²

ABSTRACT

Dams are mega structures that retain huge volumes of water and their safety is important to national security, economy, and public interest. In this study, the types of regular measurements with their recorded value for Haditha Dam were checked for compliance with the standard international surveillance and monitoring procedures such as the procedures of the International Commission on Large Dams (ICOLD), the United States Bureau of Reclamation (USBR) and other to ensure safe dam operation and to avoid the scenario of the Derna Dam break, in Libya that occurred in September 2023. The result shows that the highest recorded settlement was found at station 41 on the left side of the dam body exceeding the design criteria (219 mm) by about 51 %, the frequency of measurement does not comply with the required international standards. There are 7 cells of pore pressure that exceeded the design criteria and the greatest percentage of exceedance was 21.57 % was found at pore pressure number 995. For piezometer reading, the percentage exceedance was 9.1% and it was found on the left side at piezometers number 58-8. The highest percentage of movement 62 % was found at join meter device number D18. The recorded seepage rate through the dam was found within the permitted limits. The visual inspection followed at Haditha Dam was not according to the standard required inspection.

Keywords: Embankment dam, Surveillance, Settlement, Piezometers, Seepage, Visual inspection.

*Corresponding author

Peer review under the responsibility of University of Baghdad.

<https://doi.org/10.31026/j.eng.2024.07.03>

This is an open access article under the CC BY 4 license (<http://creativecommons.org/licenses/by/4.0/>).

Article received: 22/11/2023

Article accepted: 29/05/2024

Article published: 01/07/2024



مدى إمتثال سد حديثة في العراق لمتطلبات المراقبة والاستطلاع القياسية العالمية

علياء جمعة هادي*، ثامر احمد محمد

قسم هندسة الموارد المائية، كلية الهندسة، جامعة بغداد، بغداد، العراق

الخلاصة

السدود هي هياكل ضخمة تحتفظ بكميات هائلة من المياه وسلامتها مهمة للأمن القومي والاقتصادي والمصلحة العامة.. في هذه الدراسة، تم فحص أنواع القياسات المنتظمة مع قيمتها المسجلة لسد حديثة للتأكد من امتثالها لإجراءات المراقبة والاستطلاع الدولية القياسية مثل إجراءات اللجنة الدولية للسدود الكبيرة (ICOLD)، ومكتب الولايات المتحدة للاستصلاح (USBR) وغيرها لضمان التشغيل الآمن للسد وتجنب سيناريو انهيار سد درنة في ليبيا الذي حدث في سبتمبر 2023. تشير النتائج الى أن أعلى نسبة للهطول سجلت في سد حديثة كانت في الجانب الايسر لجسم السد عند المحطة 41 والتي تجاوزت الحدود التصميمية بمقدار 51% وكانت المدة المطلوبة لتكرار قياس الهطول غير مطابقة للمعايير الدولية. هنالك 7 خلايا لقياس ضغط الماء في مسامات تربة السد حيث إن أعلى نسبة كانت قد سجلت في خلية قياس الضغط رقم 995 حيث تجاوزت الحدود التصميمية بنسبة 21.57%. بخصوص قياس مستوى المياه في البيزومتيرات في السد فان أعلى نسبة قد تجاوزت الحدود التصميمية بمقدار 9.1% عند الجانب الايسر في البيزوميتر رقم 58-8 بالنسبة لمراقبة البيانات الإنشائية الخاصة بمنشأ السد، تم ملاحظة أن أعلى نسبة لحركة المفاصل الإنشائية كانت 62% أكبر من الحدود التصميمية المسموح بها وقد سجلت في جهاز قياس الحركة رقم 18. كان معدل التسرب المسجل خلال جسم السد ضمن الحدود المسموح بها. إن الفحص البصري المتبع في سد حديثة لم يكن وفق معيار الفحص المطلوب.

الكلمات المفتاحية: سد ترابي، مراقبة، الهطول، بيزومتيرات، رشح، الفحص البصري.

1. INTRODUCTION

Dam safety results from a coordinated plan that includes responsible ownership, conscientious use of the best engineering design and maintenance methods, suitable governance, licensing and regulatory arrangements, robust management and operational procedures, and river basin-specific operational procedures (**ICOLD Bulletin, 2020**). The definition of surveillance is the observation of the dam and any related structures. To keep the dam in good condition for safety and the ability to carry out its functions (**Auckland Regional Council, 2012**). Every dam monitoring report includes information on all factors impacting the dam's safety during the time since the last Surveillance Report in a single document (**Dams Safety Committee, 2010**). The main focus of the efforts will be finding any modifications. Although trends are often relatively modest, earth-fill dams, in particular, are at risk of rapid deterioration (**Vincent et al., 2020**). **Fig. 1** highlights the scope of the definition of the term "dam surveillance" (**ICOLD, 2018**). There is much research related to the dam and dam safety that was conducted by local and international researchers. (**Johansson, 1997**) conducted research on monitoring of seepage in embankment dams in Sweden by using resistivity data. The first approach examines the lag in resistivity between the reservoir's and the dam's interior. The lag time and the seepage path's length are the direct sources of the velocity. The second approach assumes that seepage is localized in a



zone where it is significantly higher than in the surrounding areas. The method shows promise for quantitative assessment.

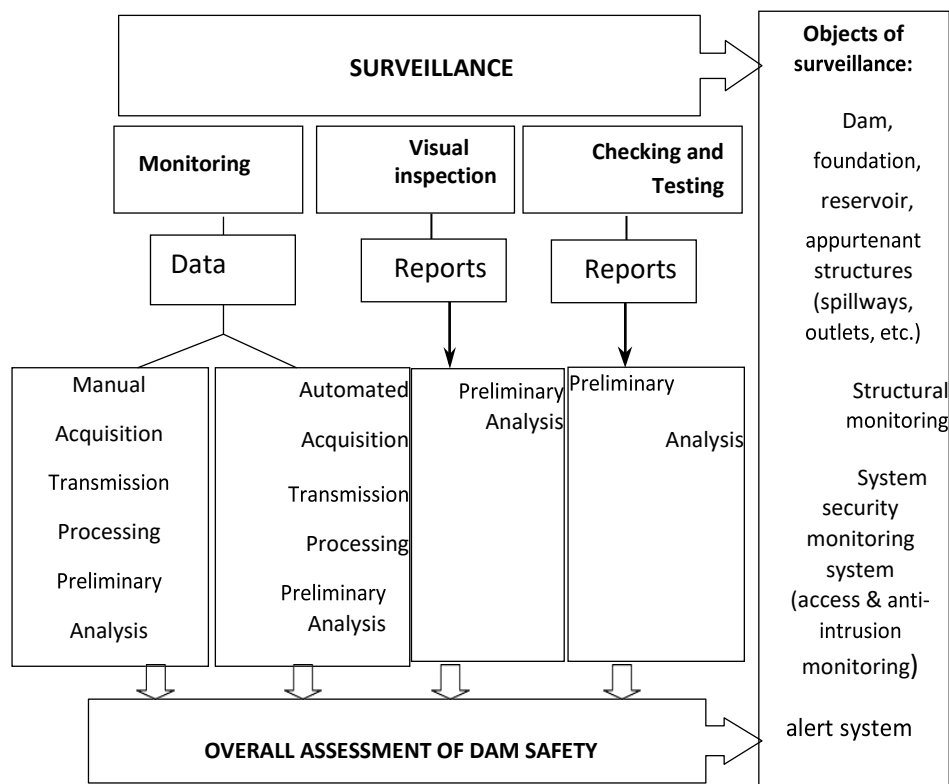

Figure 1. Definition of the Concept of Dam Surveillance (ICOLD, 2018)

(Mainali et al., 2015) used self-potential (SP) and electrical resistivity methods to study seepage in tailings dam in Swedish. The resistivity method involves the measurement of the apparent resistivity of soil and rocks as a function of depth or position. The resistivity of the ground is measured by injecting current with two electrodes for measuring the resulting potential difference with two other electrodes. The readings are usually converted into an apparent resistivity of the sub-surface. From these measurements, the true resistivity of the subsurface can be estimated.

(Glisic et al., 1999) monitored dam safety by using sensors from optical fiber structures of two monomode types in France. The measuring fiber tracks the deformation of the host structure by being in mechanical touch with it. Also, (Fabritius et al., 2017) used fiber optic sensors for dam monitoring in South Africa. (Alba et al., 2006) investigated laser scanners for the structural monitoring of Cancano Lake (Valtellina, Italy). The concrete dam structural monitoring methodology is divided into two parts. The first one was fieldwork. At that stage, the information was obtained using a Terrestrial Laser Scanner (TLS) following basic principles and processes. The laboratory work represented the second stage. At that point, the data is processed to provide results and evaluate the data. (Aufleger et al., 2007) worked in an innovation dam and (González-Aguilera et al., 2008) worked at Las Cogotas dam in Spain. (Luzi et al., 2010) used advanced techniques such as Real Aperture Radar (RAR) and Synthetic Aperture Radar (SAR) sensors for dam monitoring. The research offers two new radar-based remote sensing methods that could be useful for monitoring dams. The first method creates 2D imagery by using data that is obtained from a (SAR) sensor. Using



interferometric techniques, displacement estimates with sub-millimeter precision can be obtained from this image system. The second method measures and tracks the vibrations of infrastructure and man-made objects as a 1D profile by using (RAR) data obtained by a similar device but with a different configuration. Both methods proved to be effective and potent instruments. Ground Penetrating Radar (GPR) for dam monitoring Acerenza dam in Southern Italy was applied by **(Loperte et al., 2011)** to assess the dam site and they discovered that all sandstone layers below the embankment dam were probably fractured, and this could lead to dam failure. The GPR is a surface-geophysical technique that depends on transmitting electromagnetic pulse, reflecting, and creating continuous high-resolution files. **(Sunantyo et al., 2012)** investigate several sensors that were permanently installed in a Sermo Dam, Indonesia as a case study such as 3D Robotic Total Station (RTS) sensor, various permanently fixed prisms, two GNSS CORS units, an Automatic Water Level Recording (AWLR) sensor, and a zoom digital IP camera. **(Millo et al., 2016)** monitored the dam's structural health from space using Interferometric Synthetic Aperture Radar (InSAR) approaches and multi-parametric modeling. To guarantee efficient dam monitoring, **(Borghero, 2017)** reviewed the (InSAR)-based feasibility study of dam deformation monitoring of the Ajaure dam, Sweden. SAR is an imaging system that uses microwave pulses to provide electrical and geometrical features of surfaces. The antenna sends pulses to the ground and analyzes the echo that returns in the antenna look direction producing photographs of the Earth's surface data for assessing ground deformation and images can be collected at any time of day or night. The management system for dam safety assessment in Iraq was conducted by **(Mahdi and Rezouki, 2017)**. Based on instrumentation data, **(Hossein et al., 2017)** investigated the monitoring of the Masjed Soleyman rock-fill dam in Iran, which was carried out during the structure's building and operation period, using data from sensors set on the dam's body. The dam's barometer is arranged in three clusters. These barometer cells are installed (upstream, center, and downstream of the core, upstream and downstream filter, upstream and downstream shell). **(Pipitone et al., 2018)** conducted a study on monitoring a reservoir water surface and level using various remote sensing techniques. The results were compared with dam displacements measured using the Global Navigation Satellite System (GNSS). Earth and rock-filled dam monitoring by high-resolution X-band interferometry was applied by **(Li et al., 2019)** where Gongming dam was taken as a case study. For 14 large dams in Thailand, Automated Dam Safety Evaluation was studied by **(Supakchukul et al., 2019)**, the research focuses on the dam safety remote monitoring system (DS-RMS), which is used by Thailand's Electricity Generating Authority (EGAT) right now. The evaluation procedure begins with sending movement information to a server and adjusting to engineering data. The system will make noise if data is out of range. In addition, **(Qiu et al., 2020)** studied (InSAR) in the Geheyuan Dam, China. The development of the Dam Safety Remote Monitoring and Evaluation System in Thailand was investigated by **(Suwatthikul et al., 2021)**. **(Reguzzoni et al., 2022)** conducted research on the use of (GNSS) for dam monitoring in an Italian embankment dam. **(Jänichen et al., 2022)** investigated Monitoring of Radial Deformations of a Gravity Dam in Germany Using Sentinel-1 Persistent Scatterer Interferometry.

(Bonelli and Royet, 2001) studied the analysis of dam monitoring data using delayed response and their technique was based on Darcy's law and Richard's equation of seepage, for linear dynamic systems by considering non-aging elements such as reservoir level and rainfall events in determining pore-pressure variability. **(Darbre and Proulx, 2002)** monitored the Mauvoisin arch dam ambient vibration from the surrounding environment continuously twice a day for six months by using an automated system installed on the dam.



Throughout the testing period, frequency shifts were monitored, and the impacts of the fluctuating water level were determined. In Basrah, Iraq, **(Al-Farouk et al., 2003)** studied soils' behavior during consolidation, which is numerically solved and described using the finite elements approach. Furthermore, the degree of saturation has an impact on the consolidation process. Given that the routes in the soil that pore-water and/or pore-air use can change from one state to another. Also, both isothermal and non-isothermal instances were studied in the research. **(Marini et al., 2004)** conducted monitoring and safety evaluation for Ridracoli dam in Italy using the expertise obtained from automatic monitoring and a knowledge-based support system. This helps identify surveillance operations to control unusual tendencies or reduce dangerous circumstances brought on by flooding. **(Pytharouli and Stiros, 2005)** determined if any variations in reservoir level could cause dam deformation. They investigated geodetic monitoring to record the horizontal and vertical displacements of six control stations installed on the crest of the Ladon concrete dam. The dam's displacements were maximal in the middle of the dam, relatively modest (up to 7 mm), and statistically significant against random errors. The efficacy of statistical models for dam monitoring data was examined by **(Chouinard et al., 2006)**. Using a simulation model, they developed guidelines about the model's applicability to various dam types. These guidelines considered the duration of measurement records, the frequency of readings, the uncertainty surrounding various measure types, and dam pathologies. **(Gikas and Sakellariou, 2008)** conducted settlement analysis of the Mornos earth dam using numerical modeling and geodetic monitoring. **(Al-Sadik and Al-Kanani, 2009)** conducted the displacement computation of the Mosul dam, Iraq using free geodetic network adjustment. **(Al-Shlash et al., 2010)** studied the effect of pore water pressure parameters on the stability of the AL-Ad'daim earth dam. **(Kibler et al., 2011)** conducted, experimental design, and established significance analysis methods for dam removal. Geotechnical instrumentation, monitoring, and surveillance in earth dam safety programs were studied by **(Srivastava, 2011)** where he examined several monitoring instrumentations for surveillance of earth dam safety. Various types of measuring, such as alignment and tilt, the stresses and strains in the soil and rocks, the pore pressure, the uplift pressure, the quantity of seepage, and the horizontal and vertical movement, were tested. **(Bashar et al., 2015)** calibrated and verified the hydraulic model for the Blue Nile River from Roseires Dam to Khartoum city. The verification requirements were met by applying the observed data for a future period and comparing it with the verification results. The calibration procedures were carried out utilizing the observed data from a prior period and comparing them with the calibration results. The Matlab software based on the least squares method and ellipse of errors was used for the Mosul dam by **(Khalaf et al., 2018)** to investigate the deformation in geodetic networks. The statistical model optimized random forest regression model for concrete dam deformation monitoring was researched by **(Dai et al., 2018)**. The derivation of the operation rule for Ilisu Dam, Turkey was investigated by **(Ali and Abed, 2018)**. **(Rahmati et al., 2019)** investigated based on site selection for Check Dams in Watersheds using Geographic Information Systems (GIS) and taking geomorphometric and topohydrological factors into account. **(Sadiq and Albusoda, 2020)** researched experimental and theoretical determination of settlement of shallow footing on Liquefiable soil. **(Alzamily and Abed, 2022)** investigated seepage reduction by zoned earth dam material with a unique core through experimental and theoretical investigations. They examined soils with varied additive percentages and assessed the soil innovation model by contrasting experimental and numerical outcomes. When 10% cement kiln dust (CKD) and 5% cement were added, the permeability of the sandy type (C) soil model was found to be quite similar to that of clay



soil. **(Ghali and Azzubaidi, 2021)** researched Hemrin Dam Flood Wave Management employing the HECRAS program. **(Gaagai et al., 2022)** examined dam-break flooding modeling and risk analysis. The purpose of the study was to model a break of embankment dam in northeast Algeria and investigate the propagation of flood waves resulting from the dam failure using HEC-RAS. The study performed the analysis of the three factors (slope, width, and time) at different locations downstream of the dam. The study of Digital Image Correlation (DIC) as a tool for testing concrete buttress dam failure models and their monitoring was investigated by **(Jensen and Leijström, 2022)**. They worked on determining whether (DIC), a photogrammetric application, can be used to monitor a dam model's displacement in a lab setting and to evaluate the method's applicability for large-scale dams. A 1:15 scale model of a dam was used for the experiment, and it was exposed to rising reservoir pressure until the dam broke.

(De Munain et al., 2012) worked on dam safety monitoring to assess the Val dam behavior, in Spain. They used safety-relevant equipment deformation measurements at the foundation, crest, joint, cracks; changes in the foundation (uplift, seepage, and erosion), and aging areas of the dam body and its foundation materials. **(Cheng and Zheng, 2013)** applied two online dam safety monitoring models based on the extraction of environmental influence. The analysis of a real-time monitoring system for workers' behavior at a large-dam construction site was investigated by **(Lin et al., 2013)**. **(Wang et al., 2014)** monitored the decadal lake dynamics across the Yangtze Basin downstream of Gorges Dam, China. The eastern Nile sub-basin situational assessment for dam safety management was prepared by **(Charlwood et al., 2014)**. **(Buchanya et al., 2014)** conducted a study on static and dynamic testing to evaluate the health of concrete dams. They assessed concrete dam health case studies by considering many approaches that have been based on analyzing data on this area. A taxonomy of tasks in dam cracks surveillance for augmented reality applications was the main emphasis of **(Peres et al., 2018)**. Dynamic monitoring of a concrete arch dam during the reservoir's first filling was investigated by **(Pereira et al., 2018)**. The study by **(De Membrillera et al., 2019)** Some ideas and suggestions on performance problems and flaws in dam monitoring. The case study was on the Ebro Dam in Spain. In their paper, they discuss the greatest flaws encountered in pendulums, especially inverted ones. The most common reasons for flaws include verticality problems with boreholes, and coatings that erode and deposit in metal pipes (PVC or concrete are generally preferred). The research of a framework for deterministic Monte Carlo simulation that assesses dam safety flow control was done by **(King and Simonovic, 2020)**. **(Seyed-Kolbadi et al., 2020)** studied instrumentation for health monitoring of the Boostan earth dam. The investigation performance and analysis of the measured data serve to assess its stability. Several sensitive areas are instrumented to measure the dam response. They use inspection tools like regular and casagrande piezometers, as well as total pressure cells, to determine various parameters like pore pressure, and elevation of water. **(Adamo et al., 2021)** studied dam safety focused on the standard instrumentation and monitoring used to determine the underlying causes of common problems, such as water level detection piezometers observation wells, and calibrated containers. **(Chen et al., 2020)** investigated the use of an adaptive kernel extreme learning machine for the prediction, monitoring, and interpretation of dam leakage flow. According to **(Clarkson et al., 2021)**, Real-time tailings dam monitoring reduces the amount of time spent collecting data and accelerating the analytical process. One such suggestion is the ability to process and acquire real-time data from multiple instruments to generate alarms and notifications. Anytime, anywhere, authorized users can access centrally stored monitoring data. **(DOUGLAS, 2021)** studied the types of instruments that are needed

during the construction and operation of an existing dam in Athens, Greece. Also, (Kale et al., 2022) studied the evaluation of occupational safety in dam operation and maintenance activities in Izmir, Turkey. (Monteiro-Alves et al., 2022) examined Failure of the downstream shoulder of rock-fill dams owing to overtopping or through flow. the configuration of the dam, which included the downstream gradient (1 to 3.5 H: V), the dam's height (0.2 to 1 m), the length of the valley (0.4 to 2.5 m), the medium size of uniform gravel (7 to 45 mm), and the type of impermeable element (i.e., central core, upstream surface, and no impermeable element) were tested for 114 physical models (PMs) in the experimental investigation.

The specific objective is to evaluate the surveillance and monitoring procedures currently followed in operating Haditha Dam against international standards such as ICOLD and other standards based on geotechnical, structural, hydrological, and environmental parameters, in addition to visual inspection.

2. METHODOLOGY

2.1 The Case Study

Located on the Euphrates River, north of Haditha City in the Al Anbar Governorate of Iraq, is the zoned earth-fill Haditha dam. The dam's construction was finished in 1987, having started in 1977. The Power House is situated 3,310 meters away from the southern border of the 9064-meter-long and 57-meter-high Haditha Dam. The crest of the dam measures 20 meters in width and 154 meters above sea level (m.a.s.l.). The core of the dam is composed of an asphaltic concrete cutoff, mealy detrital dolomites, and a mixture of sand and gravel, as shown in Fig. 2 (Adamo et al., 2018).

2.2 The Proposed Approach to Study

As mentioned, the studied dam was compared with the following standard approaches to assess compliance with international surveillance requirements. The State Commission for Dams and Reservoirs should collect a large amount of data from various equipment. The proposed approach is summarized in Fig. 3.

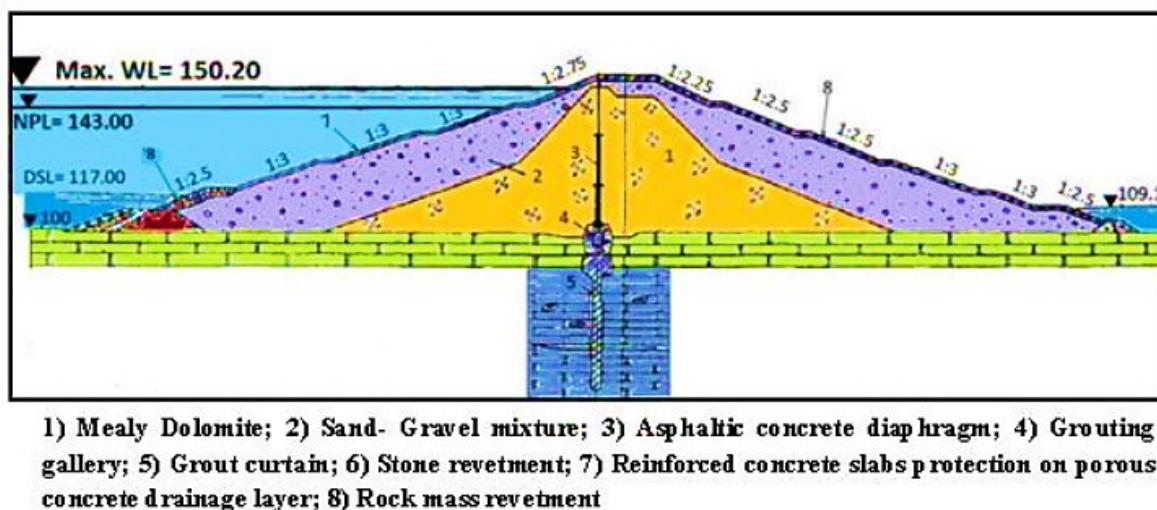

Figure 2. Typical cross-section of Haditha dam (All levels are in m.a.s.l)
(Adamo et al., 2018)

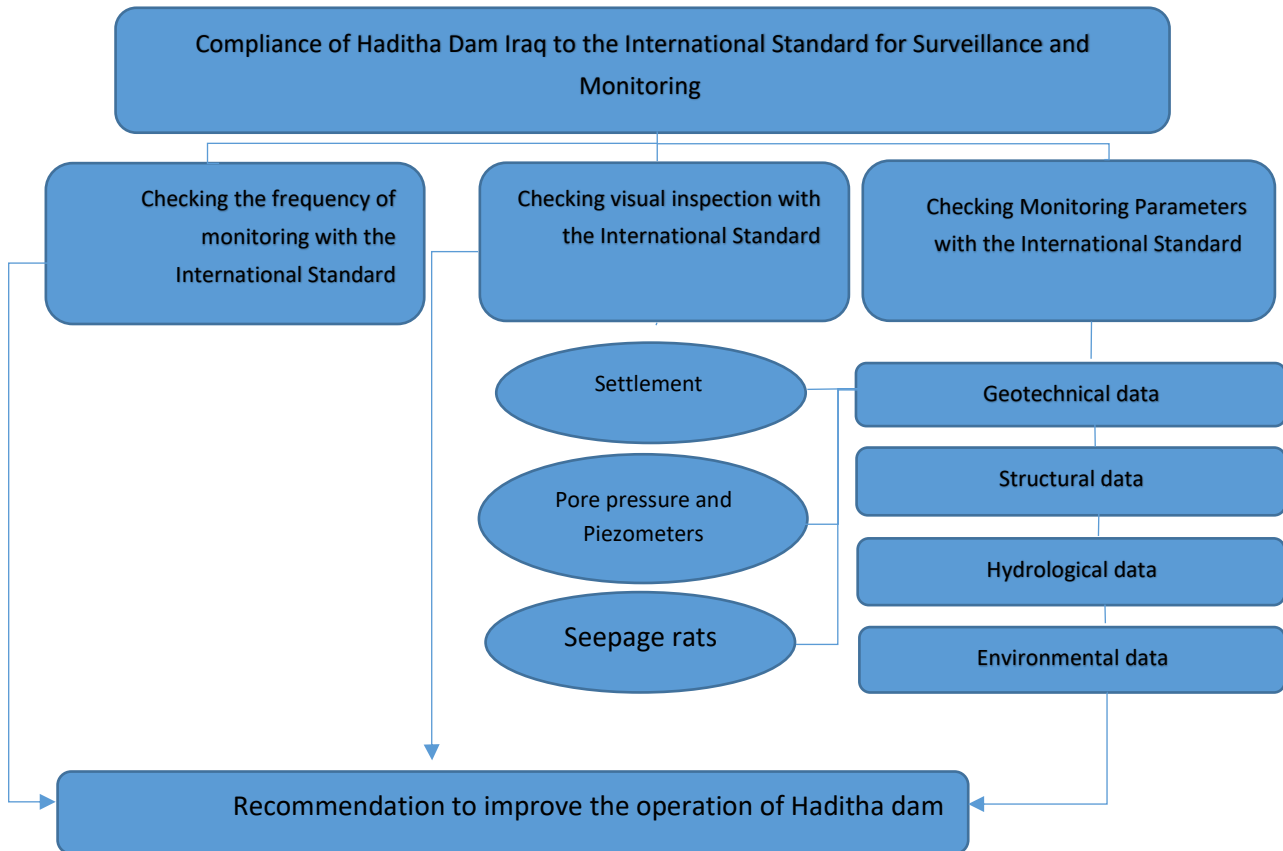

Figure 3. Flow chart of the proposed approach for the study.

2.3 Monitoring Parameters

Parameters that affect the stability of a dam can be categorized as geotechnical, structural, hydrological, and environmental

2.3.1 Monitoring of Geotechnical Parameters

The monitored geotechnical parameters included settlement, pore water pressure, piezometers, and seepage. The foundation is the most important component of a dam, and it may be at risk due to settlement, which is often caused by a faulty foundation.

2.3.2 Monitoring of Structural Parameters

This parameter includes measuring joint meters and a Pendulum device to monitor the movement of the hydroelectric station.

2.3.3 Monitoring Hydrological Parameters

The issue of the variation of water volumes behind and after the dams is important for operational and control purposes. The intensity of precipitation and potential evaporation can also influence the amount of storage. The water balance equation is mostly a reliant tool used for the estimation of inflow into the dam reservoir.

2.3.4 Monitoring Ecological and Environmental Data

To determine the quality of the water and in the event of any defect in the rock formations that make up the dam's body.

3. RESULTS AND DISCUSSION

3.1 Monitoring Geotechnical Parameters (Settlements)

Surface marks that had been disturbed at various stations on the dam body, crest, hydropower station, and retaining walls were used to measure it. Using surveying equipment, the distance between them is 100 mm to 200 m. Surface markers were positioned in the dam's berm at elevations (EL.) of 115.125, 135, and 145 meters above sea level (m.a.s.l) on the left and right sides of the dam body. **Fig. 4** displays the locations of the surface marks. Surface markers from stations 22 to 37 are located on the right side, ranging from 4 to 15. Except for one measurement made at station 29 (El. 125 m.a.s.l.) on 1/1/ 1988, which was determined to be 28 mm, most of the measured settlement values at the stations did not exceed the design parameters. Between January 1, 1988, and November 19, 2020, the total settlement was 210 mm, exceeding the design criteria of 110 mm by approximately 9.10%. Surface markers (4 to 26) are arranged between stations 41 to 67 on the left side. The recorded total settlement value ranges from 14 to 98 mm, while the design criteria value ranges from 100 to 360 mm.

Fig. 5a shows the value of the recorded settlement on 1/1/1988 at the stations that exceeded the design criteria where the highest recorded settlement was found at station 41 at (EL. 125 m.a.s.l). **Fig. 5b** shows the total recorded settlement from 1/1/1988 to 19/11/2020 for the same stations the highest recorded settlement(331mm) was found at station 41 on the left side of the dam body exceeding the design criteria (219 mm) by about 51 %.

At station 44 (EL.115 m.a.s.l.), the lowest exceeded percentage was discovered to be 35%. All things considered, the data indicates that the dam's first year of filling saw the highest level of settlement. Subsequently, the documented settlement values decreased, indicating a tendency for the dam to stabilize. A study conducted by the United States Bureau of Reclamation (USBR) found that almost two-thirds of all dam failures were caused by internal erosion and that about half of all dam failures happened during the first filling or in the first five years following the start of the dam's operation.

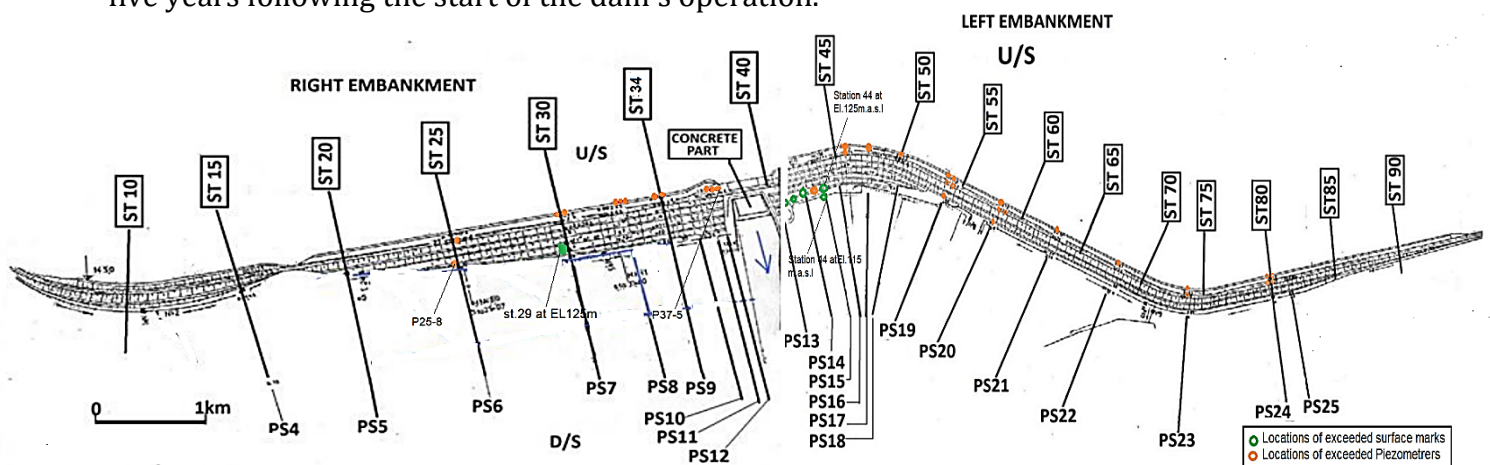

Figure 4. Locations of exceeded surface marks and piezometer level. (The State Commission of Dam and Reservoir, 2020)

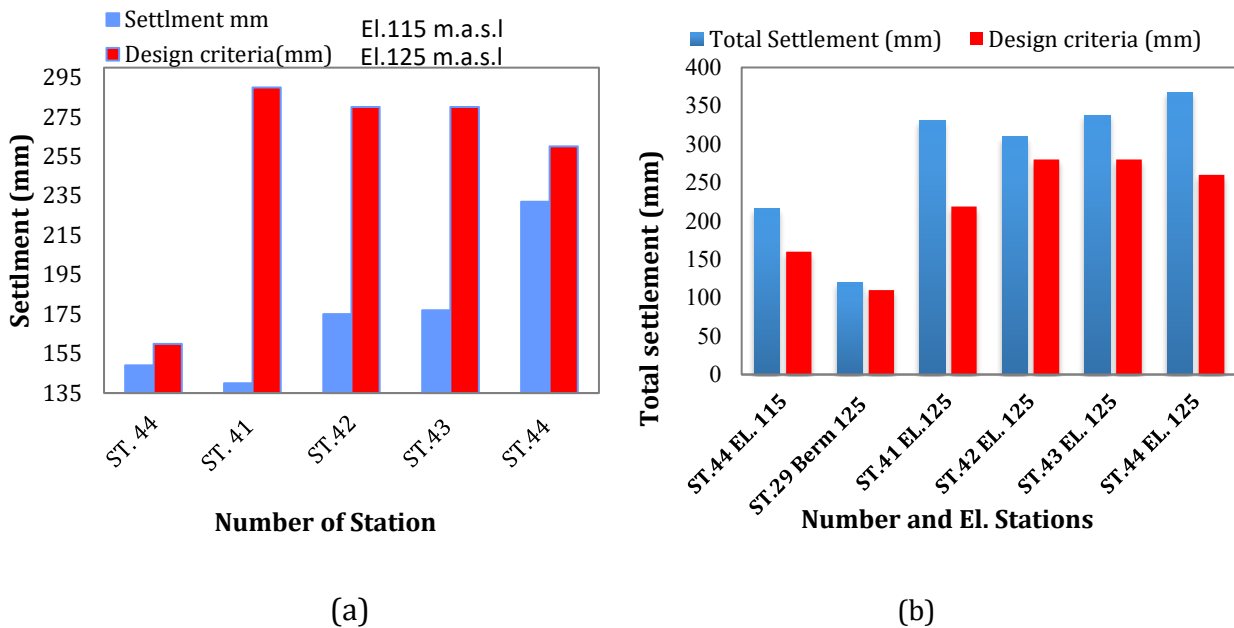

Figure 5. Recorded settlement on the left side of the dam body from 1/1/1988 to 19/11/2020. (a) Recorded Settlement on 1/1/1988. (b) Total settlement from 1/1/1988 to 19/11/2020.

The surface marks on the dam's crest were disrupted between stations 8 and 37 on the right side and between stations 41 and 90 on the left. All of the recorded values fell between 100 and 360 mm, which was the range of the design criteria. The six plates at El 145 m.a.s.l. and the nine-rod markings at El 154 m.a.s.l., which are dispersed across the stations from 30+05m to 43+97m upstream and downstream of the dams, are the divisions of the deep observation markers. The recorded total settlement value did not surpass the design parameters, which varied between 130 and 270 mm. The surface marks of the hydroelectric station are located at elevations of (110,141 and 154 m.a.s.l). At an elevation of (110 m.a.s.l.) there are 12 surface marks 4 on each side (left, central, and right). The highest value of the total settlement at the left surface mark number (LP 110 - 4) was found to be 16.12 mm, which exceeded the design criteria by approximately 74.6%. The recorded total settlement values from August 2002 to November 2020 ranged from 10.55 to 16.12 mm, while the design criteria are given as 15 mm.

As seen in **Fig. 6**, the lowest recorded total settlement values at the left surface mark number (LP 110 - 1) were determined to be 16.2 mm, exceeding the design criteria by around 8%. At EL (141 m.a.s.l.), there are twelve surface marks. Four of them are situated on the left, center, and right. The recorded total settlement values between August 2002 and November 2020 were found to vary between 0.9 and 8 mm, although the design criteria value was 15 mm. Nothing exceeds the design parameters. Nonetheless, eight surface markings at EL.of (154 m.a.s.l.) were discovered to have total settlement values ranging from 0.7 mm to 5.7 mm between August 2002 and November 2020, despite the design parameters stating 15 mm. Also, no settlement values exceeded the design criteria.

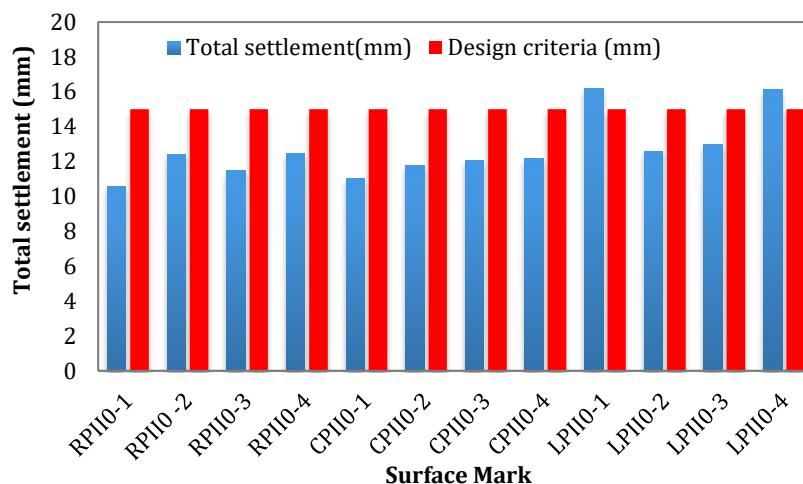

Figure 6. Recorded total settlement for the surface mark at the Hydroelectric station at elevation 110 m.a.s.l.

The dam includes two retaining walls, each wall consists of three separate parts connected by a key and constructed at El. (129,135 and 142) m.a.s.l. There are 14 surface marks on the right side, the recorded total settlement was (36 to 232) mm from 5/4/1990 to 19/11/2020 and zero reading was between (153.97 to 154.08) m.a.s.l. There are 14 surface marks on the left side, the recorded total settlement was (4 to 28) mm from 5/4/1990 to 19/11/2020 and the zero reading was between 153.928-154.01) m.a.s.l.

3.2 Monitoring Geotechnical Parameters (Pore Pressure Cells and Piezometers Level)

There are 29 pore water pressure cells (7 of them out of work) located in the area that separates the shoulder from the dam body and the origin of the hydroelectric station. From 14/1/2020 to 7/12/2020 the pore pressure in 8 pore cells and the number of these cells are (191, 207, 990, 993, 995, 1077, 1245, 1263) were found to be ranged from (129.8 to 148.4) m.a.s.l which exceeded the value of the design criteria (113.1 to 144.74) m.a.s.l as shown in **Fig. 7** based on data recorded up to 7/12/2020. The greatest percentage exceedance was 21.57 % and it occurred in cell number 995 while the lowest percentage of exceedance was 2.7 % and it occurred in cell number 1245 until 7/12/2020. The pressure cells are used to monitor the pore water pressure between the area that separates the shoulder of the dam body and the origin of the hydroelectric station.

There are 86 piezometers on the right side of the dam body distributed along many stations (15,20,25,29,30, 31,32, 34, 36,37), the data collected from 5/1/2020 to 22/12/2020 was used in the assessment. Only readings from 12 piezometers were found to range from (122.54 to 147.32) m.a.s.l. which exceeded the design criteria (122 to 140.74) m.a.s.l. The highest exceedance percentage of 6.6% occurred at piezometers number 37-5 which are located close to the powerhouse while the lowest exceedance percentage of 0.44% occurred at piezometers number 25-8 as shown in **Fig. 8 a**. There are 104 piezometers on the left side of the dam body, 10 piezometers are dry or under maintenance, and in 22 piezometers the readings were found to range between (103.7 and 134.5) m.a.s.l which exceeded the design criteria (104.21 -146.59) m.a.s.l. A higher percentage of 9.1% was found at piezometers 58 - 8 which is located far from the powerhouse. The lowest percentage of exceedance was 0.49% and it occurred at piezometers number 43-8 as shown in **Fig. 8 b**.

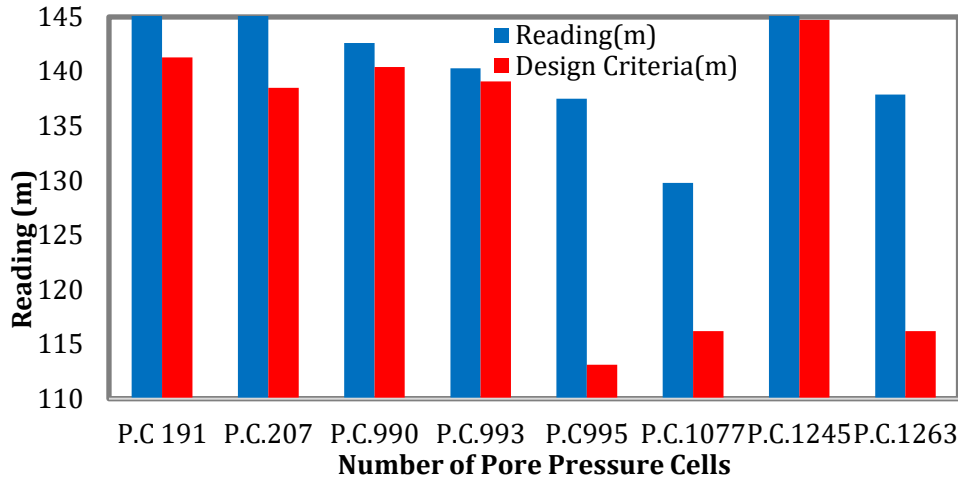
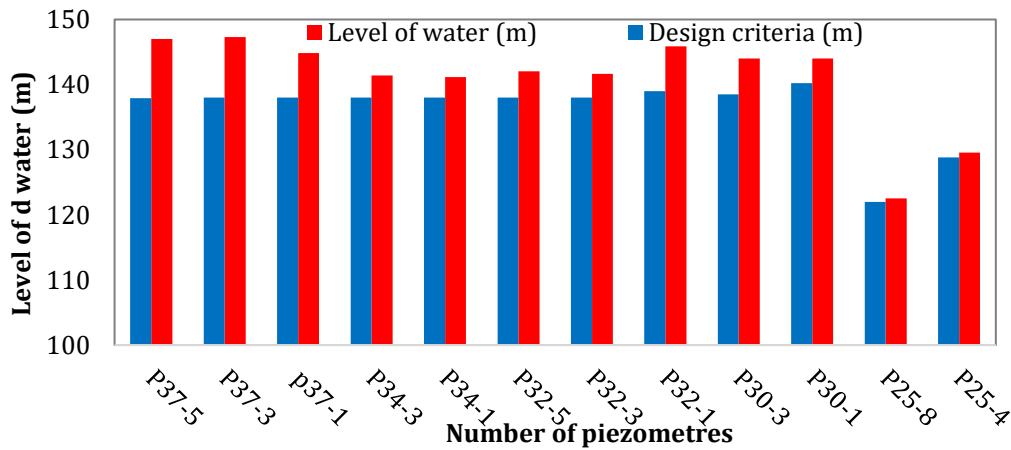
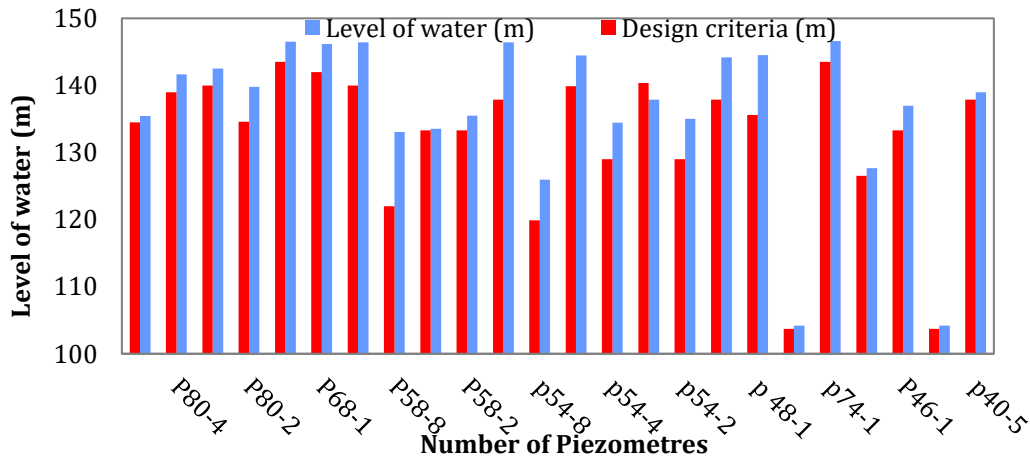

Figure 7. Exceeded pore pressure cells from 14/1/2020 to 7/12/2020.

The pressure cells were used for the first three years after filling the reservoir to monitor the pore water pressure while the piezometers were used to monitor the phreatic surface seepage during dam operation. The piezometers are not functioning due it was logged.



a. Piezometers of the dam body that exceeded design criteria on the right side



b. Piezometers of the dam body that exceeded design criteria on the left side.

Figure 8. Piezometers of the dam body that exceeded design criteria.



The piezometers on the hydroelectric and secondary stations. There are two types of piezometers (PU) to monitor uplift pressure under the foundations of the structure and their number was 91 piezometers. The other type is (PF) and their number was 32 to monitor the seepage paths under the rock layers below the structure. No readings exceeded the design criteria which ranged from (81.82 to 119) m.a.s.l.

3.3 Monitoring Geotechnical Parameters (Seepage Rate)

Drainage systems in the dam body consist of relief boreholes, drains, and weirs installed in the drain outlet. There are 64 relief boreholes on the right side from which 37 relief boreholes are working and the higher recorded rate of seepage water was 2.05 l/s. The other 27 boreholes were either dry or broken. But on the left side, there are 96 relief boreholes of which side 23 relief boreholes are working, and the others 73 are not working higher seepage rate was 0.54 l/s. Values of the measured seepage rate taken from 3 weirs in a station 26+86m, 32+41m, and 47+ 00m were found to be (1.84, 68.63, and 11.4) l/s respectively while the recommended design criteria for the above station was given as (13,165 and 135) l/s respectively. In the Hydroelectric station, there are 3 weirs the seepage rate from 2 weirs was found to vary from (13.8 to 14.6) l/s while the design criteria of seepage rate for 3 weirs was recommended 660 l/s and in the Secondary Station, the seepage rate for 2 weirs was (76.63 to 129.86) l/s while the design criteria recommended for 2 weirs was 200 l/s and no measuring value exceeding design criteria.

3.4 Monitoring Structural Parameters

There are 18 devices to measure joint meters between the main blocks of the dam structure. The locations of the device are shown in **Fig. 9 a**. The measurements are carried out in three directions (A, B, C). The recorded measurement was from 1/6/2016 to 8/12/2020. The readings of movement of joint meters device number 10 (D10) ranged between 2.5 mm to 15.3 mm exceeding the design criteria (given as 12 mm in direction A). The readings of movement of (D15) ranged from 5.2 mm to 7mm which exceeded the design criteria (given as 5 mm in direction B). However, the reading of the movement of D18 ranged from 5.2 mm to 8.1 mm exceeding the design criteria (5mm). The highest percentage of movement at D18 is 62% and it occurred in the last pieces of concrete that separated the bottom outlets from the natural land while the lowest percentage of movement was occurred at D10 and found to be 6.6% (**Fig. 9 b and c**). No leakage was observed in these joints as there is no sign of a defect found in them, and the main reason may relate to the effect of temperature.

Two pendulum devices are used to measure the horizontal movement in the Hydroelectrical station. The right Pendulum is not working means that there is no data on horizontal movement for the right part the displacement obtained from the left pendulum was taken from April 2008 to December 2020 and ranged from was (0.2 – 1.5) mm which found less than the given and the design criteria (3 mm). There are 26 devices to measure the movement of the rock layer but all of them have not working since 2006 because they were damaged by the presence of H₂S gas.

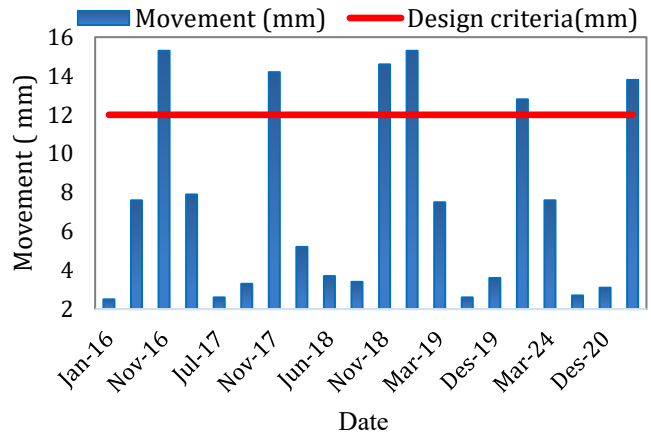
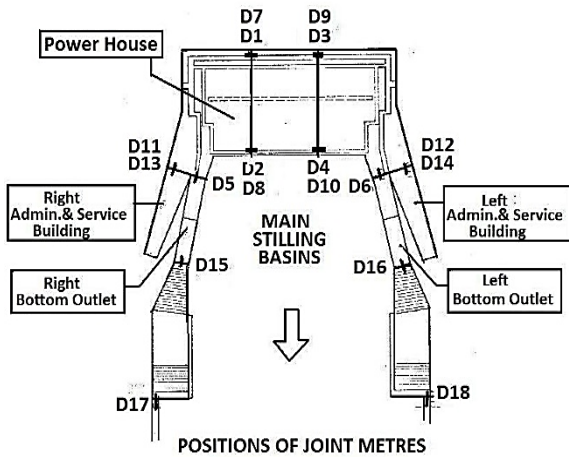

a. Locations of Joint meters

b. Measurement of exceeded device (D10).

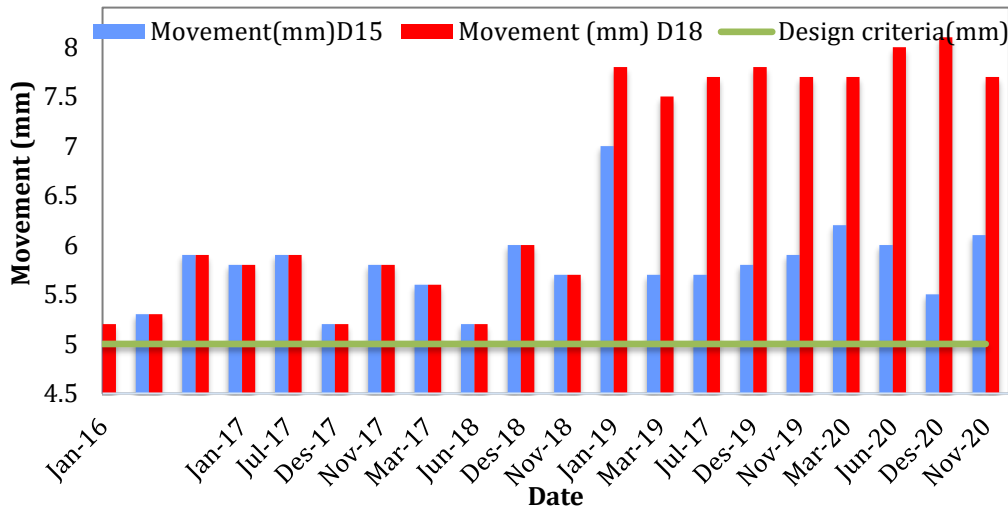

c. Measurement of exceeded device (D15, D18).

Figure 9. Measurement movement of exceeded joint meters device.

3.5 Monitoring Hydrological Parameters

The issue of the variation of water volumes behind and after the dams is important for operational and control purposes. The runoff rates from the catchment toward the dam cause significant buildup in the water storage. The water balance equation is mostly a reliable tool used for the estimation of inflow into the dam reservoir. The intensity of precipitation and potential evaporation can also influence the amount of storage. **Fig. 10** shows that the maximum storage for Haditha Dam from 1985 to 2019 does not reach the maximum storage at elevation 150 m.a.s.l was $9.7 \text{ m}^3 \times 10^9$ and it was $8.73 \text{ m}^3 \times 10^9$ in 2004.

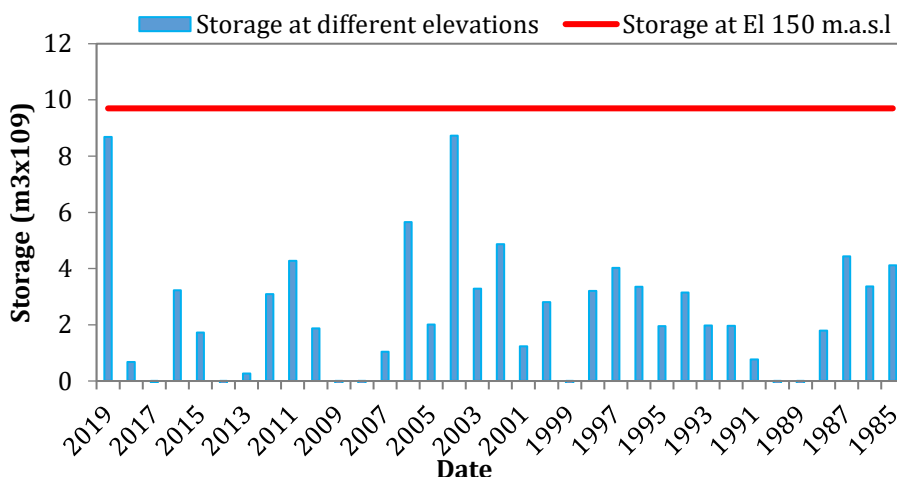

Figure 10. The storage of Haditha Dam from 1985 to 2019.

3.6 Monitoring Ecological and Environmental Data

The sampling from upstream and downstream of Haditha dam was taken twice a month, and the results of the testing were compared with the Iraqi standard (1986), and World Health Organization (WHO) standards (1971) for the maximum permissible level of pollution in surface water as shown in **Table 1 (Sulyman, 2018)**.

Table 1. Results of Ecological and environmental data for the samples taken upstream and downstream of Hadith Dam.

Limiting	IRAQ Standard		World Health Organization (WHO) standard	the sample test of Hadith Dam from 7/1/2020 to 15/12/2020
	Maximum Desired limit	Maximum allowed limit		
Temperature °C	13 – 35	-	13– 35	30
Electrical Conductivity (EC) μ S/cm	1000	-	1000	784
Total dissolved solids (TDS) mg/l	500	1500	1000	560
Total suspended solids (TSS) mg/l	60	-	30	N.A
Turbidity (NTU°)	5	25	1 – 5	N.A
pH	7-8.5	5.2-6	6.5-8.5	7.9
Magnesium (Mg ²) mg/l	50	150	50 –150	29.5
Sodium (Na ⁺)	50	200	Less 200	47
Calcium (Ca ²) mg/l	75	200	200	48
Hardness (T.H) mg/l	100	500	250 -500	225
Nitrate (NO ₃) mg/l	20	40	10	19
Sulfates (SO ₄) mg/l	200	400	400	197
Chloride (Cl ⁻) mg/l	200	600	250	67
Alkaline mg/l	170	200	125	N.A
Fluoride (F) mg/l	N.A	1	0.5 -1.5	N.A
HCO ₃ mg/l	N.A	N.A	N.A	146.4

N.A. means not available.

There are no stranded limits used to assess the value of the tested parameters found in the seepage water collected from the dam body. All the measurements were within the parameters permitted by the Iraqi standard for drinking water and WHO standards, but the value of permitted HCO₃ was not found in both the Iraqi and WHO standards. Some



parameters like Turbidity, Alkaline, Fluoride, and Total suspended solids are not found in the tested parameters of the laboratory for Haditha Dam.

3.7 Frequency of Monitoring

Table 2 summarizes the results for the frequency of monitoring for various parameters while the frequency required for ICOLD the data should be carried out once a week at most of the measuring devices utilizing bar code and portable. In case of data that change slowly this interval is extended to once a month or 4 times a year (**ICOLD, 2000**). For Haditha Dam, the Frequency of settlement is not complied with. There is a period from 2002 to 2009, no readings for the surface point on the dam’s body, and also for the hydroelectric station, and no specific frequency after 2009 the reading was taken twice a year, once, or every two years, or every three years.

Table 2. Frequency of Monitoring for Various Parameters

Type of Measurement	Periodic Report Operation (Frequency of Readings)				
	Regular U.S. Bureau of Reclamation (National Research Council, 1983)	Regular Malaysia Dam Safety Management Guideline (DRIP, 2017)	Regular River Development and Ganga Rejuvenation Government of India (Guidelines for Safety Inspection of Dams,2018)	Regular of New Zealand Dam Safety Guidelines NZSOLD (NZSOLD Safety Guidelines, 2000)	Haditha dam
Piezometers	Monthly	Monthly	Monthly	Monthly	Twice/ Monthly
Pore pressure cells	Monthly	Monthly	Monthly	Monthly	Monthly
Seepage measurement	————	8 times/ month	Monthly	Weekly	Twice /month
Embankment settlement points	Every 2 years	Every 3month	Semi-annual	Annually	Not comply
Joint meters	Every 2 years	Every 3month	Monthly	Annually	Every 3month
Inclinometer and Pendulum	Every 2 years	Every 3month	Monthly	Annually	Every 3month

3.8 The Visual Inspection

According to **Table 4**, followed at Haditha Dam does not according to the standard International required inspection and it followed the procedure recommended by the company that constructed the dam. The visual inspection of cracks and displacement due to horizontal movement and sinkholes should record the location, length, depth, width, alignment, and other pertinent physical features. Also, the working team immediately marks the extent and limit of cracking and often monitors the crack.



Table 4. Categorization of Visual Inspection Followed at Haditha Dam

Location	Visual inspection requirements by New Zealand Dam Safety Guidelines (NZSOLD)	Visual inspection requirements by the International Commission on Large Dams (ICOLD)	Visual inspection current followed Haditha dam	Remark
Downstream face	<ul style="list-style-type: none"> -Alignment (M) -Cracks (M) -Settlements and slides(A) -Erosion -Vegetation (A) -Animal burrows(M) -Human activity (M) -Leakage (W) -Muddy water (W) -Seepage (M) 	<ul style="list-style-type: none"> -Surfacing seepage water, turbidity (W) -Soaked surfaces(W) -Cracks, local settlements, local slides (W) -Erosion (W) -Vegetation(W) -Animal burrows(W) 	<ul style="list-style-type: none"> -seepage water (W) -Erosion, bulging of riprap on the slop(W) -Vegetation (W) -Downstream safety of barrier and stairs and - the condition of the curbstone on the berm (W) 	<p>For Haditha dam no mention of animal burrows or human activity.</p> <p>- Downstream safety of barriers and stairs may include cracks, local settlements, and local slides).</p> <p>-Turbidity and Muddy water are included in the chemical analyses.</p>
Dam crest	<ul style="list-style-type: none"> -Alignment (M) -Settlements and slides(A) -Erosion -Vegetation (A) 	<ul style="list-style-type: none"> -Cracks, local settlements(W) -Erosion(W) -Vegetation(W) -Animal burrows(W) -Condition of the road (W) 	<ul style="list-style-type: none"> -Blocking of water rain manhole(W) -Condition of road pavement, setting of curbs, and safety barriers(W) -Vegetation(W) -Cracks, local settlements(W) 	<p>For Haditha dam no mention of animal burrows</p>
Upstream face	<ul style="list-style-type: none"> -Alignment (M) -Cracks (M) -Settlements and slides(A) -Erosion -Vegetation (A) -Animal burrows(M) -Human activity (M) 	<ul style="list-style-type: none"> -Vortex formation on the water surface(W) -Cracks, local deformations, local slides(W) -Bulging of surface sealing elements(W) -Damages on the surface sealing (W)element(W) -Displacement of riprap -Vegetation(W) -Animal burrows(W) 	<ul style="list-style-type: none"> -Different settlement (W) -Condition of the concrete in the slop and berm(W) -Performance of expansion joint between slabs of the concrete lining and drainage hole (W) -Washing out of embankment material -Blocking of the drainage hole (W) -Vegetation(W) -Floating -bodies(W) 	<p>For Haditha dam no mention of animal burrows and human activity</p>
Drainage system	<ul style="list-style-type: none"> seepage area internal drain relief drainage -Muddy water (M) -Leakage (W) -Deterioration (A) -Alignment (M) -Cracks (M) 	<ul style="list-style-type: none"> Galleries (injection, drainage, shafts, inspection), and adits -Cracks (W) -Condition of concrete(W). -Clogging of drainage system(W) 	<ul style="list-style-type: none"> The drainage system and grout gallery -Vegetation (W) -Condition of relief borehole and wires(W) -Subsidence and heaving of the ground surface(W) -Leak of seepage water(W) 	<p>For Haditha dam Subsidence and heaving of the ground surface may include (alignment and cracks)</p> <p>Turbidity and Muddy water are</p>



		-Leaking seepage water, turbidity(W)	-Removal of soil material from(W)	included in chemical analyses
Abutments	Abutments -Cracks (M) -Settlements and slides(A) -Leakage (W) -Vegetation(A) -Animal burrows(M) -Seepage (M)	Abutments (Contact zones to the dam and dam surrounds) - Surfacing seepage water, boils, turbidity (W) - Soaked surfaces (W) - Cracks, local settlements, local landslides (W) - Erosion (W) - Vegetation (W)	Abutments and territory adjoining the dam Downstream side -Water logging on the ground (W) Heaving on the ground to detect -- upheavals of the ground(W) - Develop a new sinkhole(W) -Condition of dam abutments and bank protective (W) Erosion and deformation(W)	No mention of Vegetation, animal burrows
Reservoir surface	General area (reservoir surfaces shoreline, upstream watershed, Downstream floodplain - Settlements and slides(A) - Leakage (A) -Vegetation(A)	Surround Reservoir (surface, banks and slopes, Downstream area) - Floating debris (W) - Pollution (W) - Settlements and landslides - Cracks (as an indication of slope instability) (W) - Condition of infrastructure - Vegetation (W) - Sinkhole (W) - Boils (W) - Soaked surfaces (W)	Surrounds (Reservoir surface)	No mention of a general area or surrounding for the Haditha dam
Hydraulic structures (spillway, intake, bottom outlet, mechanical and electrical system)	Inlet and outlet, spillway (approach channel, stilling basin, discharge channel, emergency system control features). -Debris (W) -Erosion (M) -Settlements and slides(M) -Vegetation(A) -Deterioration(A) -Leakage (M) -Deterioration (A)	Hydraulic structures (spillway, intake, bottom outlet) -Cracks (W) -Erosion (W) -Scour holes (W) -Downstream (W) -Displacements, or joint movement (W) -Floating debris(W) -Leakages along(W) -conduits, turbidity(W) -Condition and Tightness (W) -Deterioration (A)	Hydroelectric station and facilities -Turbine site -Stilling basin -Bottom irrigation outlets -Service buildings -secondary station (S.I.G)and -tunnels -Oil-Underground storage -All other concrete parts -Dewatering Drainage system -Downstream of the dam for 100m -Road at elevation 100. -mechanical and electrical system	A report is prepared annually between the project department of the Ministry of Water Resources and the department of the Ministry of Electricity

(W) Weekly, (M) Monthly, (A) Annual



4. CONCLUSIONS

The safety of Haditha Dam includes the assessment of the surveillance and monitoring procedures which cover the evaluation of values and frequency of measured parameters including geotechnical, structural, hydrological, and environmental. The geotechnical parameters include settlement, pore water pressure, piezometer level, seepage, and results. From the results obtained from the implementation of the methodology, the following conclusions can be made:

1. The maximum settlement was recorded at the left side of the dam (station 41) and it was found to be 331 mm which is 51% higher than the allowable settlement (219 mm). The frequency of measurement at Haditha Dam does not comply with the international standard.
2. The percentage of maximum recorded value in the pressure cells was found to be 21.57 % and it occurred in cell number 995 which is higher than the allowable limits (113.1 m). The frequency of measurement of pore water pressure was compiled with international standards.
3. Only 17 % of the measured piezometer readings were more than the allowable limits. The frequency of the measurement of piezometer readings was found within that required by international standards.
4. The seepage rates (water flux) are found within acceptable limits while the frequency of measurements has complied with Indian standards and not comply with other standards.
5. The measurements in three locations by joint meters device (D10, D15, D18) exceeded the limits by 62%, and this was recorded at join meter number D18. The frequency of measurements complied with most of the international standards.
6. For both hydrological and environmental parameters, were found within Limits.
7. For visual inspection, no information for mechanical and electrical systems was available. The annual report included only the frequency of visual inspection for mechanical and electrical systems. In addition, no information about the length and depth of the cracks was mentioned in the visual inspection form.

Acknowledgements

The cooperation of the State Commission of Dam and Reservoir, Ministry of Water Resource, Iraq in furnishing the authors with the required data is highly acknowledged. The research was also supported by the Department of Water Resources Engineering, College of Engineering, University of Baghdad.

Credit Authorship Contribution Statement

Alyaa J. Hadi: wrote the original draft while Thamer A. Mohammed edited the draft and wrote the results, discussion, and conclusions.

Declaration of Competing Interest

The authors declare that they have no known competing financial interests or personal relationships that could have appeared to influence the work reported in this paper.



REFERENCES

- Alba, M., Fregonese, L., Prandi, F., Scaioni, M. and Valgoi, P., 2006. Structural monitoring of a large dam by terrestrial laser scanning. *International Archives of Photogrammetry, Remote Sensing and Spatial Information Sciences*, 36(5), P.6.
- Adamo, N., Sissakian, V.K., Al-Ansari, N., Elagely, M., Knutsson, S. and Laue, J., 2018. Comparative study of Mosul and Haditha dams in Iraq: different construction materials contribute to different designs. *Journal of Earth Sciences and Geotechnical Engineering*, 8(2), pp.71-89.
- Adamo, N., Al-Ansari, N., Sissakian, V., Laue, J. and Knutsson, S., 2021. Dam safety: use of instrumentation in dams. *Journal of Earth Sciences and Geotechnical Engineering*, 11(1), pp.145-202. [Doi:10.47260/jesge/1115](https://doi.org/10.47260/jesge/1115).
- Mohammed Ali, A.A.S. and Abed, Z.A.H., 2018. Derivation of operation rule for ilisu dam. *Journal of Engineering*, 24(6). pp.53-71. [Doi:10.31026/j.eng.2018.06.05](https://doi.org/10.31026/j.eng.2018.06.05).
- AL-kanani, Y.H., 2009. *Displacement computation of Mosul dam by using free geodetic network adjustment*. Doctoral dissertation, University of Baghdad, Baghdad, Iraq.
- Al-Shlash, K.T., Ali, E.F. and Alwash, H.H., 2010. Effect of pore water pressure parameters on the stability of Al-Ad'daim earth dam. *Engineering and Technology Journal*, 28(8). [Doi:10.30684/etj.28.8.9](https://doi.org/10.30684/etj.28.8.9).
- Alridha, N.A., Baqir, R.A. and Hamid, A.R., 2012. Seismicity and seismotectonic study for Altunkopri dam site north Iraq. *Iraqi Journal of Science*, 53(3), pp.595-601.
- Alzamily, Z.N. and Sh. Abed, B., 2022. Experimental and theoretical investigations of seepage reduction through zoned earth dam material with special core. *Materials Today: Proceedings*, pp.998-1005. [Doi:10.1016/j.matpr.2021.10.283](https://doi.org/10.1016/j.matpr.2021.10.283).
- Auckland Regional Council. 2012. Dam safety guidelines Guidelines for construction, maintenance, and monitoring. North Island, NewZland. <http://www.aucklandcity.govt.nz/council/documents/technicalpublications/TP109%20Dam%20safety%20guidelines%20introduction.pdf>
- Aufleger, M., Conrad, M., Goltz, M., Perzlmaier, S. and Porras, P., 2007. Innovative dam monitoring tools based on distributed temperature measurement. *Jordan Journal of Civil Engineering*, 1(1), pp.29-37.
- Bashar, K.E., Khudair, B.H. and Khalid, G.K., 2015. Calibration and verification of the hydraulic model for the Blue Nile river from roseires dam to Khartoum City. *Journal of Engineering*, 21(12), pp.46-62. [Doi:10.31026/j.eng.2015.12.04](https://doi.org/10.31026/j.eng.2015.12.04).
- Bonelli, S. and Royet, P., 2001. Delayed response analysis of dam monitoring data. In *ICOLD European symposium on dams in a European context*.
- Borghero, C., 2018. Feasibility study of dam deformation monitoring in Northern Sweden using Sentinel1 SAR interferometry.
- Bukenya, P., Moyo, P., Beushausen, H. and Oosthuizen, C., 2014. Health monitoring of concrete dams: a literature review. *Journal of Civil Structural Health Monitoring*, 4, pp.235-244.
- Charlwood, R., Shiferaw, F., Hattingh, L., Gasmelseed, K.M., Roberts, P., Ghany, H., Asfaw, G. and Isaac, C., 2014. Situational Assessment Report for Dam Safety Management in the Eastern Nile Sub-Basin.



Chen, S., Gu, C., Lin, C., Wang, Y. and Hariri-Ardebili, M.A., 2020. Prediction, monitoring, and interpretation of dam leakage flow via adaptive kernel extreme learning machine. *Measurement*, 166, p.108161.

Cheng, L. and Zheng, D., 2013. Two online dam safety monitoring models based on the process of extracting environmental effects. *Advances in Engineering Software*, 57, pp.48-56

Chouinard, L. and Roy, V., 2006, June. Performance of statistical models for dam monitoring data. In Joint international conference on computing and decision making in civil and building engineering, Montreal, pp. 14-16.

Clarkson, L., Williams, D. and Seppälä, J., 2021. Real-time monitoring of tailings dams. *Georisk*, 15(2), pp.113-127. [Doi:10.1080/17499518.2020.1740280](https://doi.org/10.1080/17499518.2020.1740280).

Dai, B., Gu, C., Zhao, E. and Qin, X., 2018. Statistical model optimized random forest regression model for concrete dam deformation monitoring. *Structural Control and Health Monitoring*, 25(6), p.e2170.

Darbre, G.R. and Proulx, J., 2002. Continuous ambient vibration monitoring of the arch dam of Mauvoisin. *Earthquake engineering & structural dynamics*, 31(2), pp.475-480.

De Membrillera, M.G., Gómez, R. and De la Fuente, M., 2019. Dam monitoring flaws and performance issues: Some thoughts and recommendations. In *Sustainable and Safe Dams Around the World/Un monde de barrages durables et sécuritaires* (pp. 1117-1129). CRC Press.

DOUGLAS, G., 2021, February. Monitoring and instrumentation strategies for new and existing dams. In *Symposium on Sustainable Development of Dams and River Basins*, 24, P. 27.

Fabritius, A., Heinemann, B., Dornstädter, J. and Trick, T., 2017. Distributed fiber optic temperature measurements for dam safety monitoring: current state of the art and further developments. In *Proceedings of the Annual South African National Committee on Large Dams (SANCOLD) Conference, Centurion, Tshwane, South Africa*.

Gaagai, A., Aouissi, H.A., Krauklis, A.E., Burlakovs, J., Athamena, A., Zekker, I., Boudoukha, A., Benaabidate, L. and Chenchouni, H., 2022. Modeling and risk analysis of dam-break flooding in a semi-arid Montane watershed: a case study of the Yabous Dam, Northeastern Algeria. *Water*, 14(5), P.767. [Doi:10.3390/w14050767](https://doi.org/10.3390/w14050767).

Ghali, H.M. and Azzubaidi, R.Z., 2021. Managing the flood waves from Hemrin dam. *Journal of Engineering*, 27(7), pp.42-52. [Doi:10.31026/j.eng.2021.07.04](https://doi.org/10.31026/j.eng.2021.07.04).

Gikas, V. and Sakellariou, M., 2008. Settlement analysis of the Mornos earth dam (Greece): Evidence from numerical modeling and geodetic monitoring. *Engineering Structures*, 30(11), pp.3074-3081.

Glisic, B., Inaudi, D., Kronenberg, P. and Vurpillot, S., 1999. Dam monitoring using a long SOFO sensor. *Proceedings of the Hydropower into Next Century, Gmunden, Austria*, pp.18-20.

Gómez López De Munain, R. and Merino Vidruero, J., 2012. Dam safety monitoring to assess val dam behavior. *Zaragoza*, 23, P.25.

González-Aguilera, D., Gómez-Lahoz, J. and Sánchez, J., 2008. A new approach for structural monitoring of large dams with a three-dimensional laser scanner. *Sensors*, 8(9), pp.5866-5883. [Doi:10.3390/s8095866](https://doi.org/10.3390/s8095866).

DRIP, 2017. Guidelines for Instrumentation of Large Dams. New Delhi. Dam Safety Rehabilitation Directorate. NewDelhi, India



Hossein, S., Etemadifar, M. and Aghamolaie, I., 2017. Monitoring of Masjed Soleyman dam based on instrumentation data. *International Journal of Innovative Science, Engineering & Technology*, 4(5), pp.78-99.

Khalaf, Y.H., Abdulateef, N.A. and Salman, A.D., 2018. Computation of deformation in networks geodetic by least squares method and ellipse of errors. *Association of Arab Universities Journal of Engineering Sciences*, 25(3), pp.100-109.

ICOLD Bulletin, 2020. General principles and framework for dam safety, ICOLD, Paris, France.

ICOLD, 2018. Dam Surveillance Guide Guide De La Surveillance Des Barrages. [Online] Available At: <http://www.icold-cigb.org/>.

ICOLD-B118,2000. Automated-dam-monitoring-systems-Guidelines, ICOLD, Paris, France. Available at: <https://www.scribd.com/document/517382132/ICOLD-B118>.

Jänichen, J., Schmullius, C., Baade, J., Last, K., Bettzieche, V. and Dubois, C., 2022. Monitoring of radial deformations of a gravity dam using sentinel-1 persistent scatterer interferometry. *Remote Sensing*, 14(5). [Doi:10.3390/rs14051112](https://doi.org/10.3390/rs14051112).

Jensen, J. and Leijström, M., 2022. Use of Digital Image Correlation for monitoring of concrete buttress dam failure model tests, Department of Civil and Architectural Engineering Division of Concrete Structures Stockholm, Sweden.

Johansson, S., 1997. *Seepage monitoring in embankment dams* (Doctoral dissertation, Institutionen för anläggning och miljö). Department of Civil and Environmental Engineering Royal Institute of Technology S-100 44 Stockholm, Sweden.

Kale, Ö.A., Aşikoğlu, Ö.L. And Baradan, S., 2022. Evaluation of Occupational Safety in the Operation and Maintenance Activities of Dams. *Teknik Dergi*, 33(5), pp.12709-12724.

Kibler, K.M., Tullos, D.D. and Kondolf, G.M., 2011. Learning from dam removal monitoring: challenges to selecting experimental design and establishing the significance of outcomes. *River Research and Applications*, 27(8), pp.967-975.

King, L.M. and Simonovic, S.P., 2020. A deterministic Monte Carlo simulation framework for dam safety flow control assessment. *Water*, 12(2), P.505.

Li, T., Motagh, M., Wang, M., Zhang, W., Gong, C., Xiong, X., He, J., Chen, L. and Liu, J., 2019. Earth and rock-filled dam monitoring by high-resolution X-band interferometry: Gongming dam case study. *Remote sensing*, 11(3), p.246.

Lin, P., Li, Q., Fan, Q. and Gao, X., 2013. Real-time monitoring system for workers' behavior analysis on a large-dam construction site. *International Journal of Distributed Sensor Networks*, 9(10), p.509423.

Loperte, A., Bavusi, M., Cerverizzo, G., Lapenna, V. and Soldovieri, F., 2011. Ground penetrating radar in dam monitoring: The test case of Acerenza (Southern Italy). *International Journal of Geophysics*, 2011. [Doi:10.1155/2011/654194](https://doi.org/10.1155/2011/654194).

Luzi, G., Crosetto, M. and Monserrat, O., 2010. Advanced techniques for dam monitoring. In *Proceedings of the 2nd International Congress on Dam Maintenance and Rehabilitation*, Zaragoza, Spain, pp. 23-25.



- Mahdi, A. and Rezouki, S., 2017. Developing a management system for assessing dam safety in Iraq. *Journal of Garmian University*, 4(4), pp.409–427. <https://doi.org/10.24271/garmian.221>.
- Mainali, G., Nordlund, E., Knutsson, S. and Thunehed, H., 2015. Tailings dam monitoring in Swedish mines using self-potential and electrical resistivity methods. *Electronic Journal of Geotechnical Engineering*, 20(13), pp.5859–5875.
- Marini, P.P., Baldoni, P., Farina, F., Cortezzi, F. and Masera, A., 2004. Ridracoli dam: surveillance and safety evaluation report on the internet page. In Long-term benefits and performance of dams: Proceedings of the 13th Conference of the British Dam Society and the ICOLD European Club meeting held at the University of Kent, Canterbury, UK from 22 to 26 June 2004., pp. 247-255.
- Milillo, P., Perissin, D., Salzer, J.T., Lundgren, P., Lacava, G., Milillo, G. and Serio, C., 2016. Monitoring dam structural health from space: Insights from novel InSAR techniques and multi-parametric modeling applied to the Pertusillo dam Basilicata, Italy. *International journal of applied earth observation and geoinformation*, 52, pp.221-229.
- Monteiro-Alves, R., Toledo, M., Moran, R. and Balairón, L., 2022. Failure of the downstream shoulder of rockfill dams due to overtopping or throughflow. *Water (Switzerland)*, 14(10). <https://doi.org/10.3390/w14101624>.
- Government of Malaysia, 2017. *Malaysia Dam Safety Management Guidelines (My dams)*. Kuala Lumpur, Malaysia. Available at: https://www.water.gov.my/jps/resources/PDF/MyDAMS_2017_%28Free_Copy%29.pdf
- National Research Council, 1983. *Safety of existing dams: Evaluation and improvement*. National Academies Press. United States of America.
- Nordström, E., Malm, R., Blomdahl, J., Tornberg, R. and Nilsson, C.O., 2015. Optimization of dam monitoring for long concrete buttress dams. In *ICOLD Symposium*, 13-20 June, Stavanger, Norway.
- NZSOLD, 2000. Regular of New Zealand Dam Safety Guidelines, *Appendix A*. The New Zealand Society on Large Dams, New Zealand -Available at <https://nzsold.org.nz/wp-content/uploads/2019/10/NZSOLD-Safety-Guidelines-2000.pdf>.
- Pereira, S., Magalhães, F., Gomes, J.P., Cunha, Á. and Lemos, J.V., 2018. Dynamic monitoring of a concrete arch dam during the first filling of the reservoir. *Engineering Structures*, 174, pp.548-560.
- Peres, F.F., Scheer, S. and de Faria, É.F., 2018. A taxonomy of tasks in dam cracks surveillance for augmented reality application. *International Journal of Advanced Engineering Research and Science*, 5(10), p.266169.
- Pipitone, C., Maltese, A., Dardanelli, G., Lo Brutto, M. and La Loggia, G., 2018. Monitoring water surface and level of a reservoir using different remote sensing approaches and comparison with dam displacements evaluated via GNSS. *Remote Sensing*, 10(1), P.71.
- Pytharouli, S.I. and Stiros, S.C., 2005. Ladon dam (Greece) deformation and reservoir level fluctuations: evidence for a causative relationship from the spectral analysis of a geodetic monitoring record. *Engineering Structures*, 27(3), pp.361-370.
- Qiu, Z., Jiao, M., Jiang, T. and Zhou, L., 2020. Dam structure deformation monitoring by GB-InSAR approach. *IEEE Access*, 8, pp.123287-123296.
- Rahmati, O., Kalantari, Z., Samadi, M., Uuemaa, E., Moghaddam, D.D., Nalivan, O.A., Destouni, G. and



- Tien Bui, D., 2019. GIS-based site selection for check dams in watersheds: considering geomorphometric and topo-hydrological factors. *Sustainability*, 11(20), P.5639.
- Reguzzoni, M., Rossi, L., De Gaetani, C.I., Caldera, S. and Barzaghi, R., 2022. GNSS-based dam monitoring: the application of a statistical approach for time series analysis to a case study. *Applied Sciences (Switzerland)*, 12(19). <https://doi.org/10.3390/app12199981>.
- Sadiq, A.M. and Albusoda, B.S., 2020. Experimental and theoretical determination of settlement of shallow footing on liquefiable soil. *Journal of Engineering*, 26(9), pp.155–164. <https://doi.org/10.31026/j.eng.2020.09.10>.
- Seyed-Kolbadi, S.M., Hariri-Ardebili, M.A., Mirtaheri, M. and Pourkamali-Anaraki, F., 2020. Instrumented health monitoring of an earth dam. *Infrastructures*, 5(3). <https://doi.org/10.3390/infrastructures5030026>
- Srivastava, A., 2011. *Geotechnical Instrumentation, monitoring, and Surveillance in Earth Dam Safety Program Geotechnical Instrumentation*, [online] Available at: <https://www.researchgate.net/publication/266602019>.
- Sulyman, M. (2018)/ *Sustainable Resources Management*, 3(2) 67-78 <http://doi.org/10.5281/zenodo.1302032>.
- Sunantyo, T.A., Basah, S.K., Fakrurazzi, D., Adin, S., Adhi, D. and Susilo, A., 2012. Design and installation for dam monitoring using multi sensors: a case study at Sermo dam. *Yogyakarta Province, Indonesia, FIG Working Week*.
- Supakchukul, U., Laungnarutai, W., Jintanakorn, P., Brohmsubha, P., Raphitphan, N., Suwatthikul, J. and Vanijjirattikhan, R., 2019, September. Automatic dam safety evaluation. In *2019 58th Annual Conference of the Society of Instrument and Control Engineers of Japan (SICE)* (pp. 785-790). IEEE
- The State Commission of Dams and Reservoirs, 2020. *Technical report for Haditha Dam*. Ministry of Water Resources, Baghdad, Iraq.
- Vincent, E., Emeka, O.M. and Dominic, P., 2020. Dam and its Failure: *A Brief Review of some selected Dams around the World*. *Adamawa State University Journal of Scientific Research*, [online] 8. Available at: <http://www.adsujr.com>.
- Wang, J., Sheng, Y. and Tong, T.S.D., 2014. Monitoring decadal lake dynamics across the Yangtze Basin downstream of Three Gorges Dam. *Remote Sensing of Environment*, 152, pp.251-269.
- Zainal, A.K.E., 2003. *Two-Dimensional Consolidation Analysis of Partially Saturated Soils By Using the Finite*. 14(February), pp.2232–2255.