



TRANSMISSION OF A MULTIPLEXED EIGHT CHANNELS SUBCARRIER OPTICALLY INTENSITY MODULATED BASED ON MICROCONTROLLER.

Husam A. Mohammed
Baghdad University\ College of
Engineering\ Elec. & Comm. Dep.

Hani J. Kbashi
Baghdad University\ College of
Science\
Physics Department.

ABSTRACT

An optical fiber communication system for transmitting eight time division multiplexed analog signals each of bandwidth of 500 Hz was designed and implemented. The system utilizes the 8051 microcontroller as a parallel to serial converter in the transmitter side and parallel to serial converter in the receiver side in addition to the control process of the multiplexer and demultiplexer in both sides and for serial transmission via its RS232. The transmitted signal is subcarrier intensity modulated using the Amplitude Shift Keying (ASK) modulation technique with a carrier of 20 MHz. A laser diode of the type HFCT-5205 at 1300 nm wavelength was used as an optical carrier generator with an emitted optical power of -10 dBm, and a HFCT-S205 InGaAs/InP PIN Photodiode with responsivity of 0.36 A/W at the receiver side. A single mode fiber of (42 km) length was used as a transmission channel. This system can be utilized in the TDM fiber telephone lines often operating at higher rates such as T3 (44.7 Mbps), T3C (91 Mbps) and above.

إرسال ثمان قنوات ممتزجة بطريقة تضمين الشدة للناقل الثانوي مستنداً على المسيطر الدقيق

الخلاصة

تم تصميم و بناء منظومة اتصالات الليف البصري لإرسال ثمان اشارات تماثلية باستخدام تقنية التجميع بالتقسيم الزمني (TDM). المنظومة تستفيد من المسيطر الدقيق 8051 كمحول من التوازي الى التوالي في جهة المرسل و محول التوالي الى التوازي في جهة المستلم بالاضافة الى عملية السيطرة على الجمع (multiplexer) و الموزع (demultiplexer) في الجهتين و للإرسال التوالي عبر RS232.

تم تضمين الاشارة المرسله بواسطة تضمين ازاحة السعة (ASK) مع تردد حامل 20 MHz. استعمل ليزر داوود من النوع HFCT-5205 ذو طول موجي 1300 nm و قدرة ضوئية مشعة -10 dBm في المرسل و كاشف

ضوئي من النوع InGaAs/InP HFCT-s205 ذو استجابة 0.3 A/W في المستلم. استعمل الليف البصري احادي النمط بطول 42km كقناة ارسال. يتم الاستفادة من المنظومة في بدالات الهاتف الضوئية و عادة تعمل بمعدلات اعلى مثل $T3 (44.7 \text{ MHz})$ و $T3c (91 \text{ MHz})$ وفوق.

KEY WORD

Optical communication system, Microcontroller, Subcarrier optical Intensity modulation.

INTRODUCTION

Everywhere on this planet hair-thin optical fibers carry vast quantities of information from place to place. The use of light as communication methods can date back to antiquity if we define optical communications in a broader way [Govind 2002]. People had used mirrors, fire beacons, or smoke signals to convey a single piece of information. The modern fiber-optic communications started around 1970s when GaAs semiconductor laser was invented and the optical fiber loss could be reduced to 20 dB/km in the wavelength region near $1\mu\text{m}$ [Govind 2002]. Since then, fiber-optic communication has rapidly developed. The enormous progress of lightwave systems can be grouped into several generations. A widely used figure of merit is the bit rate-distance product, BL , where B is the bit rate and L is the repeater spacing [Govind 2002].

The digital optical fiber link mainly consists of a transmitter, fiber transmission medium, and receiver [Govind 2005]. The transmitter converts incoming binary data to on-off light pulses, which are launched into the fiber. At the receiver, the optical stream is detected and converted back into electrical signal.

The laser diode is a preferred source for moderate band to wideband systems. It offers a fast response time (typically less than 1 ns), has a narrow optical bandwidth (as a rule less than 1 nm) and can couple high levels of useful optical power (usually several milliwatts) into an optical fiber with small core and small numerical aperture [Donald & Gerd 1985, Paul 1985].

Generally only the photodetector and its load which usually form the first stage of the gain are uniquely related to the fiber optics, the remaining portion of the receiver is conventional electronics [Donald & Gerd 1985].

Before 1970, such a link could not have been used for transmission over distances greater than a few hundred meters, because of rapid signal attenuation in the fiber [Donald & Gerd 1985]. In that year however, Corning Glass achieved a breakthrough by producing a fused silica (SiO_2) fiber with loss low enough (20 dB/km) to make transmission lengths of a few kilometers commercially practical. This events coupled with the development of semiconductor light sources at about the same time, stimulates a worldwide building of lightwave research and development continues today. Attenuation coefficients of 0.15 dB/km at 1550 nm [Tatsuya1988] and 0.6 dB/km at 1300 nm have been achieved.

In virtually all optical fiber systems only two types of devices are employed for detection. These are either PIN photodiode or Avalanche PhotoDiode (APD). The PIN detector is preferred because it requests no complicated control circuitry, uses much lower DC bias voltage, and has no excess noise mechanism when compared to an APD [Donald&Gerd 1985].

The optical link can operate at an acceptable low error rate only if the optical power at the receiver exceeds some minimum level P_R called the receiver sensitivity. The maximum loss limited transmission distance L_{max} is given by [Govind 2002, Max & Kang 1996]

$$L_{max} \alpha = P_T - P_R - L_c - \text{splice loss} - \text{margin} \quad [1]$$

Where P_T is the transmitted power, α is the fiber attenuation expressed in dB/km, L_c is the connector losses usually taken as 1 dB, and the system margin usually taken between 3-10 dB.

This relationship implies that L_{max} is relatively sensitive to change in the fiber attenuation, but is only weakly dependent on the transmitted power and receiver power. So increasing the transmitter power by order of magnitude, increases L_{max} by only about 20 percent [Donald&Gerd 1985].

In designing an optical communication system it is necessary to consider the limits on the performance of the system set by the Signal to Noise Ratio SNR [1, Paul 1985]. The main noise sources that affect the performance of the optical fiber communication system are:

1. the thermal noise which results due to the load resistance R_L . It may be calculated as follows [Govind 2002, Max & Kang 1996]

$$i_{th} = \sqrt{\frac{4KT\Delta f}{R_L}} \quad [2]$$

where K is the Boltzman constant, T is the temperature in Kelvin, and Δf is the bandwidth.

2. the shot noise which is a combination of the dark current noise i_d and the quantum noise current, it is given by [Govind 2002, Max & Kang 1996]:
- 3.

$$i_{shot} = [q\Delta f(i_s + i_d)]^{1/2} \quad [3]$$

where q is the electron charge, and i_s is the signal current generated due to the incident optical power in the optical detector which is equal to:

$$i_s = p_i R \quad [4]$$

where p_i is the incident optical power and R is the responsivity of the optical detector.

The SNR for the PIN photodiode receiver may be calculated as in below [Max & Kang 1996]

$$SNR(dB) = 20 \log \left(\frac{i_s}{i_{th} + i_{shot}} \right) \quad [5]$$

The performance criterion for digital receiver is governed by the bit error rate BER, defined as the probability of incorrect identification of a bit by the decision circuit of the receiver [Govind 2002]. A commonly optical receiver requires $BER \leq 1 * 10^{-9}$ [Donald & Gerd 1985].

The BER with the optimum setting of the decision threshold is obtained as in follows [Max & Kang 1996]:

$$BER = \frac{\exp(-SNR)}{\sqrt{2\pi SNR}} \quad [6]$$

The receiver sensitivity is then defined as the minimum average received power P_{rec} required by the receiver to operate at a BER of 10^{-9} .

SYSTEM DESCRIPTION

A block diagram of the implemented system is shown in Figure 1. Eight analog signals are generated each at 500 Hz frequency. These signals are time division multiplexed. Multiplexing provides a mechanism to share the use of a common channel by two or more users. TDM interleaves bits or groups of bits (word or characters) belonging to different messages prior to transmission. As such, its original development was based on economics. The advantages in the use of pulse modulation with the Time Division Multiplexing TDM include the fact that the circuitry required is digital. Thus, offering high reliability and efficient operation.

The selection of the required channel is accomplished under the control of the microcontroller (8051) by the software. The sampling rate is about 8 kHz which is the Nyquist rate (Eight channels each with 500 Hz $(8*0.5)*2 = 8\text{kHz}$). The selected sample then converted into a digital signal by the Analog to Digital Converter (ADC). The ADC action is controlled by the software of the microcontroller. The generated data is then fetched by the microcontroller for further process.

The microcontroller controls the whole operation of multiplexing and analog to digital data conversion. In addition, it acts as a parallel to serial converter. It converts the data generated by the ADC into a serial stream and transmitting it through the RS-232 of the microcontroller asynchronously, so that, there is no need for encoding the data stream for the clock and data recovery at the receiver side. By this, the complexity of the system is reduced and the system becomes more flexible. The flow chart of the program of the microcontroller used in the transmitter is shown in the Figure (2).

The transmission of data over the RS 232 of the microcontroller was 100 kbaud. The serial stream then was amplitude shift keying modulated (ASK) with a carrier of 20 MHz.

The ASK modulated signal is used to modulate a laser diode with intensity modulation type. The laser diode was with an operating wavelength of $1.3 \mu\text{m}$, a power of 0.1 mW is launched into the fiber at the high level voltage. The fiber used for guidance of the optical signal is a single mode fiber with attenuation of 0.6 dB/km and length of 42 km that consists of ten pieces of optical fiber each with 4.2 km length. So the length was changed from 4.2 km to 42 km with a 4.2 km step. Each piece was connected with the neighboring one by a splice. The loss of each splice was 0.03 dB and measured by using the Optical Time Domine Reflectrometer (OTDR).

The optical signal at the receiver is detected and converted into electrical signal. A block diagram of the optical receiver is shown in the Figure (4). A PIN photodiode is used in the work with a responsivity of 0.36 A/W at $1.3 \mu\text{m}$.

The detected signal is then demodulated. The reconstructed signal is then passed to the microcontroller serially via its RS-232 port. Here the microcontroller first converts the serially received bit stream into a parallel fashion and controls the



operation of demultiplexing and digital to analog conversion by the software of the receiver which is shown in the Figure (3). Then the pulses belonging to the individual messages are separated and routed to their appropriate destinations.

RESULTS AND DISCUSSION

The main test achieved on the implemented system was measuring the received optical power for different fiber length from which the calculations of the bit error rate were done. A plot which relates the SNR to the BER is shown in the Figure (6). BER was calculated using equation 6. The power budget calculations showed that the maximum length of the optical fiber can be 78.2 km. Where the safety margin was taken to be equal to 6 dB.

CONCLUSION

The suggested system operates properly with acceptable BER. The BER varies with SNR parameter. The BER improves as SNR increases and becomes lower than 10^{-9} for SNR >14.

REFERENCES

- Donald H. Rice, Gerd E. Keiser, 1985, "Applications of fiber optics to tactical communication systems", IEEE Communication Magazine, May, V-23, N-5.
- Govind P Agrawal, 2002, "Fiber Optic Communication Systems", third edition, Willy interscience.
- Govind P. Agrawal, 2005, "Light Wave Technology Telecommunication Systems", Willy interscience.
- James M.R. 1997. "Microcontrollers Cookbook PIC & 8051", first edition, Newnes.
- Max Ming-Kang Lu, 1996, "Principles and Applications of Optical Communication", IRWIN.
- Paul S. Henry, 1985, "Introduction to Lightwave Transmission", IEEE Communication Magazine, May, V-23, N-5.
- Tatsuya Kimura, 1988, "Factors Affecting Fiber Optic Transmission Quality", Journals of Lightwave Technology, May, V-6, N-5.

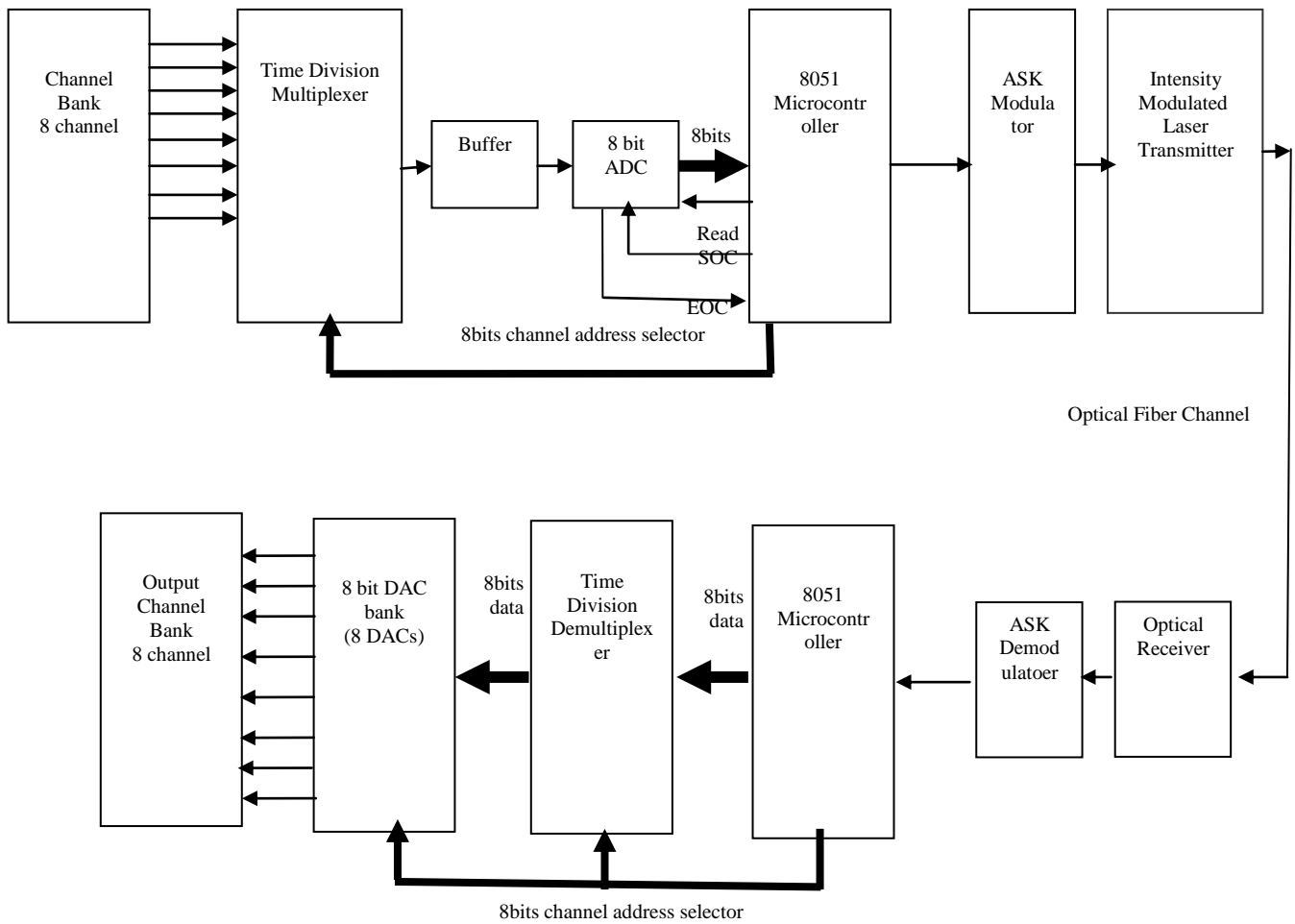

Figure (1): A block diagram of the 8 channel time division multiplexed ASK subcarrier intensity modulated optical fiber communication system

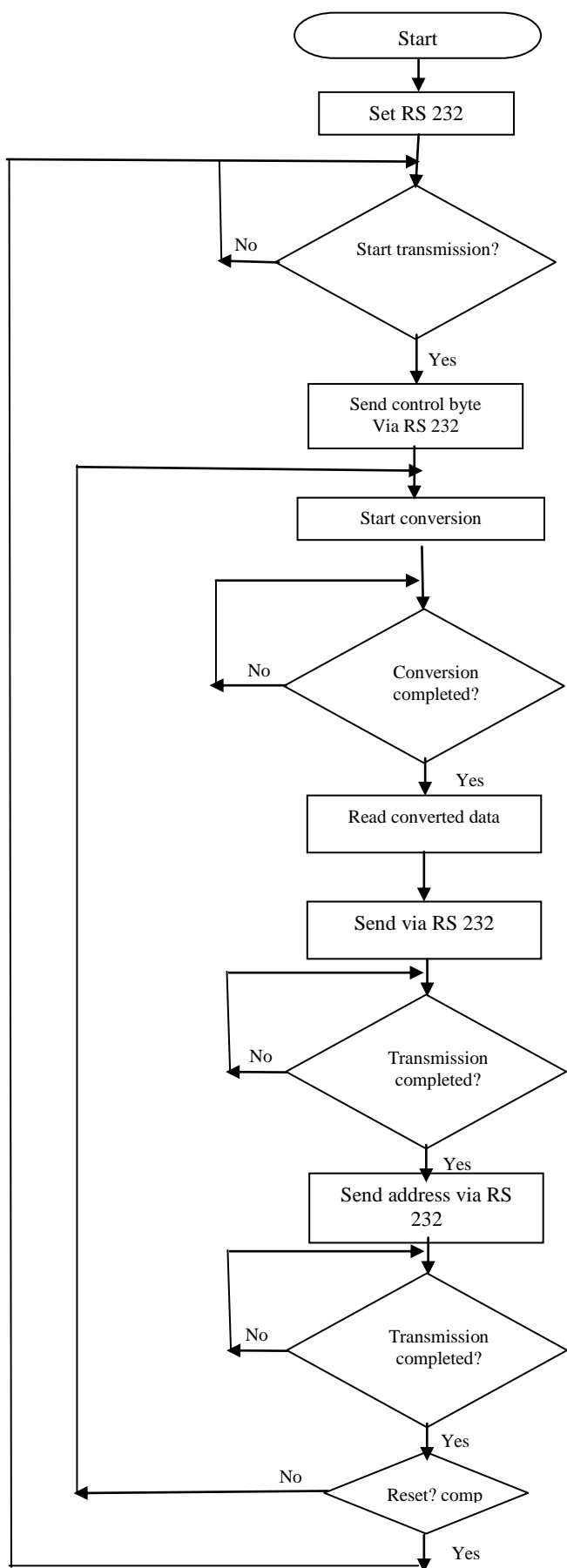
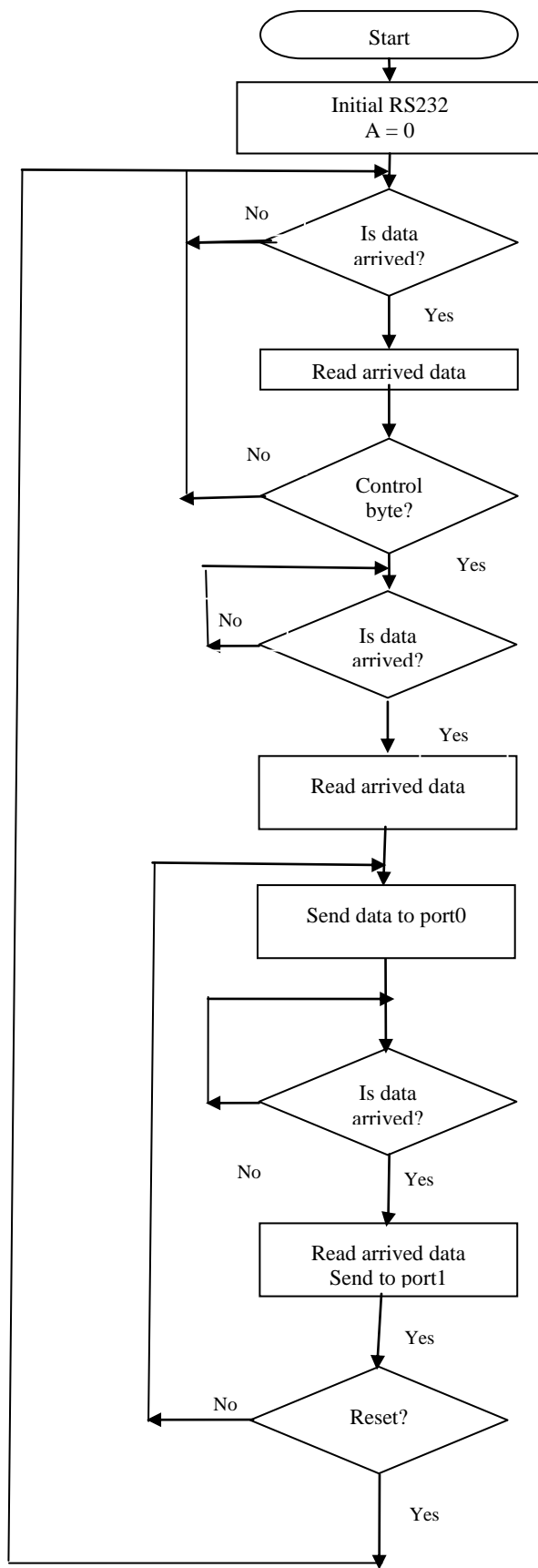

Figure (2): the software program of the transmitter unit



Figure(3): the software program of the receiver unit

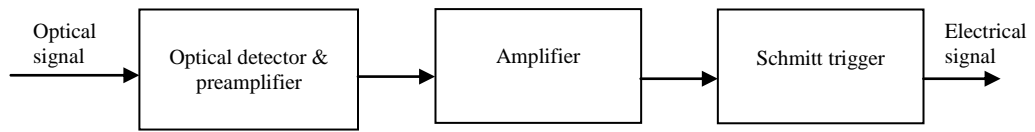

Figure (4): A block diagram of the optical receiver

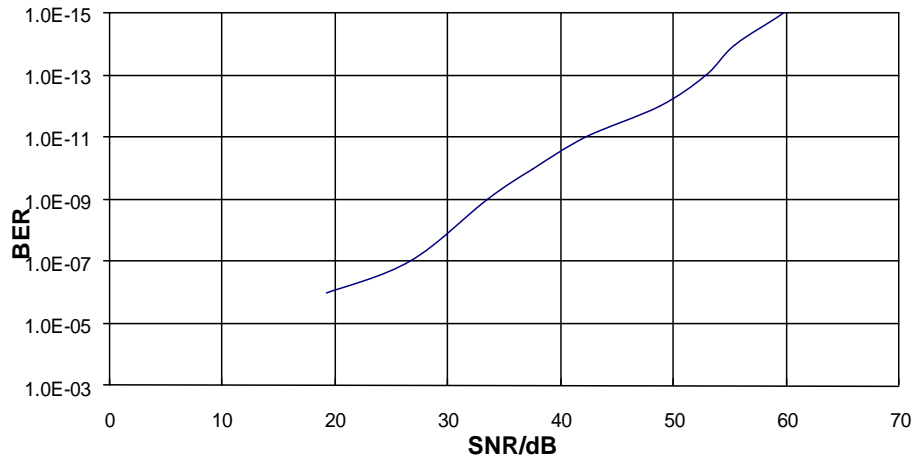

Figure (5): BER versus SNR