



RADAR PARAMETER GENERATION TO IDENTIFY THE TARGET

W.A. Mahmoud , A.K. Sharief and F.D.Umara

University of Baghdad
Baghdad , Iraq

ABSTRACT

Due to the popularity of radar , receive often “ hear “ a great number of other transmitters in addition to their own return merely in noise . The dealing with the problem of identify and / or separating a sum of tens of such pulse trains from a number of different sources are often received on the one communication channel. It is then of interest to identify which pulses are from which source , based on the assumption that the different sources have different characteristics .This search deals with a graphical user interface (GUI) to generate the radar pulse in order to use the required radar signal in any specified location .

الخلاصة :

بسبب شعبية الرادار , المستقبلات غالبا تسمع عدد كبير من مراسلات اخرى بالاضافة الى الضوضاء الراجعة فقط منها . التعامل مع مشكلة تعريف او فصل جمع من عشرات من هذه الحزم النبضية من عدد مختلف المصادر غالبا يتم استلامه في قناة اتصال واحدة . وهذا الاهتمام منصب لتعريف اي نبضات من اي مصدر على اساس افتراض كون المصادر المختلفة لها خصائص مختلفة . هذا البحث يستخدم GUI لتوليد النبضة الرادارية لغرض توليد الاشارة الرادارية المطلوبة في اي موقع محدد .

KEY WORDS

Identification : Target ; Electronic ; Warfare ; Radar Pulse ; graphical User Interface(GUI).

INTRODUCTION

The continuous growth of air traffic increase demand to determine reliable algorithms and systems to tell where , on what altitude and how fast an aircraft is moving , as well as whether that aircraft of interest is friendly . foe or neutral . In general , this is referred to as a tracking . When something is under tracking , it implies that the current object is a target . In the sequel , tracking can be defined more precisely “ as processing measurements obtained from a target in order to maintain an estimate of its current state , which typically consists of kinematics components (such as position , velocity , acceleration etc.) and other components (radiated signal strength m spectral characteristic , feature information etc.) Emphasis of the word “state “ implies that scientists in tracking field are mainly concentrated in estimating the trajectory of the target .The use of the word ‘state ‘ is ambiguous , exact meaning depend always on the context [Hau00].

Defense systems dealing with tracking are important in the warfare because the present aircraft and vessels may be quick and destructive . Therefore m tracking systems are required to be as highly intelligent as possible .Software package presented in this paper comprehends GUI[Alb03] to achieve more reliability in tracking system in order to solve a given problem e.g. the identification problem .

This paper is organized as follows : The principles of the target tracking and the electronic warfare system are presented in section 2 , and section 3, respectively . While the receiving system and the radar signal description are presented in section 4 and section 5 . respectively. The parameters to be identified and the simulated results are presented in section 6and section 7. Respectively, finally the conclusion is represented in section 8 followed by the references.

TARGET TRACKING

In the civilian aviation the target’s velocity , height , position and heading can be easily solved . because all targets are cooperative by default . When dealing with defense applications, qualities listed above are not enough . In fact , they are not even considered first . In the military field , the most urgent is to know whether the targer of interest is friendly or hostile . After then questions as “What is the type of the target ?” and “What is the target threatening ?” rise .Problem that deals with the type of the target is referred to as an identification problem . An example of tracking system , with using

identification network (Bayesian network) in association , is illustrated in Fig.(1) [Vac93]

The identification procedure is as follows ; Targets emit signals, which can be detected sensors , when a sensor has detected a signal , it will be modified and transmitted to the identification system .Then identification system processes all observations and results a type probability function , which is returned to the operator. An example of the identification system is illustrated in Fig.(2).

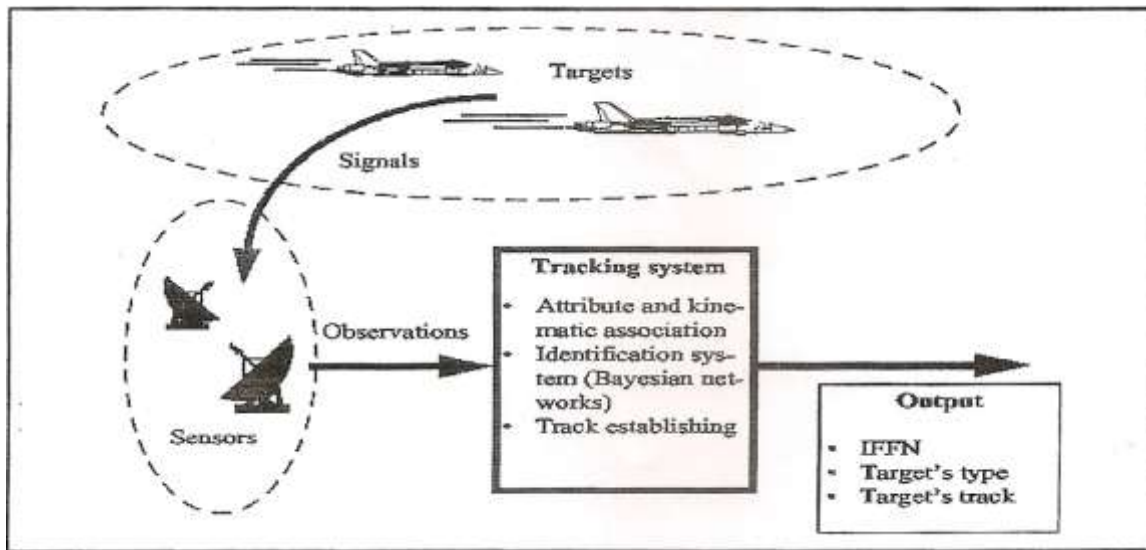

Fig (1) : Illustration of a tracking system

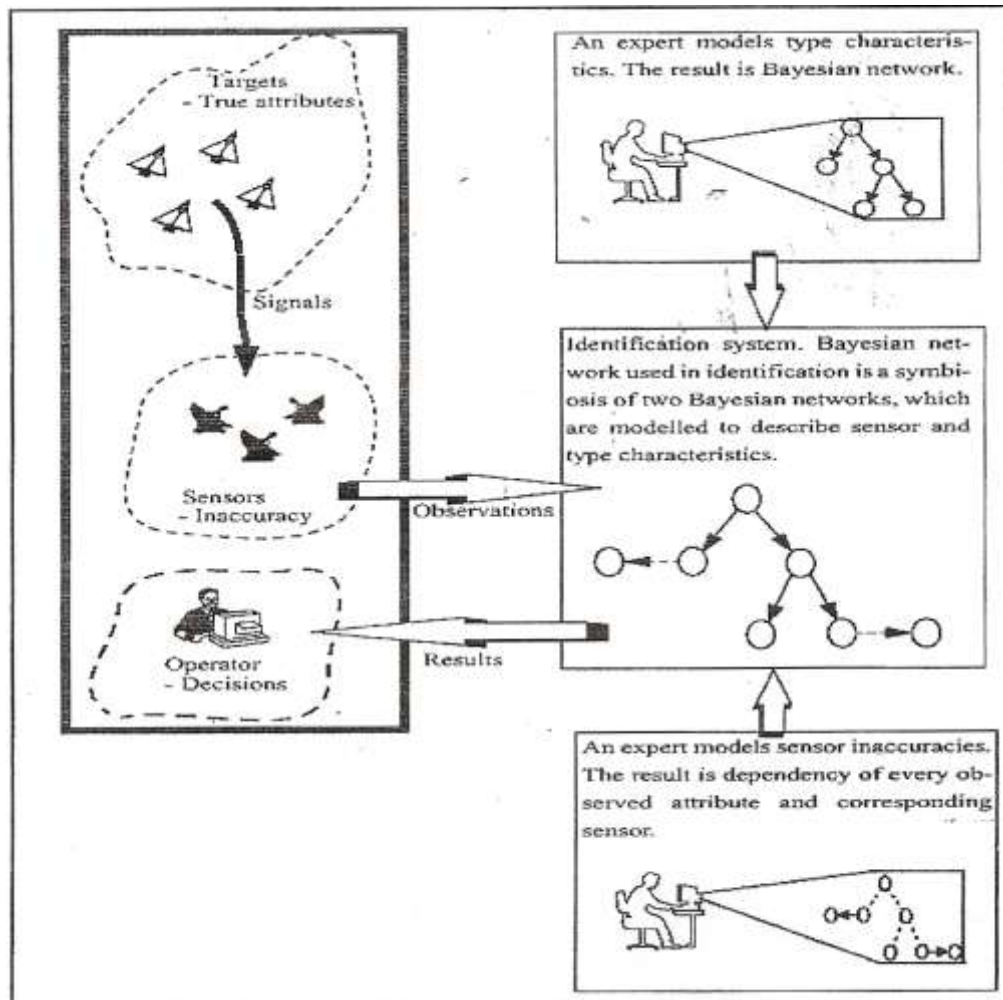

Fig. (2) illustration of the identification procedure .

ELECTRONIC WARFARE SYSTEM

Electronic warfare (EW) receivers will be the assumed approach . It takes many distinct forms , such as detecting and degrading the performance of a hostile radar , intercepting and disrupting enemy communications , decoying aircraft and ordinance and confusing the enemy's perception of the tactical area . It represents a necessary investment to protect friendly weapon platforms [Tsu86].

The basic concept of EW , is to exploit the enemy's electromagnetic emission in all parts of the electromagnetic spectrum in order to provide intelligence on the enemy's order of battle, intentions and capabilities , and to use countermeasures to deny effective use of communications and weapons system while protecting one's own effective use of the same spectrum [Tsu86] .

The modern concept of EW as a vital and basic elements of military strategy , which when used in concert with other military assets , provides a method of neutralizing an enemy force (force divider effect) while simultaneously enhancing the power of a friendly force(force multiplier effect). Thus EW is defined as a military action involving the use of electromagnetic energy to determine, exploit , reduce , or prevent hostile use of the electromagnetic spectrum and action which retains friendly use of the electromagnetic spectrum .FIG. (3) illustrates the functions performed in a modern tactical EW system .

Electronic warfare systems are used in military actions to protect resources from enemy threats . In EW , as in other electronic system , simulation plays a vital role in training the operators to become proficient in using the equipment and recognizing threats . These systems can be organized into the three major categories or divided into three parts:

- Electronic Support Measure (ESM) , which collects information on the electronic environment .
- Electronic Countermeasures (ECM) , trying to disturb enemy systems .
- Electronic Counter-Countermeasures (ECCM) , trying to disturb the enemies ECM [Tsu86].

The ESM and ECCM are referred to as passive systems because they do not radiate electromagnetic energy , while the ECM is energy , EW encompasses the two major areas : ESM and ECM s [Fan01].

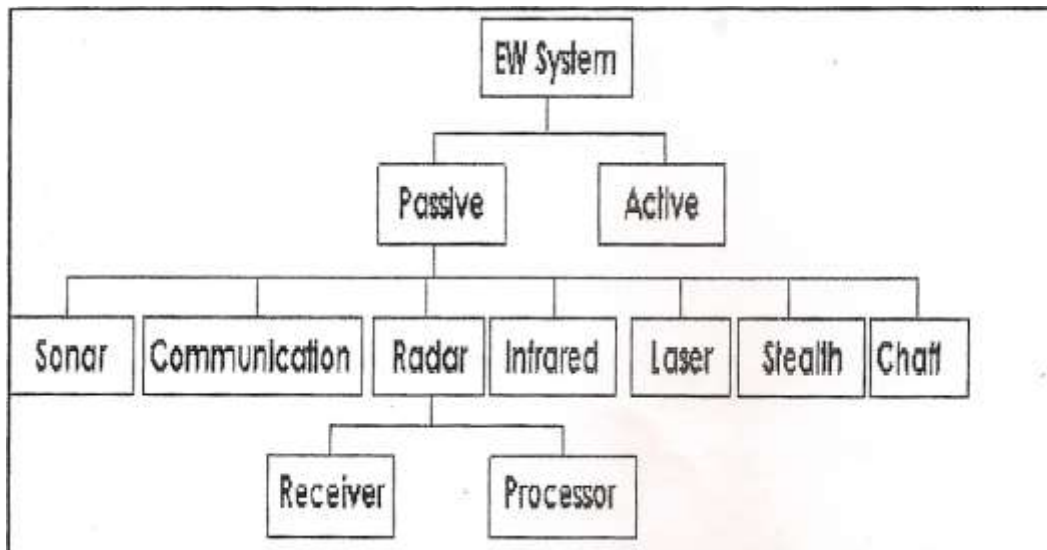

Fig. (3) Functional structure of EW system.

ELECTRONIC WARFARE RECEIVING SYSTEM

A Simplified Block Diagram Of An Ew Receiving System Is Shown In Fig. (4). The First Block Is The Feature Extractor , Which Represents The Radio Frequency Receiver Hardware , The Parameter Measurement And Encoding Circuitry .

Figure(5) Shows A Diagram Of The Digital Receiver . The Output Of The Feature Extractor Is A Pulse Descriptor Word (Pdw) , Which Contains Of Feature Values Of The Intercepted Signal (I.E., Frequency , Amplitude , Pulse Width , Time Of Arrival (In Some Cases) The Signal's Azimuth And Elevation Bearing) .

The Pdw For Each Intercepted Signal Is Stored In A Pulse Buffer For Further Processing . Modern Ew Receiving System Must Operate In An Increasingly Dense Signal Environment. . Hence , A Large Quantity And Jumble Of Signals Are Intercepted That Must Somehow Be Stored In A Timely And Efficient Manner So That Subsequent Actions , Such As Identifying The Signal's Origin , Can Be Taken . The Third Block Performs The Sorting Or Deinterleaving Function By Clustering The Incoming Radar Pulses In To Groups . In Principle , Each Group Or Cluster Should Represent A Single Radar Or Emitter .

However , The Task Of Isolating A Particular Signal From A Specific Emitter Can Be Different To Accomplish , Since The Parameter Boundaries Between Different Signals May Overlap , And Since Factors Such As Measurement Error Can Cause The Measured Characteristics Of The Signal To Become Inexact Or “ Fuzzy “ . A Proper Choice Of The Signal Parameters That Are Used For Sorting As Well As A Proper Assignment Of Their Relative Importance In The Decision Process Can Minimize Some Of The Problems Caused By Inexact Or Ambiguous Signal Characteristics . For Example , One Example , One Signal Parameter That Can Be Very Useful For Signal Sorting Or Deinterleaving Purposes Is The Direction Of Arrival (Doa) Of The Intercepted Signal . Unfortunately , This Parameter May Not Always Be Available , Since Many Ew Systems Cannot Measure A Signal's Doa . Moreover , In Highly Dynamic Situations , Signal's Doa May Be Changing Too Rapidly To Be Of Practical Use .

Consequently , Many Ew Systems Must Rely On Other Parameters , Such As Frequency Or Pulse Width , To Sort The Received Signals . Therefore , The Problem Of Making Decisions Based On Inexact Or Ambiguous Evidence Will Always Be Present To Some Degree .

Intercepting and then isolating the signal (s) of interest is (are) not the end goal of a large array of EW receiving system . In many cases , the intercepted signal must also be ascribed to a specific radar or class of radar in the environment . For example , ECM systems must determine the identity of a victim radar or threat before the appropriate jamming technique can be selected . The task of determining the identity of an intercepted signal is laden with uncertainty , since the evidence (data cluster) itself

contains uncertainty , and since each stage in the identification process introduces additional uncertainties . Nevertheless , an accurate identification must be made ; in some cases , an error can be fatal.

The final two blocks support the task of identifying and classifying the intercepted signals . The fourth block , the pattern extractor and tracker (PET) , uses the stored information from the deinterleaver to compute any patterns . (e.g., the pulse repetition interval (PRI) pattern) that may be contained in each data cluster (emitter) by using the appropriate data item from the PDWs stored in a cluster . The final and fifth block is the classifier , which describes each data cluster in the PET to a particular emitter .

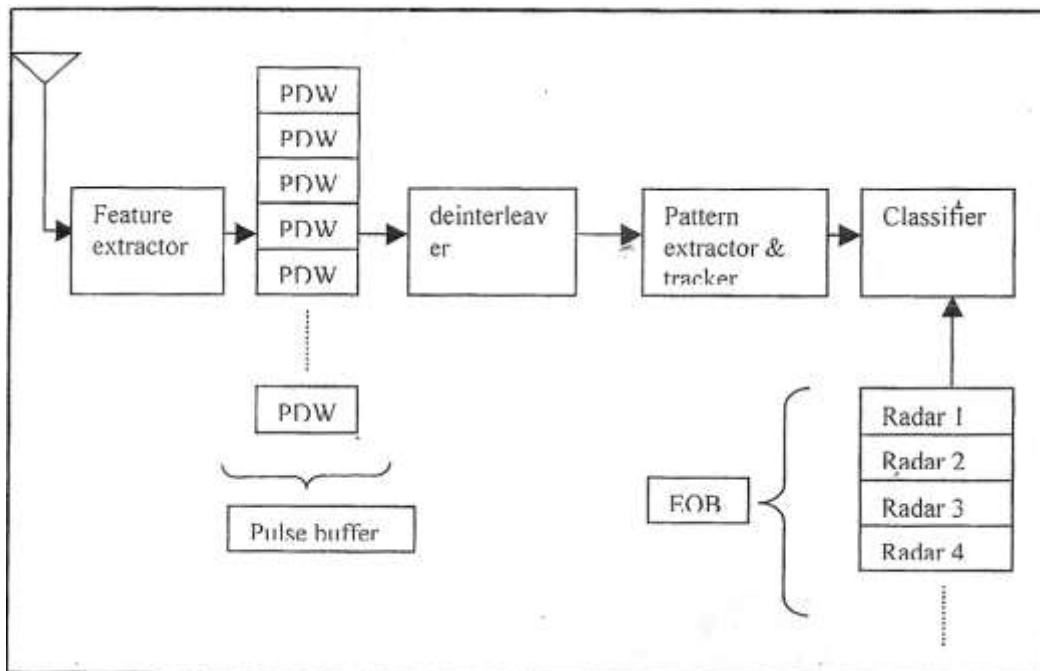

Fig. (4) : General block diagram of an EW receiving system

The identity of a particular signal is usually inferred by correlating the observed characteristics of that signal with those that are stored in the electronic order of battle (EOB) , which is a list that contains the identity and signal characteristics of all known radars or those likely to be encountered [Vac93] .

Major applications of EW receivers serve three purposes in EW system : they warn of enemy radar (radar warning receiver (RWR) , they support electronic jammers (electronic countermeasures (ECM) receiver) , and they aid reconnaissance (electronic intelligence (ELINT) receiver). The requirements for each of these functions are different , and so in most situations they are supported by different receives [Sch86].

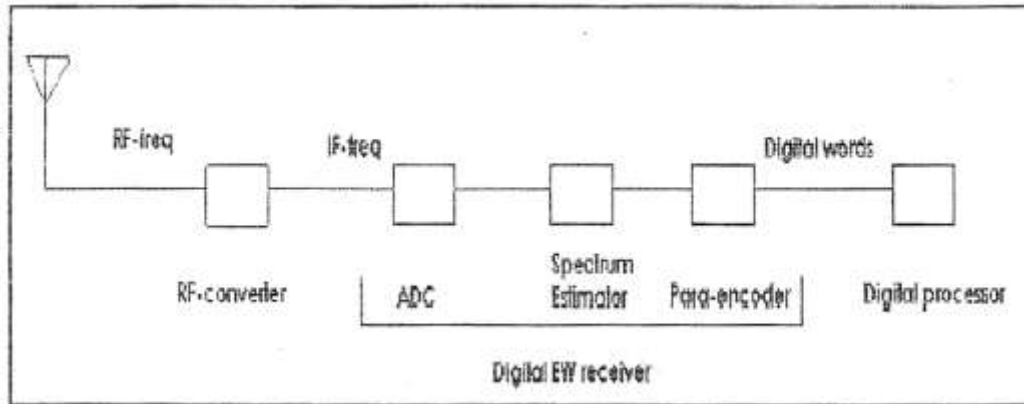

Fig. (5): Functional block scheme of digital EW receive.

RADAR SIGNALS : CW PULSE ,RF PULSE TRAIN AND CHIRPED TYPE SIGNALS

Most radars are designed to transmit a continuous train of RF pulses in order to perform target detection . These RF pulses have the same power , and share a common antenna for transmitting and receiving signals . For Continuous –Wave (CW) radars , the pulse is transmitted continuously , often through a separate transmitting and receiving antenna . Both of these radar designing operate mainly at a single frequency . For a high- resolution modern radar , see eq. (1) , it requires a wide radar bandwidth to increase the information about the location and the identity of target .

$$\text{Radar resolution } (\Delta r) = \frac{\text{Propagation velocity}}{2 \times \text{bandwidth}}$$

Pulsed radar signals ,are predominantly pulsed with widths varying between 0. micros and tens of microseconds . so they are transmitted as periodic pulse trains.

A chirped pulse is a RF pulse consisting of a sine wave that is phase modulated in such a way that linear frequency modulation results across the pulse duration . By statistical definition , a linear chirped sinusoidal signal is a non – stationary signal and is described as :

$$S(n) = \sqrt{Px} \exp j(2\pi fn + \psi n^2 / 2. \Phi) \quad (2) \text{ [Hau00]}$$

Where Ψ is the chirp rate of the signal f is the center frequency, n is the time period and Φ is the constant phase of the signal . The signal amplitude $\sqrt{p} x$ is constant but the signal is non-stationary due to the chirping of the frequency that sweeps linearly with time . The input signal $x(n)$ is given by :

$$x(n) = s(n) + \eta(n) \quad (3)$$

[Hau00].

Where $\eta(n)$ is a zero mean white noise (Gaussian) signal with noise power of P_{π} . Different radar signal properties are graphically illustrated in Fig.(6) [Bro79.Tin01].

PARAMETERS TO DETECT

A radar receiving system is generally used to extract the features of each input pulse , including RF, amplitude (Amp), pulse width (Pw). Angle of arrival (AOA) , time of arrival (TOA) , and modulation of pulse (MOP). Other parameters measured are pulse repetition interval (PRI) and burst repetition interval (BRI) .PRI indicates how often pulses arrive and BRI indicates how often groups of pulses arrive . For detailed discussion about the quantities that an EW receivers receive, one should refer to chapter three into [Sch86].

According to these features , the deinterleaver wants to cluster pulses which are emitted from distinct emitters into distinct groups . The ability of a radar system to determine and resolve these important target parameters depends on the characteristics of the transmitted radar signal.

Fig. (7) illustrates (a) CW pulse train signal with its time – frequency representation (b) CW chirped train signal with it time – frequency representation [Bro79].

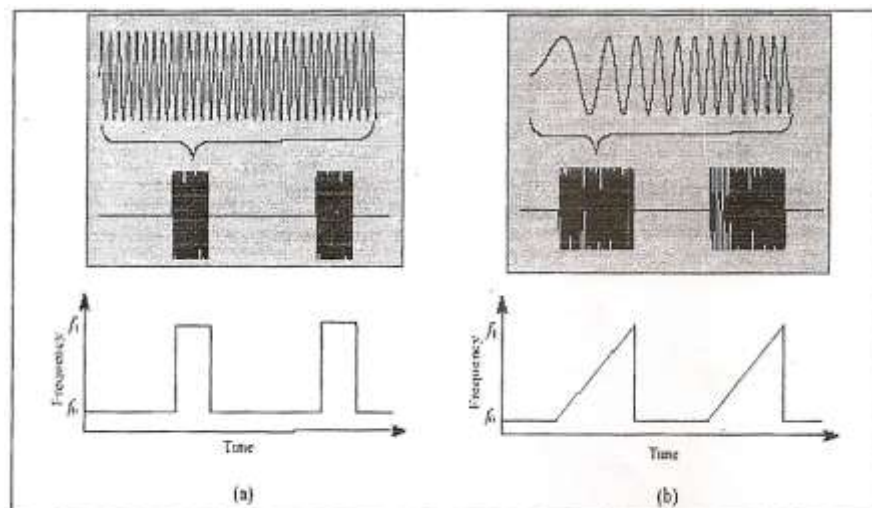
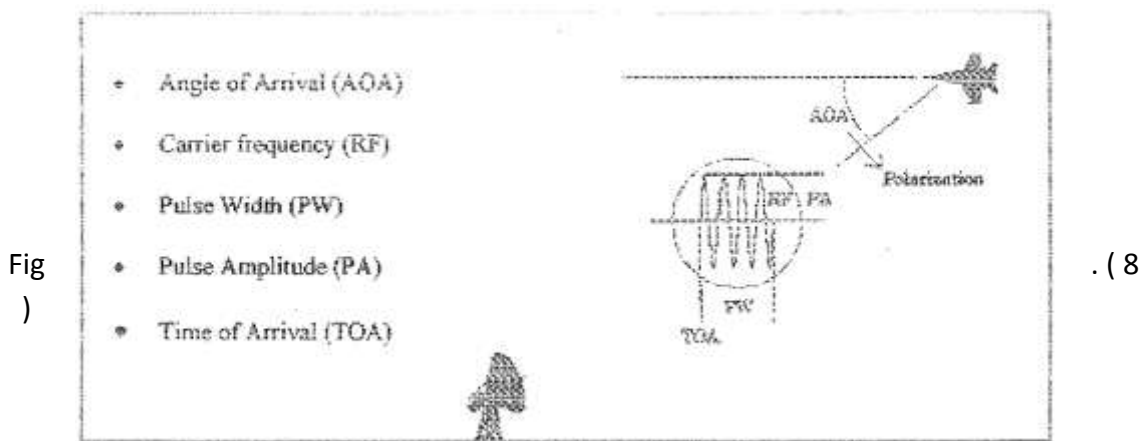

Fig. (7) : Pulse train signal with its time frequency

The train of interleaved pulses is processed in the ESM receiver to identify for each pulse the center frequency ,amplitude , PW ,TOA and bearing (or AOA), see fig. (8) The information is then input to a pulse sort processor , which deinterleaves it into the PRI appropriate to each emitter .

Further comparison against a store of known radar types permits the generation of an emitter list, classified with threat significance . Depending on the detected radar signal the pilot of an airplane gets information of the threat he is exposed to :



Parameters measured by receiver .

The receiver subsystem detects the radar pulses and measure the individual parameter , (the digital words a receiver generates and passes to a digital processor). The availability , resolution and accuracy of these measurements must all be taken into account when designing the deinterleaveing system . Obviously , the better the resolution and accuracy of any parameter measurement , the more efficiently the preprocessor can carry out its task . However , there are limitation on the measurement process from outside the ESM system (e.g. noise , jamming , and multipath) , inside the system (e.g. timing requirement)and from cost- effectiveness considerations.

SIMULATION RESULTS

In the following section different types of the radar signals will be evaluated by the radar-parameter- generation GUI package , from the applied signal flowgraph shown in Fig. (9) the signal shown in Fig. (10), some other samples of generated signals from there applied simulink shown in Fig.(11) , are shown in Fig.(12)and (13).

As a short summary ,the following individual units are used in Fig.(9) : they are further divided into different modules and sub modules in order to manipulate different types of input data.

The Input Unit.

The Digital Signal Processing Unit.

The EA Strategy Unit.

The Human Computer Interface Unit.

The Output Unit.

The Control and Management Unit and

The Power Calculation and Evaluation Unit.

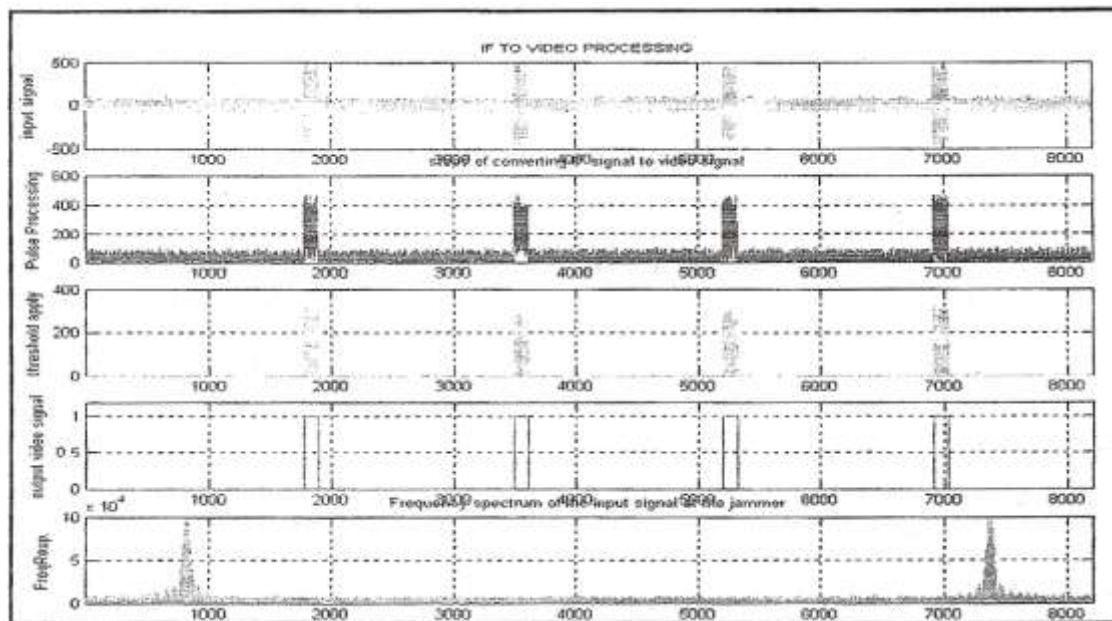

(10) Simulated sample of Radar signal.

Matlab-Simulink ,the processing and analyzing phases applied onto the received IF signals .It has the function of reading out the data samples of the digitized IF signal of constant , chirp , or nonlinear frequency modulation , converting the digitized IF into video signal measuring processed video pulse parameters and displaying time and frequency drawings of input and video signals. Fig. (11) shows the implemented model.



Fig.(11) :The simulink to generate a signal.

Fig. (11): Second sample of the radar signal

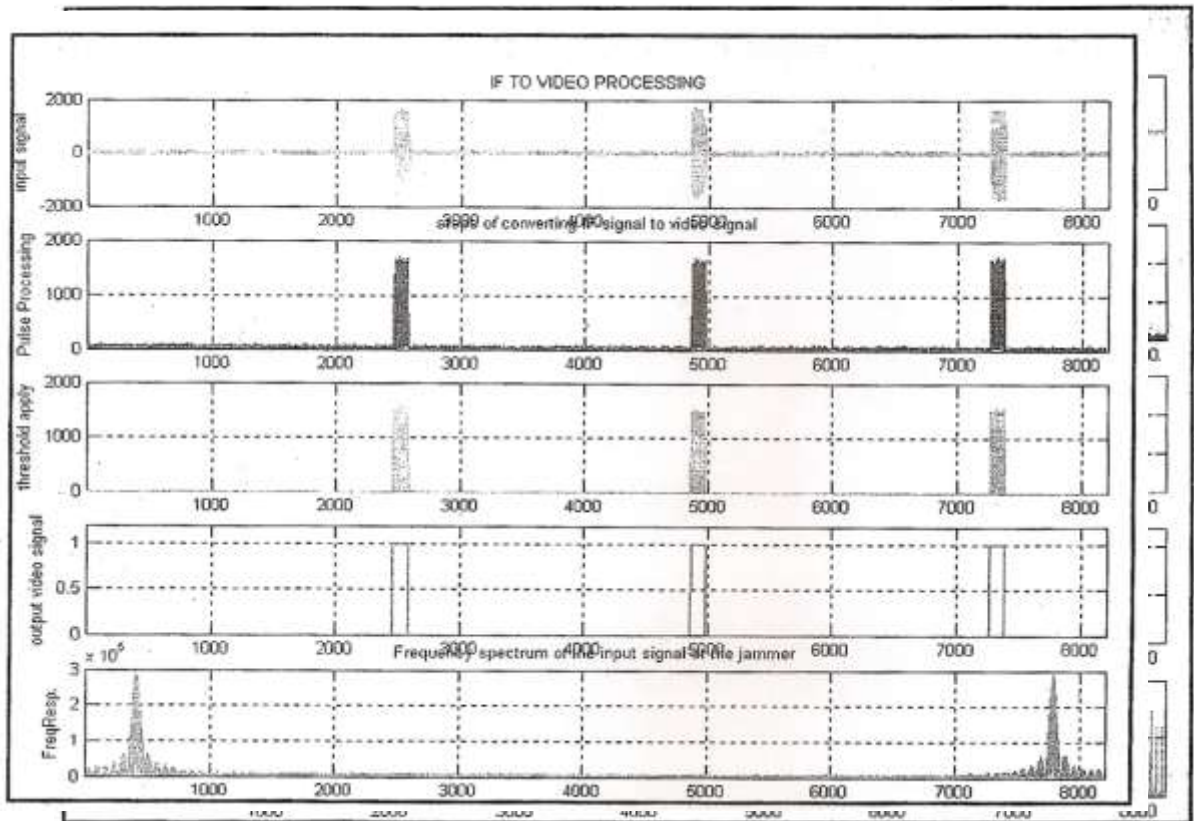

Fig.(12): Third sample of the radar signal

CONCLUSION



From the above results the generated electronic order of battle can be obtained hence, in order to identify any target the only requirement is to compare it with the available standard table.

REFERENCES

- Albaky B.M.,2003.”Interference Analysis and Generation in Radar System”, M.Sc. Thesis Electrical Eng. Dep. University of Baghdad.
- Fanden P., 2001, “Evaluation of Xilinx System Generator “ , M.Sc. Thesis, Linkping University Sweden.
- Ting L.K.,2001” Algorithm and FPGA Implementation of Adaptive LMS-Based Predictors for Radar Pulse Deinterleaving “ , Ph.D. Thesis Queen’s University Belfast.
- Hautaniemi S., 2000 “ Target Identification with Bayesian Networks”, M.Sc. Thesis Tampere University of Technology , Finland.
- Vaccaro D.D. , 1993, “Electronic Warfare Receiving System “ Artech House .
- Schleher D.C.,1986, “ Introduction to Electronic Warfare “, Artech House.
- Tsui J.B. , 1986 “ Microwave Receivers with Electronic Warfare Application “ John Wiley and Sons.
- Brookner E. “Radar Technology “ Artech House.