



EXPERIMENTAL INVESTIGATION OF REINFORCED CONCRETE FLEXURAL BEAMS STRENGTHENED OR REPAIRED WITH CFRP

Prof. Dr. Husain M. Husain*

Assist. Prof. Dr. Nazar K. Al-Oukaili**

DAWLAT D. ALI

* Building and Construction Department/ University of Technology

** College of Engineering/University of Baghdad

ABSTRACT

Fiber reinforced polymers are typically comprised of high strength fibers (e.g. carbon and glass) impregnated with an epoxy (often termed the matrix). Experimental investigations of the behavior of reinforced concrete beams, strengthened or repaired by CFRP for flexural case have been presented in this paper. The experimental program consisted of 14 test beams. The study took into account strengthened and repaired cases in using CFRP; therefore, similar beams were used once for strengthening and once for repairing to make a comparison between them. All beams had been tested in a simply supported span and subjected to two-point loading while the main variable is the quantity, distribution and location of CFRP. The beams included additional anchorage at the ends of the main CFRP sheet reinforcement to prevent end separation of CFRP sheet. The results of experiments show that the use of CFRP as external strengthening has significant enhancement on ultimate load, crack pattern and deflection. It is observed that the use of external CFRP in strengthening or repairing beams could enhance the ultimate load capacity up to 160% over the capacity of the identical reference (untreated) beam.

KEYWORDS: reinforced concrete beam, strengthening of concrete structures, repairing of R.C. structures, CFRP, Epoxy.

التحري العملي لعتبات الانثناء الخرسانية المسلحة المقواة أو المعاد تصلحها بالCFRP

الخلاصة:

الياف التقوية بالبولىمر تتألف بصورة مثالية من الياف عالية المقاومة (على سبيل المثال الكربون أو الزجاج) منغمسة بالايوكسي. التحريات العملية لسلوك العتبة الخرسانية المسلحة المقواة أو المعاد تصلحها بهذه الالياف لحالة انثناء العتبة تم تقديمها في هذا البحث. البرنامج العملي تألف من 14 عتبة فحص (عتبات انثناء) لدراسة اخذت بنظر الاعتبار حالي التقوية واعادة التصليح لذلك صنعت عتبات متشابهه ستستعمل واحدة منها للتقوية واخرى لاعادة التصليح لعمل مقارنة بينهما. كل العتبات تم فحصها بفضاء بسيط الاسناد ومتعرضة الى نقطتي تحميل بينما المتغيرات الرئيسية كانت كمية توزيع وموقع شرائح الالياف. مجموعة عتبات الانثناء تضمنت تثبيت اضافي في نهايات صفيحة تقوية الCFRP الرئيسي لمنع الانفصال صفيحة CFRP. نتائج الفحوصات العملية بينت أن استعمال CFRP كتقوية خارجية له تأثير كبير على الحمل الاقصى، شكل التشقق والهطول. تم الاستنتاج بان استعمال الCFRP الخارجي في التقوية أو اعادة تصليح عتبات الانثناء يمكن ان تعزز سعة الحمل الاقصى الى 160% من سعة العتبة المصدرية المثالية.

الكلمات الدالة : عتبة خرسانية مسلحة، تقوية خرسانة مسلحة، إعادة تصليح المنشآت الكونكريتية، CFRP ، غراء

INTRODUCTION

The need to develop economic and efficient methods to upgrade, repair, or strengthen existing reinforced concrete structures, Fiber Reinforced Polymer (FRP) plates or sheets or laminates have been found to be successful for flexural and shear strengthening and for ductility enhancement of concrete structures.

Strengthening of reinforced concrete beams with (FRP) composite is becoming an attractive alternative in the construction industry. These laminates offer the advantages of composite materials, such as immunity to corrosion, and allowing a high strength to weight ratio [1].

Due to the usually high cost of new construction there is an increasing need for repair, strengthening, or retrofit of (RC) structures. The concrete repair manufacturing industry is responding by producing new and more advanced materials for concrete repair and retrofit. A new structure composite technology that uses FRP has recently emerged as a very practical tool for strengthening and/or retrofitting of concrete structures, because of FRP's excellent strength to weight ratios. Reduced FRP material costs, relatively unlimited material length, comparably simpler construction and immunity to corrosion are some advantages of FRP. There are many types of FRP such as Carbon Fiber Reinforced Polymer, Glass Fiber Reinforced Polymer and Aramid Fiber Reinforced Polymer.

Carbon Fiber Reinforced Polymer (CFRP) sheets are used for strengthening and rehabilitation of beams. The advantages of using CFRP include reduced installation time, corrosion resistance and ease of application [1, 2, 3]. Also, externally bonded CFRP can be used to repair and strengthen damaged prestressed concrete girder bridges [1].

The objective of the present study is to investigate, experimentally and analytically, the behavior of reinforced concrete beams externally strengthened or repaired simple beams with Carbon Fiber Reinforced Polymer sheets (CFRP) attached to their flexural or shear sides.

EXPERIMENTAL PROGRAM:

The experimental program included fourteen beams that were designed to fail in bending (flexural). Table 1 shows the properties of these beams (with their designations).

MATERIAL PROPERTIES OF TEST SPECIMENS:

Normal weight concrete was used to cast all concrete components in the test program. Mix design was based on several trial mixes in order to have the most suitable fractions of components, and it arrives at the following proportions by weight: 1 cement; 1.5 sand; 3.0 gravel, to give a 28-day cylinder compressive strength of 41 N/mm² approximately. The water/cement ratio was 0.4 giving a slump of 80mm-100mm (medium workable mix). The mix design was according to ACI 211.1-91 [4].

**Table 1** Concrete material properties of test beams (flexural failure)

Type of test Beam name	1 f'_c (N/mm ²)	2 f_{cu} (N/mm ²)	3 f_t (N/mm ²)	4 f_r (N/mm ²)	5 f_r (N/mm ²)	6 E_c (N/mm ²)
BB1, BB2	41.3	49.2	3.62	4.88	4.49	30204
BB3, BB4	42.9	51.8	4.16	5.31	4.58	30784
BB5, BB6	42.5	55.3	3.68	5.19	4.56	30640
BB7, BB8	40.8	49	3.47	4.79	4.47	30021
BB9, BB10	44.1	53.1	3.48	4.87	4.64	31211
BB11, BB12	42.8	51	4.12	4.76	4.57	30748
BB13, BB14	40.8	49	3.6	4.85	4.47	30021

Notes (type of test):

- Concrete compressive strength by cylinder of 150mm*300mm in dimensions (adopted in the calculations of this study).
- Concrete compressive strength by cube of 150mm*150mm*150mm in dimensions.
- Concrete splitting tensile strength by cylinder of 150mm*300mm in dimensions.
- Concrete modulus of rupture (flexural strength) by prism of 100mm*100mm*500mm and loaded at third points (adopted in the calculations of this study).
- Concrete modulus of rupture according to ACI 318 [5], $f_r = 0.7\sqrt{f'_c}$ (N/mm²).
- Concrete modulus of elasticity according to ACI 318 [5], $E_c = 4700\sqrt{f'_c}$ (N/mm²), (adopted in the calculations of this study).

REINFORCEMENT BARS

Tensile tests were conducted on several specimens, at least three specimens, prepared from steel reinforcing bars which were used in the tested beams. Static yield stress and ultimate strength are summarized in Table 2. All steel reinforcement, used in this study, is assumed to have a modulus of elasticity equals to 210000 N/mm². The tensile tests were performed using the testing machine available at the Building Material Laboratory in the College of Engineering, Al-Mustansiriya University. The load and elongation readings were obtained from a digital computer complementary with the testing machine.

Table 2 Specifications and test results of steel reinforcement bars.

Reinforcement bar diameter (mm)	Yield Stress f_y (N/mm ²)	Ultimate Strength f_u (N/mm ²)	Modulus of Elasticity E^* (N/mm ²)
6	348	420	210000
8	355	422	210000
10	580	680	210000
12	596	685	210000
16	598	688	210000

* Assumed value.

CFRP

The uniaxial behavior of Carbon Fiber Reinforced Polymer (CFRP) sheets used in this study was assumed to be linear up to failure. Properties for the Carbon Fiber Reinforced Polymer and Epoxy systems were not determined in the laboratory. However, the properties published by the manufacturer (FOSROC) Nitowrap FRC were used to define the material properties for the analytical studies. Values of the parameters of the carbon fiber reinforced polymer are summarized in Table 3 for the specifications of the CFRP used in the present study.

Table 3 Specifications of the CFRP used in the present study (Fosroc/Nitorap)

Properties	CFRP 300HS(FRC)
Weight (g/m ²)	300
Thickness (mm)	0.167
Tensile strength (N/mm ²)	3550
Modulus of Elasticity (N/mm ²)	235000

DETAILS OF TEST BEAMS

Details of the strengthened and repaired beams by CFRP sheets are given in Table 4. Figures 1 and 2 show the general details of loading and the cross section.

Table 4 Specification of tested beams (Flexural Group)

Beam's Symbol	CFRP Locations	Working Status	Form's type
BB1 BB2	No strengthening	No strengthening	Control
BB3 BB9	External Longitudinal CFRP bonded on bottom face of beam	Strengthening	A _B
BB4 BB10	External longitudinal CFRP bonded on bottom & side faces of beam	Strengthening	B _B
BB5	External longitudinal CFRP bonded on side	Strengthening	C _B



BB11	faces of beam		
BB6 BB12	External longitudinal CFRP bonded on bottom face of beam	Repairing	A _B
BB7 BB13	External longitudinal CFRP bonded on bottom & side faces of beam	Repairing	B _B
BB8 BB14	External longitudinal CFRP bonded on sides faces of beam	Repairing	C _B

The form (A_B) represents strengthening or repairing of the flexural beams (BB) by gluing a sheet of CFRP at the bottom face of the beam (maximum tension region). This sheet has a length of 2350mm, width of 120mm, and thickness of 0.167mm. One layer of paste was used by a suitable epoxy. Two anchorage supports had been placed at the ends of the main longitudinal CFRP sheets by using a suitable epoxy as shown in Figure 3.a and b that clarify the details of form (A_B). Figures 4.a and b show the details of beams B_B and Figures 5.a and b show the details of C_B.

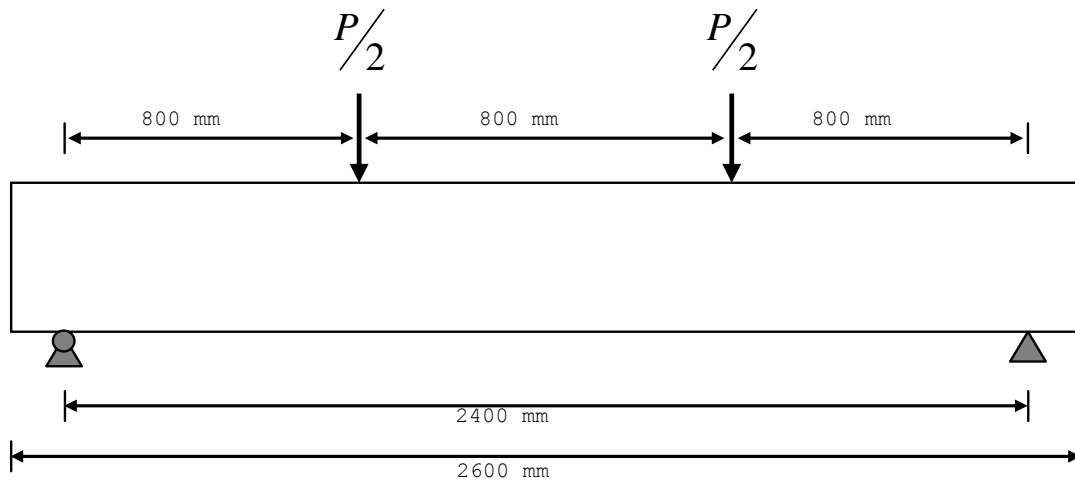

FIGURE 1 Dimensions and details of flexural beams



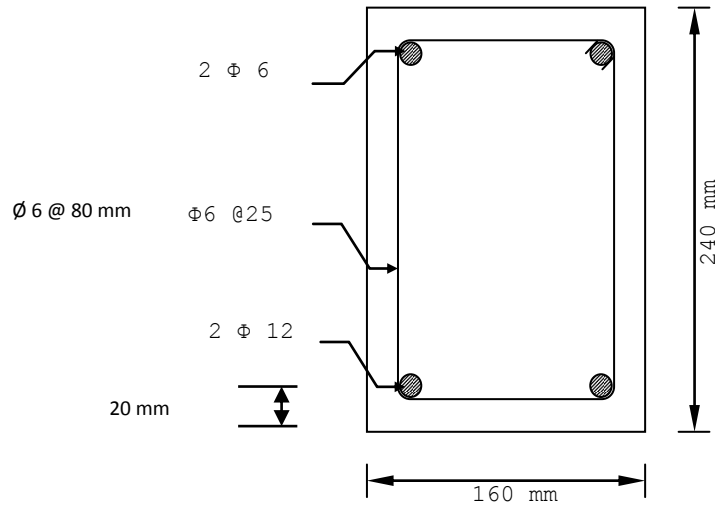

FIGURE 2 Cross section of flexural beam in shear span

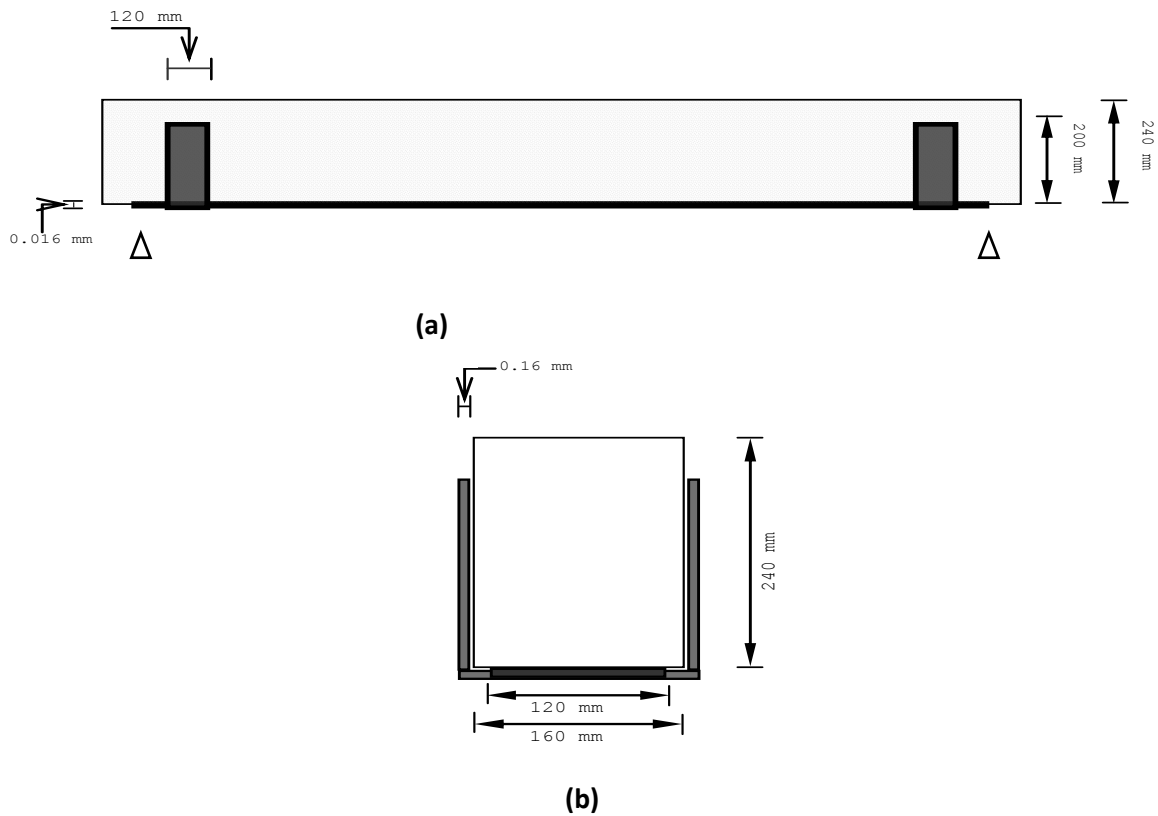

Figure 3 Specification and details of CFRP locations of beams A_B. (a) Front side view. (b) End side view

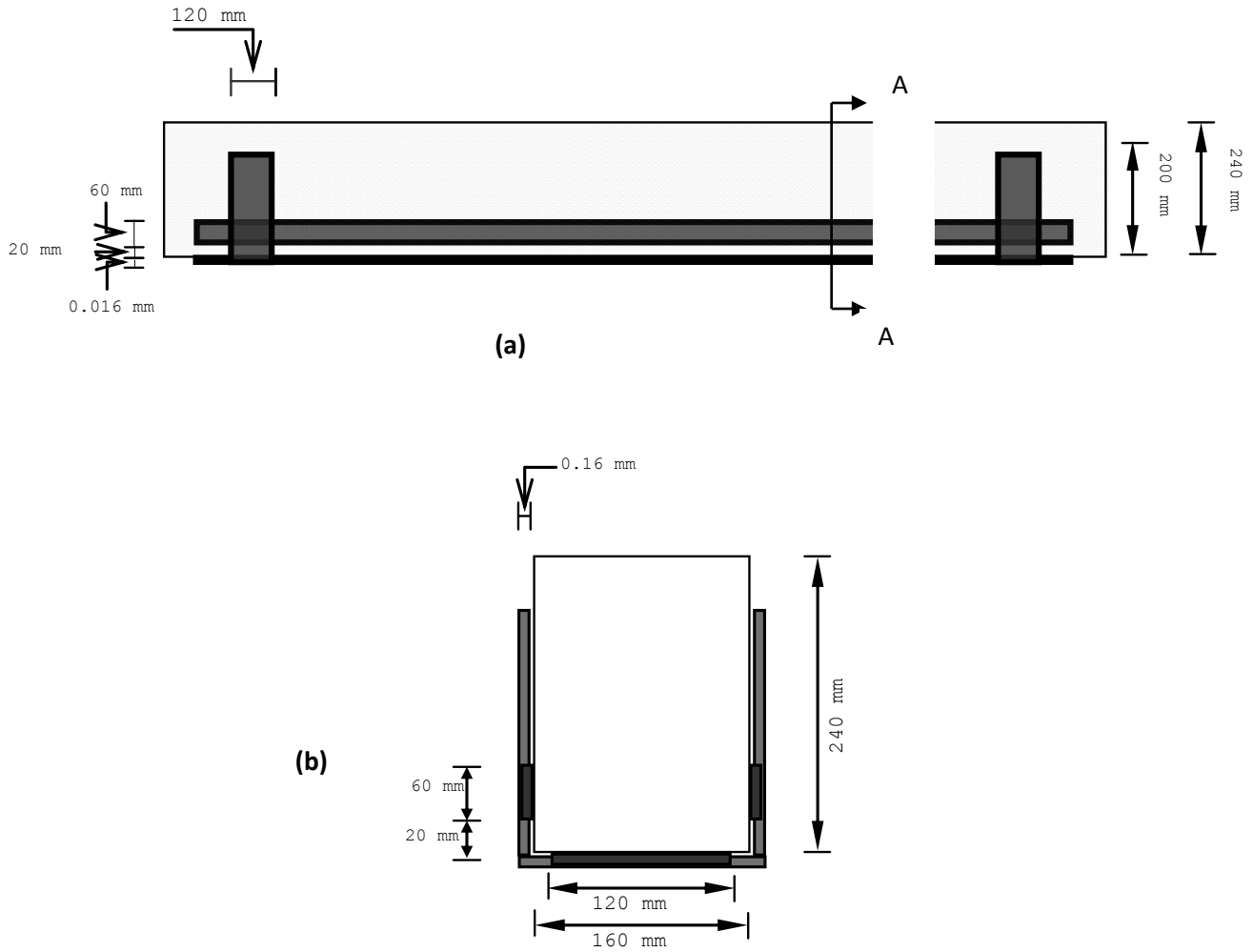

Figure 4 Specification and details of CFRP locations of beams B_B. (a) Front side view. (b) End side view (Section A-A)

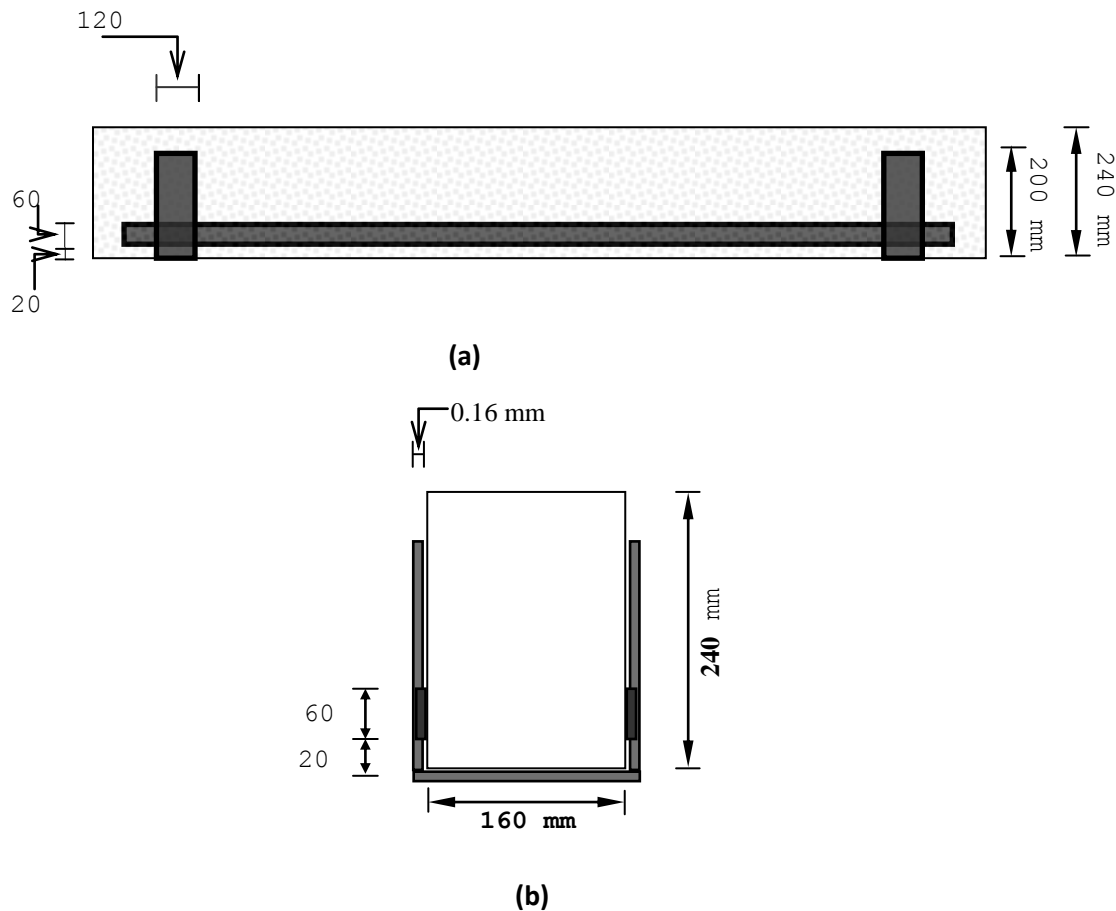

Figure 5 Specification and details of CFRP locations of beams C_B. (a) Front side view. (b) End side view

SUPPORT AND LOADING CONDITIONS

All beams were tested in a universal testing machine, model 8551 M. F. L. system, with maximum capacity of 3000kN. The adjustable supports were changed to suit the span of the test beams. The test beams were simply supported over a span of 2600mm and 2000mm (for flexural and shear groups respectively) and loaded with two-point loads (knife edge load, K.E.L.) applied and distributed across the entire width of the beams by using a solid rod. The beams were tested under static loads, loaded in successive increments, up to failure. For each increment, the load was kept constant until the required readings were recorded [6].

INSTRUMENTATION AND TEST PROCEDURE

During the test, the applied load and the corresponding deflections, at mid-span and under load (third-span of beam), were measured from the universal testing machine and the dial gauges (reading to 0.01mm); then, the outputs from each test beam were collected and used in plotting the load-deflection curves. Longitudinal strains, over the depth of the concrete layer at mid-span, were measured using 100mm demec gauge and the extensometer.

FLEXURAL GROUP

GENERAL BEHAVIOR

All beams were designed so that failure would occur in flexure. All the details were according to ACI building code requirements. The steel reinforcement and the concrete strength were selected to satisfy this demand. The general behavior of the tested beams can be summarized as below,

For the control beams, at early stages of loading, the deformations were initially within the elastic ranges, then the applied load was increased until the first crack occurred which was observed by a magnifying glass in the maximum moment region between the two-point loads. As the load was increased further, several flexural cracks initiated in the tension face at intervals along the span.

When the load was increased further, one mode of failure appeared which can be classified as flexural failure in tension by yielding of the main steel reinforcement.

The strengthened beams also showed similar behavior, but when the load level attained the value at which the steel is yielding, the CFRP contributed mainly in resisting the loads and increased the stiffness of the concrete beams up to failure. The failure was usually recorded due to sudden cut (rupture) of main longitudinal CFRP sheet at mid-span (maximum moment region). In case of repaired beams, the failure was similar to that observed in strengthened beams [6].

CONCRETE CRACKING

In the present study, the cracks initiated from the bottom concrete surface at the maximum moment region and moved upwards but did not reach the top fiber compression zone. Figures 6 and 7 show photographs for crack patterns for the control beams (BB1) and (BB2).



Figure 6 Crack pattern for beam BB1- control beam



Figure 7 Crack pattern for beam BB2- control beam

Figures 8 and 9 show the crack pattern for a beam strengthened with CFRP located at the bottom face of the beam. No major shear crack was noticed. Failure occurred by yielding of reinforcement and followed by CFRP rupture.



(a)



(b)

Figure 8 Crack pattern for beam BB3- strengthened beam (bottom face). **(a)** Cracks on overall beam. **(b)** Magnified picture for cracks at mid-span.

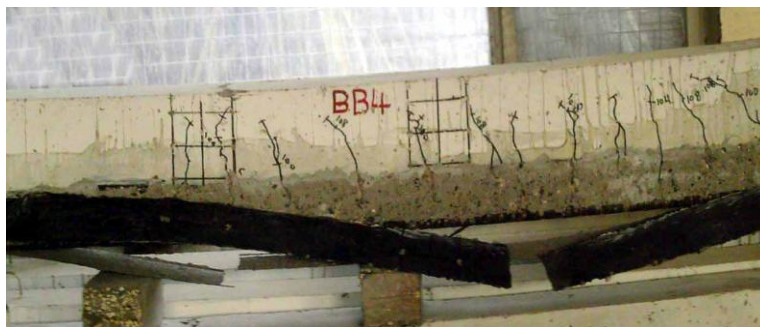

Figure 9 Crack pattern for beam BB9- strengthened beam (bottom face)

Figures 10 and 11 show the crack pattern for a beam strengthened with CFRP located at the bottom and side faces of the beam. The crack initially developed at bottom (tension zone). It is seen that the number of cracks has been reduced significantly due to presence of side face CFRP sheets. The beam failed before the cracks reach the top fiber. Failure occurred by yielding of reinforcement and followed by CFRP failure at the maximum moment zone (cut of the bottom CFRP and followed in the side CFRP sheets).



(a)



(b)

Figure 10 Crack pattern for beam BB4- strengthened beam (at bottom and side face by CFRP sheets). **(a)** Cracks on overall beam. **(b)** Magnified picture for cracks at mid-span.



Figure 11 Crack pattern for beam BB10- strengthened beam (at bottom and side face by CFRP sheets)

Figures 12 and 13 show the crack pattern for a beam strengthened with CFRP located at the sides of the beam only. Also, the cracks started in the (tension zone) and moved towards compression zone while the number of cracks was reduced due to presence of side face CFRP sheets. The beam failed before the cracks reach to the top fiber. Failure developed by yielding of reinforcement and followed by CFRP failure.



(a)



(b)

Figure 12 Crack pattern for beam BB5- strengthened beam (at sides of beam). (a) Cracks on overall beam. (b) Magnified picture for cracks at mid-span.



Figure 13 Crack pattern for beam BB11- strengthened beam (at sides of beam)

Figure 14 shows the crack pattern for the beam at 50% of failure loading and then repaired and loaded up to failure. The crack started at the bottom face (tension zone) and exceeded the middle of the beam. The crack width did not exceed 2mm.

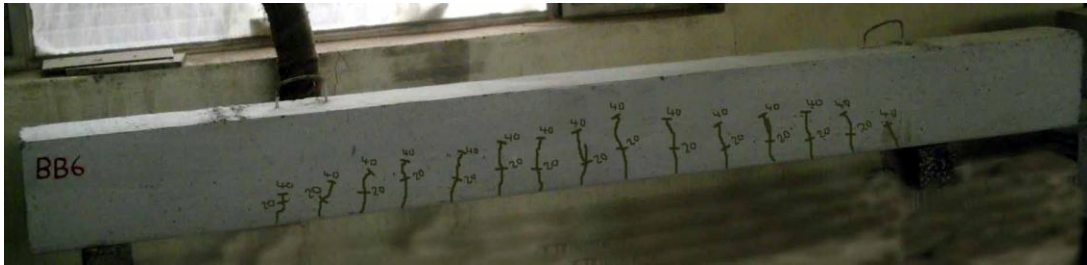

Figure 14 Crack pattern for beam BB6- (holding 50% of failure loading) before repairing.

Figures 16 to 20 show the crack pattern for the repaired cracked beams holding 50% of failure load, and then repaired and loaded up to failure. The failure mode and crack pattern are the same as in strengthened beams except that the load at failure in the repaired beams was less than the load at failure of the strengthened beams.



Figure 15 Crack pattern for beam BB6- (beam repaired by CFRP in bottom face)

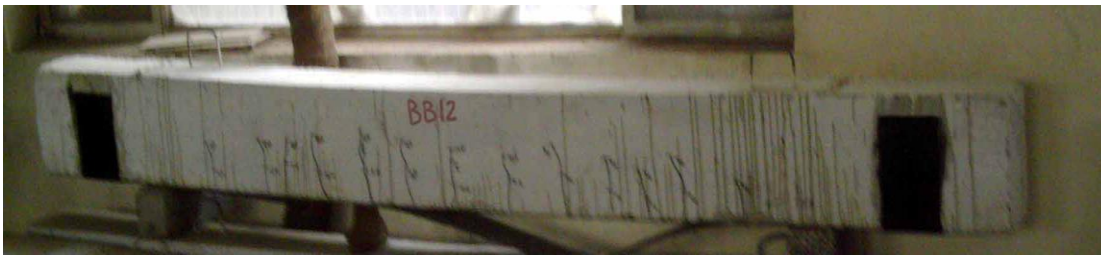

Figure 16 Crack pattern for beam BB12- (beam repaired by CFRP in bottom face)



Figure 17 Crack pattern for beam BB7- (beam repaired by CFRP in bottom and sides)



Figure 18 Crack pattern for beam BB13- (beam repaired by CFRP in bottom and sides)



Figure 19 Crack pattern for beam BB8- (beam repaired by CFRP in side faces)



Figure 20 Crack pattern for beam BB14- (beam repaired by CFRP in side faces)

LOAD-DEFLECTION CURVES

Load versus central deflection curves for the tested beams that had been constructed and tested to fail in flexure are shown in Figures 21 and 22. Figure 21 shows the load-deflection curves for the control and strengthened beams. Figure 22 show the load deflection curves for the control and repaired beams. The enhancement in stiffness and ultimate load by CFRP sheets is clear in these figures.

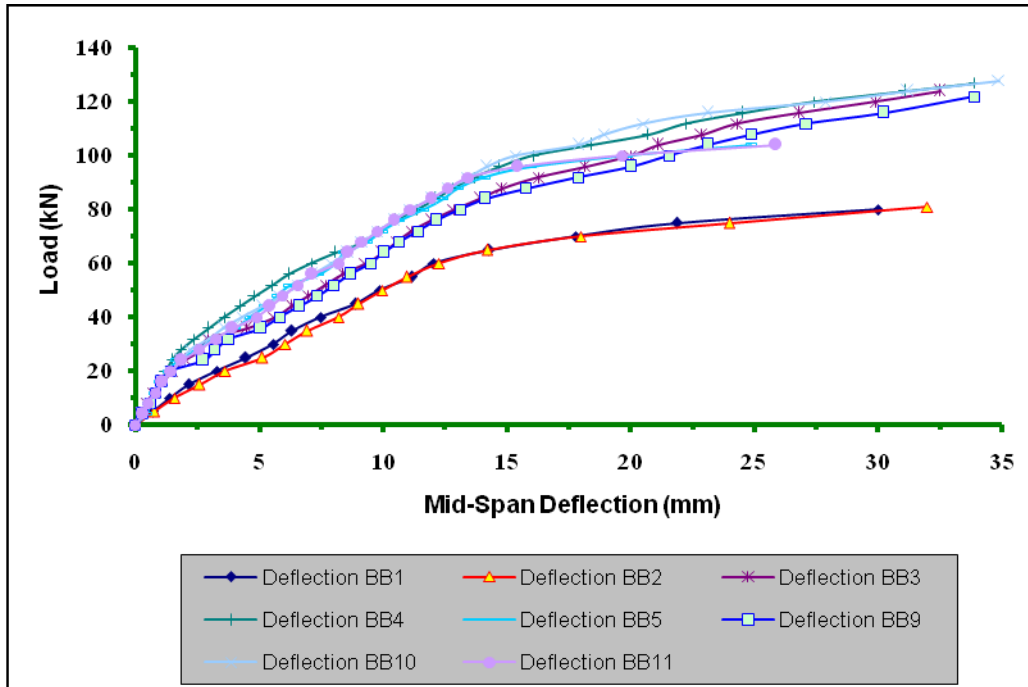

Figure 21 Load-deflection comparisons between strengthened and control beams

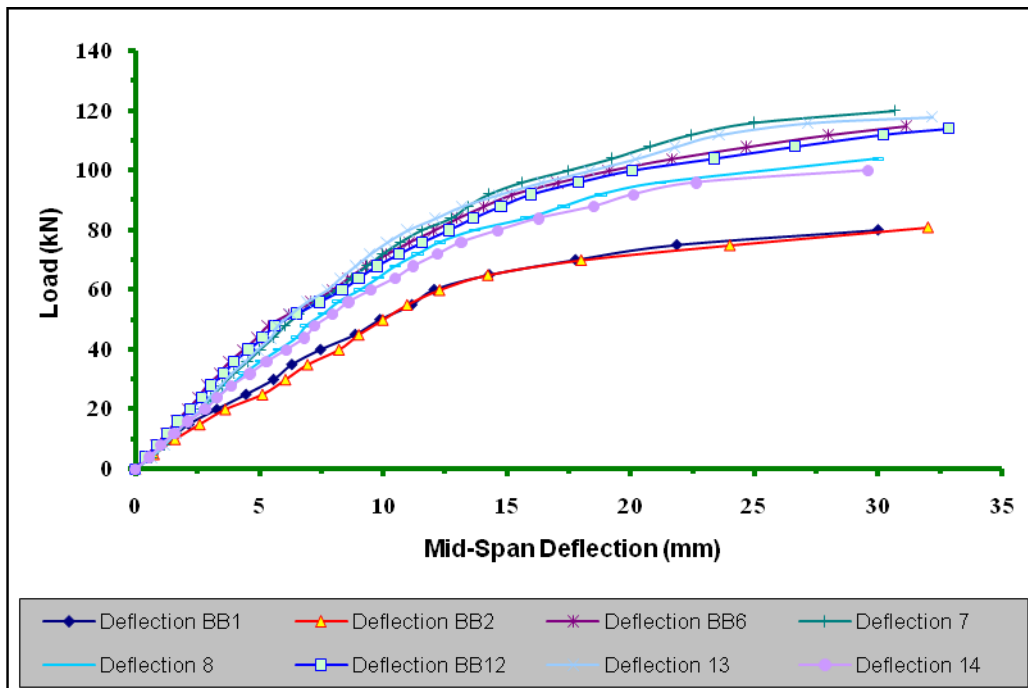

Figure 22 Load-Deflection Comparison between repaired and control beams

Conclusions

From test results and observations, the following major conclusions can be drawn:

- In all cases in the present work (flexural group), the failure in strengthened beams is caused by steel yielding followed by CFRP rupture.
- The presence of external CFRP bonded to concrete beams increases the ultimate load at failure to a significant value. The maximum increase in the ultimate strength of externally strengthened beams by CFRP depends on the amount of the area and configuration of the external CFRP sheet added.
- The use of external CFRP sheet connected to the tension sides of beams could enhance the ultimate load capacity by (160%) in flexure over the capacity of the identical unstrengthened control beam.
- Same behavior for strengthened and repaired beams is noticed except that the ultimate load in repaired beams reaches (95 % to 97 %) of ultimate load of strengthened beams.

REFERENCES:

- Klaiber, F.W., Wipf, J.J. and Kempers, B.J., "**Repair of Damaged Prestressed Concrete Bridges using CFRP**", Proceedings of the 2003 Mid Transportation Research Symposium, Ames, Iowa, August 2003 by Iowa State University, www.ctre.iastate.edu.
- Sergio, F. B., Regan M. B., Sharon L. Wood, and Michael E. K., "**Use of Carbon Fiber Reinforced Polymer Composites to Increase the Flexural Capacity of Reinforced Concrete Beams**", Research Project 0-1776 by the Center for Transportation Research Bureau of Engineering Research, the University of Texas at Austin, U.S.A., April 2001.
- Khan, A. R., "**Repair and Strengthening of Reinforced Concrete Structures using CFRP Plates**", FEST Hamadard University, India, 2002.
- ACI Committee 211, "**Standard Practice for Selecting Proportions for Normal, Heavyweight, and Mass Concrete (ACI 211.1-91 Code)**", Reapproved 1997, American Concrete Institute, Michigan, U.S.A.
- ACI Committee 318, "**Building Code Requirements for Structural Concrete (318M-02) and Commentary (318RM-02)**", American Concrete Institute, Michigan, USA, 2002.
- Ali, D. D., "**Experimental and Theoretical Investigation of the Behavior of Reinforced Concrete Beams Strengthened by Fiber Reinforced Polymer**", Ph.D. Thesis, Baghdad University, 2007.