

Electrical, Electronics and communications, and Computer Engineering

Implementation of Power System Stabilizer Based on Conventional and Fuzzy Logic Controllers

Hanan Mikhael Habbi

Lecturer

Electrical Engineering Department
Engineering College, University of Baghdad
hhabbi@gmail.com

Ahmed Alhamadani

M.Sc. Student

Electrical Engineering Department,
Engineering College, University of Baghdad
Ahmedalhamadani61@yahoo.com

ABSTRACT

To damp the low-frequency oscillations which occurred due to the disturbances in the electrical power system, the generators are equipped with Power System Stabilizer (PSS) that provide supplementary feedback stabilizing signals. The low-frequency oscillations in power system are classified as local mode oscillations, intra-area mode oscillation, and interarea mode oscillations. A suitable PSS model was selected considering the low frequencies oscillation in the inter-area mode based on conventional PSS and Fuzzy Logic Controller. Two types of (FIS) Mamdani and suggeno were considered in this paper. The software of the methods was executed using MATLAB R2015a package.

Key Words: Power system stabilizer, fuzzy logic, conventional PSS, AVR

تطبيق منظومة مثبت القدرة اعتمادا على النظام التقليدي والمسيطرات المنطقية المضببة

حنان ميخائيل حبي

مدرس دكتور

قسم الهندسة الكهربائية. كلية الهندسة. جامعة بغداد

احمد عبد الكاظم الحمداني

طالب ماجستير

قسم الهندسة الكهربائية. كلية الهندسة. جامعة بغداد

الخلاصة

من اجل اخمد تذبذبات الترددات المنخفضة التي تحدث في الشبكة الكهربائية نتيجة اضطرابات معينة. تم تزويد محطات التوليد بمنظومة مثبت القدرة وهذه المنظومة من شأنها تغذية اشارات استرجاعية مستقرة سائدة . ان تذبذب الترددات المنخفضة في نظام القدرة يمكن تصنيفه الى تذبذبات موقعية, تذبذبات المناطق المتداخلة, تذبذبات المناطق التداخلية. اختيار موديل منظومة مثبت القدرة مع الاخذ بنظر الاعتبار تذبذبات الترددات القليلة في المناطق التداخلية اعتمادا على النظام التقليدي والمسيطر المنطقي المضبب. وتم استخدام نوعان من نظام التداخل المضبب وهما مامداني وسوجينو. البرمجيات التي استخدمت بتنفيذ هذه الطرق هو برنامج ماتلاب 2015.

الكلمات الرئيسية: نظام مثبت القدرة , المنطق المضبب, نظام مثبت القدرة التقليدي, منظم الفولتية الاوتوماتيكي.



1. INTRODUCTION

The dynamicity is one of the most important characteristics of the power system. It is regularly affected by disturbances and that lead to a change in the voltage angle of the generator. When these disturbances cleared a new operating condition is reaches **Kundur, 1994**, it is very important the system doesn't become unstable or unbalance due to these disturbances, the disturbances are classified into three main classifications which are a local mode with frequency boundaries 0.7 to 2 Hz, inter-area mode with 0.1 to 0.8 frequency range. The eliminating of synchronous torque can be accomplished by high gain voltage regulator but it has a negative effect on the damping torque. In order equalize the unnecessary voltage regulators. The supplementary signals are drawn from speed deviation, accelerating power or excitation deviation. This is achieved by injecting stabilizing signal into the excitation summing point junction. Power system stabilizer (PSS) is the name of the device that can supply this supplementary control signals, **Anderson, 2013**.

The setting of the automatic voltage regulator (AVR) is one of the factors that affect the stability of the synchronous generator, **Machowski, et al., 2008**.

Extending stability boundaries is the main purpose of PSS through improvement of excitation to supply +ve damping torque and to power swing modes.

Fixed setting gain is the main disadvantage of the Conventional power system stabilizer (CPSS) because this setting is dealing with the unique operating condition and that lead to poor performance for different loading points of the synchronous generator.

2. SYSTEM MODELING

The Mathematical system modeling required for small signal analysis of Synchronous Machine, excitation system and lead-lag power system stabilizer is concisely studied . As well as, the strategies for the choice of PSS parameters are obtainable.

2.1 Synchronous Machine Model

The Synchronous Machine is vital for power system operation. The general system configuration of synchronous machine connected to the infinite bus through transmission network can be characterized as the mathematical models needed for small signal analysis of SYNCHRONOUS MACHINE; excitation system and the lead-lag power system stabilizer are briefly reviewed **Kamlesh, 2011**.

The guidelines for the selection of PSS parameters are also presented. The Thevenin's equivalent circuit illustrated in **Fig. 1**.

2.2 Classical System Model

The generator is denoted as the voltage E' behind X_d' as illustrated in **Fig. 2**. The magnitude of E' is assumed to remain constant at the pre-disturbance value. Let δ be the angle by which E' leads the infinite bus voltage E_B . The δ changes with rotor oscillation. The line current is stated as [1]

$$I_t = \frac{\dot{E} \angle 0^\circ - E_B \angle -\delta}{jX_T} = \frac{\dot{E} - (E_B \cos \delta - j \sin \delta)}{jX_T} \quad (1)$$

The Complex Power behind X_d' is given by:

$$S = P + jQ = \frac{E' E_B \sin \delta}{X_T} + j \frac{E'(E' - E_B \cos \delta)}{X_T} \quad (2)$$



With stator resistance ignored, the air-gap power (P_e) is equal to the terminal power (P). In per unit, the air-gap torque is equal to the air-gap power. Hence

$$T_e = P = \frac{E' E_B \sin \delta}{X_T} \quad (3)$$

Linearizing about an initial operating condition represented by $\delta = \delta_o$ yield

$$\Delta T_e = \frac{\partial T_e}{\partial \delta} \Delta \delta = \frac{E' E_B \cos \delta}{X_T} (\Delta \delta) \quad (4)$$

The equations of motion are:

$$p \Delta \omega_r = \frac{1}{2H} (T_m - T_e - K_D \Delta \omega_r) \quad (5)$$

$$p \delta = \omega_o \Delta \omega_r \quad (6)$$

Where $\Delta \omega_r$ is the per unit speed deviation, δ is rotor angle in electrical radians, ω_o is the base rotor electrical speed in radian per second, and p is differential operator d/dt with time t in seconds[2].

$$p \Delta \omega_r = \frac{1}{2H} (\Delta T_m - K_S \Delta \delta - K_D \Delta \omega_r) \quad (7)$$

where K_S is the synchronizing torque coefficient given by[3]

$$K_S = \left(\frac{E' E_B}{X_T} \right) \cos \delta_o \quad (8)$$

$$\frac{d}{dt} \begin{bmatrix} \Delta \omega_r \\ \Delta \delta \end{bmatrix} = \begin{bmatrix} -K_D & -K_S \\ 2H & 0 \end{bmatrix} \begin{bmatrix} \Delta \omega_r \\ \Delta \delta \end{bmatrix} + \begin{bmatrix} 1 \\ 2H \end{bmatrix} \Delta T_m \quad (9)$$

$\dot{\mathbf{x}} = \mathbf{Ax} + \mathbf{Bu}$. The basics of the state matrix \mathbf{A} are seen to be dependent on the constraints K_D , H , X_T , and the initial operating condition denoted by the values of E' and δ_o . The block diagram symbol exposed in **Fig.3** can be used to define the small-signal functioning.

So, the undamped natural frequency is

$$\omega_n = \sqrt{K_S \frac{\omega_o}{2H}} \text{ rad/s} \quad (10)$$

And the damping ratio is

$$\zeta = \frac{1}{2} \frac{K_D}{2H\omega_n} \quad (11)$$

$$= \frac{1}{2} \frac{K_D}{\sqrt{K_S 2H\omega_o}} \quad (12)$$



As the synchronizing torque coefficient K_S increases, the natural frequency increases, and the damping ratio decreases. An increase in damping torque coefficient K_D increases the damping ratio, whereas an increase in inertia constant decreases both ω_n and ω_o .

2.3 PSS Model

Controlling its excitation using auxiliary stabilizing signals is the main function of PSS by adding damping to oscillations of the generator rotor. A component of electrical torque in phase with rotor speed deviation must be provided by PSS in order to provide damping as illustrated in **Fig. 4**.

Since the damping torque component is produced by PSS. Speed deviation $\Delta\omega_r$ is the generator excitation signal. The transfer function of PSS, $GPSS(s)$, should have suitable phase compensation circuits to balance the phase lag between exciter input and electrical torque. The phase compensation block delivers the suitable phase lead features to compensate for the phase lag. The phase compensation may be a single first-order block as illustrated in **Fig.5** or having two or more first-order blocks or second order blocks with complex roots.

The signal washout block serves as high pass filter, with a time constant (T_w) high enough to allow signals associated with oscillations in ω_r to pass unchanged, which removes d.c. signals. Without it, steady changes in speed would modify the terminal voltage. It allows PSS to respond only to changes in speed. The stabilizer gain K_{STAB} determines the amount of damping introduced by PSS. Ideally, the gain should be set at a value corresponding to maximum damping; however, it is limited by other consideration. The PSS parameters should be such that the control system results in the following: -

- Maximize the damping of local plant mode as well as inter-area mode oscillations without compromising the stability of other modes .
- Enhance system transient stability .
- Not adversely affect system performance during major system upsets which cause large frequency excursions .
- Minimize the consequences of excitation system malfunction due to component failure .

3. CONVENTIONAL POWER SYSTEM STABILIZER (CPSS)

For the straightforwardness a CPSS is demonstrated by 2 stage (identical), lead/lag network which is denoted by a gain K_{STAB} and two-time constants T_1 and T_2 . This network is connected with a washout circuit of a time constant T_w as illustrated in **Fig.6**. In **Fig. 6**, the phase compensation block provides the appropriate phase lead characteristics to compensate for the phase lag between exciter input and generator electrical torque.

4. FUZZY LOGIC CONTROLLER

Fuzzy logic is derived from standard Boolean logic and implements soft linguistic variables on a nonstop range of truth values to be distinct between conventional binary i.e. [0, 1]. It can frequently be deemed a subset of the conventional set system, **Manish and, Ranjeeta, 2013, and Manish and Ranjeeta, 2012**. The fuzzy logic is capable to handle estimated information in a systematic way and therefore it is suited for controlling non-linear systems and for modeling complex systems where an inexact model exists or systems where ambiguity or vagueness is common. It is an advantage to use fuzzy logic in controller design due to the following reasons: -



- A Simpler and faster Methodology .
- It reduces the design development cycle .
- It simplifies design complexity .
- An alternative solution to non-linear control .
- Improves the control performance .
- Simple to implement .
- Reduces hardware cost .

4.1 Fuzzy sets

Fuzzy set, as the name implies, is a set without crisp limits. The transition from "belong to a set" to "not belong to a set" is gradual, and this soft transition is considered by MF. The fuzzy set philosophy is grounded on fuzzy logic, where a particular object has a degree of membership in a certain set that may be anywhere in the range of 0 to 1. also, the standard set theory is based on Boolean logic, where a particular object or variable is either a member of a given set (logic 1), or it is not (logic 0) .

4.2 Membership functions

There are several types of membership functions such as (triangular, Gaussian and Trapezoidal) in this paper the triangular membership function is chosen to represent the input signal (speed deviation and accelerating) and the output signal which is the stabilizing voltage.

4.3 Fuzzy Systems

The fuzzy inference system or fuzzy system is a popular computing framework based on the concept of fuzzy set theory, fuzzy if-then rules, and fuzzy reasoning. The fuzzy inference system basically consists of a formulation of the mapping from a given input set to an output set using FL as illustrated in **Fig.7**. The charting process provides the basis from which the inference or conclusion can be made. The basic structure of fuzzy inference system consists of three conceptual components: a rule base, which contains a selection of fuzzy rules; a database, which defines the membership functions used in the fuzzy rules; and a reasoning mechanism which performs the inference procedure upon the rules and given facts to derive a reasonable output or conclusion. The fuzzy logic controller comprises 4 principal components: fuzzification interface, knowledge base, decision making logic, and defuzzification interface.

- Fuzzification: In fuzzification, the values of input variables are measured i.e. it converts the input data into suitable linguistic values .
- Knowledgebase: The knowledge base consists of a database and linguistic control rule base. The database provides the necessary definitions, which are used to define the linguistic control rules and fuzzy data manipulation in an FLC. The rule base characterizes the control policy of domain experts by means of a set of linguistic control rules .
- Decision-making logic: The decision making logic has the capability of stimulating human decision making based on fuzzy concepts .
- Defuzzification: The defuzzification performs scale mapping, which converts the range of values of output variables into the corresponding universe of discourse. If the output from



the defuzzifier is a control action for a process, then the system is a non-fuzzy logic decision system. There are different techniques for defuzzification such as maximum method, height method, centroid method etc .

The basic inference process consists of the following five steps :

1. Step 1: Fuzzification of input variables
2. Step2: Application of fuzzy operator (AND, OR, NOT) in the IF (antecedent) part of the rule
3. Step3: Implication from the antecedent to the consequent THEN part of the rule
4. Step4: Aggregation of the consequents across the rules
5. Step5: Defuzzification.

4.4 Input/output Variables

The design starts with assigning the mapped variables inputs/output of the fuzzy logic controller (FLC). The first input variable to the FLC is the generator speed deviation and the second is acceleration. The output variable to the FLC is the voltage. After choosing proper variables as input and output of the fuzzy controller, it is required to decide on the linguistic variables. These variables transform the numerical values of the input of the fuzzy controller to fuzzy quantities. The number of linguistic variables describing the fuzzy subsets of a variable varies according to the application. Here seven linguistic variables for each of the input and output variables are used to describe them. **Table 1** shows the membership functions for fuzzy variables. The membership function maps the crisp values into fuzzy variables. The triangular membership functions are used to define the degree of membership. Here for each input variable, seven labels are defined namely, NB, NM, NS, ZE, PS, PM, and PB. Each subset is associated with a triangular membership function to form a set of seven membership functions for each fuzzy variable .

Triangular membership functions are used to define the degree of membership. Here for each input variable, seven labels are defined namely, NB, NM, NS, ZE, PS, PM, and PB. Each subset is associated with a triangular membership function to form a set of seven membership functions for each fuzzy variable, **Sirwan, et al., 2012, Slimane and Djilani, 2013.**

5. SIMULATION AND RESULTS

The presentation of SMIB system has been studied (1) no Excitation System. (2) Excitation System. (3) Conventional PSS (lead-lag) and (4) FLPSS. Schematic Models of SYNCHRONOUS MACHINE., Excitation System and CPSS are presented .

5.1. Performance with constant field voltage

The model used in the Simulink to study the response of the system with constant field voltage is illustrated in **Fig. 8**. In this illustration, the dynamic features are represented in terms of K constant. The values of K constant are calculated via parameters are: -
 $K_1 = 0.7635$, $K_2 = 0.8643$, $K_3 = 0.3230$, $K_4 = 1.4188$. Fig. 9 shows the system response for a 5% change in mechanical input with constant field only.



5.2 Performance with Excitation System only

The standard IEEE type ST1A excitation system model has been considered for the study and integrated it with the single machine infinite bus system. Correspondingly, the Simulink model is illustrated in **Fig. 10**. The excitation system parameters are taken as $K = 200$ and $TR = 0.02$. The values of 'K' constants calculated using above parameters: $K_1=0.7635$, $K_2=0.8643$, $K_3=0.3230$, $K_4=1.4188$, $K_5 = -0.1462$, $K_6=0.4166$.

The system behavior for a 5% variation in mechanical input with +ve K_5 is illustrated in **Fig. 11**.

Whereas, the system reaction for a 5% variation in mechanical input with -ve K_5 is illustrated in **Fig. 12**.

5.3 Performance with Conventional PSS lead-lag

The simulink model of lead-lag power system stabilizer is illustrated in **Fig. 13**. The deviation of angular position and angular speed with time for 0.05 pu increase in torque for -ve and +ve value of K_5 are illustrated in **Fig.14** and **Fig. 15** respectively. The system is coming out to be stable in both the cases; however, the transients are more with negative K_5 whereas the higher angular position is attained with +ve K_5 . The external network impedance $R_E + jX_E$ and operating condition can determine the value of K_5 positive or negative. The value of K_5 has a major influence of the AVR on the damping of system oscillations. With +ve K_5 , the effect of the AVR is to present a -ve synchronizing torque and a +ve damping torque component. The constant K_5 is +ve for low values of external system reactance and low generator outputs. With K_5 -ve, the AVR action introduces a +ve synchronizing torque component and a -ve damping torque component. This effect is more pronounced as the exciter reaction rises .

5.4 Performance with Fuzzy Logic Based PSS

The Model used in Simulink/Matlab to analyze the effect of fuzzy logic controller in damping small signal oscillations when implemented on single machine infinite bus system is illustrated below in **Fig.16** . As illustrated in **Fig. 16**, the fuzzy logic controller block consists of fuzzy logic Block and scaling factors . The input scaling factors are two, one for each input and one scaling factor for output which determines the extent to which controlling effect is produced by the controller. The performance of fuzzy logic controller is studied for the scaling factors having the values as $K_{in1}=1.6$, $K_{in2}=29.56$, $K_{out}=1.06$.

5.4.1 Mamdani Fuzzy Inference System (MFIS)

Fuzzy logic block is prepared using FIS file in Matlab (R2015a) and the basic structure of this FIS editor file as illustrated in **Fig.17**. This is executed using following FIS (Fuzzy Inference System) properties :

And Method: Min

Or Method: Max

Implication: Min

Aggregation: Max

Defuzzification: centroid



Table 2 shows the speed deviation and acceleration rule base for fuzzy logic controller. For the above FIS system, Mamdani type of rule-base model is used result of which gets the output in fuzzified form . Exact output is generated by the Normal System which uses a defuzzification procedure to change the inferred possibility distribution of an output variable to a representative Precise Value. In the above given Fuzzy Inference System, this work is done using centroid Defuzzification Principle Technique. In this system, minimum implication together with the maximum aggregation operator is used.

5.4.2 Sugeno Fuzzy Interface System (SFIS)

This section reviews the performance of Sugeno FIS(SFIS). It is comparable to the Mamdani FIS (MFIS) in several respects. The first two parts of the fuzzy interface process, are exactly identical. One of the significant differences between Mamdani FIS and sugeno FIS is that the SFIS output MFs are either constant or linear.

It can be illustrated from **Fig.18** that the torque variation response has a quite oscillation (about 2% with respect to steady state value) and a slow response for the angular position (it takes about 3 sec). for a -ve value of K5 it can be obtained that the angular position has 0.05 p.u steady state and with an overshoot of 2% for torque variation response. However, the angular position reaches its rated within 1 sec.

A smooth increasing in both angular position and torque variation responses that reaching steady state within 1 sec for +ve K5 sugeno FLPSS as illustrated in **Fig. 21**. An overshoot is produced in both the angular position (2%) and torque variation (1.65%) when K5 is -ve as illustrated in **Fig. 19**.

In the **Fig. 22**, a comparison between the angular speed in case of Mamdani memberships and sugeno membership and it is observed that the oscillation of angular speed response is high for sugeno membership. **Fig.23** shows a Comparison of angular position with CPSS and FLPSS when K5 is +ve while **Fig. 24** illustrates a comparison of angular position with CPSS and FLPSS when K5 is negative. **Figs. 25 and 26** show a comparison of angular speed with CPSS and FLPSS when +ve K5 and negative K5 respectively.

6. CONCLUSIONS

The effectiveness of PSS in damping low-frequency oscillation is studied. Speed deviation and acceleration are considered as an input signal to the fuzzy controller and the voltage as an output signal. FLPSS have excellent performance compare to CPSSS with respect to settling time and damping effect. Thus, it can be concluded that the presentation of FLPSS is better than conventional PSS. However, the selection of membership is the very important to effect on damping oscillation .

The simulation results are five percent change in mechanical torque. It can be observed that with fuzzy logic the rise time and the settling time of the system is reduced. The system becomes steady state faster with FLPSS rather than with CPSS for -ve K5 value. While with the +ve value of K5, the slow response (overdamped response) characteristic is resulted and the settling time remains largely unaffected. The step response characteristics for angular position for both lead-lag PSS and FLPSS are compared for -ve and +ve values of K5.



From relative plots it can be retrieved that oscillations in angular speed reduce much faster with fuzzy logic power system stabilizer than with CPSS for both the cases (K5 +ve and -ve). Thus, from the above results it is cleared that the FLC doesn't need for hard mathematical calculations and its performance is better than CPSS.

7. REFERENCES

- Kundor P., 1994: power system stability and control, McGraw-Hill, Inc.
- Anderson P. M. and Fouad A. A., 2003, Power System Control and Stability A John Wiley & Sons, Inc., Publications.
- Machowski J., J. W. Bialek, and J. R. Bumby, 2008, Power system dynamics: stability and control. Chichester: Wiley.
- Siraparapu Satyanarayana, R.K.Sharma, Mukta, and Sappa.Anil, 2014, Automatic Generation Control in Power Plant using PID, PSS and Fuzzy PID Controller, International Conference Smart Electric Grid (ISEG).
- Kamalesh Chandra Rout, 2011, Dynamic Stability Enhancement of Power System Using Fuzzy Logic Based PSS, MSc. thesis, National Institute of Technology, Rourkela, India
- Manish Kushwaha Manish Kushwaha, Ranjeeta Khare, 2013, Dynamic Stability Enhancement of Power System using Fuzzy Logic Based PSS, International Conference on Power, Energy and Control (ICPEC).
- Manish Kushwaha, Mrs. Ranjeeta Khare. 2012, Dynamic Stability Enhancement of Power System using Fuzzy Logic Based Power System Stabilizer, International Journal of Engineering Research & Technology (IJERT) Vol. 1 Issue 9.
- Sirwan A. Moahammed, Prof.Dr. Sattar B. Sadkhan, 2012, A Comparison of Mamdani and Sugeno Fuzzy Inference Systems based on Block Cipher Evaluation, International Journal of Scientific & Engineering Research, Vol. 4, Issue 12.
- Slimane Touil, Djilani Ben Attous, 2013, Effect of different membership functions on fuzzy power system stabilizer for Synchronous Machine connected to infinite bus. International Journal of Computer Applications, Vol. 71– No.7.

8. LIST OF SYMBOLS

K_s = Synchronizing torque coefficient in pu torque/rad

K_D = Damping torque coefficient in pu torque/pu speed deviation

H = Inertia constant in MW. s/MVA

$\Delta\omega_r$ = Speed deviation in pu = $(\omega_r - \omega_o) / \omega_o$

$\Delta\delta$ = Rotor angle deviation in elect.rad

s = Laplace operator

ω_o = Rated speed in elect.rad/s = $2\pi f_o = 314$ for a 50 Hz system

FIS = Fuzzy Interference System

PSS= Power System Stabilizer

FLPSS= fuzzy logic power system stabilizer

CPSS= conventional power system stabilizer

SMIB= Single Machine Infinite Bus



S.M= synchronous machine

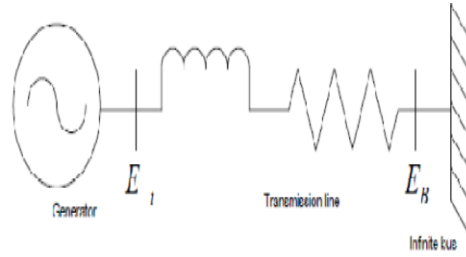

Figure 1. equivalent circuit of Synchronous Machine connected to infinite bus, Kundor P. ,1994.

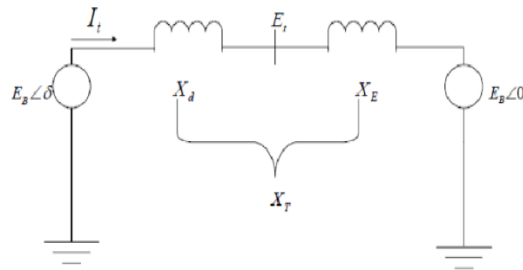

Figure 2. Classical model of generator.

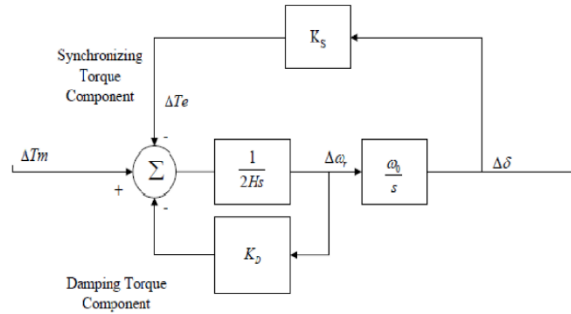

Figure 3. Block diagram of single machine infinite bus system with classical model.

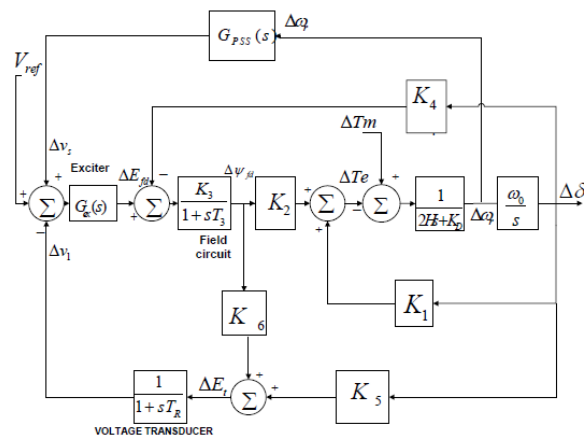

Figure 4. Block diagram representation with AVR and PSS.

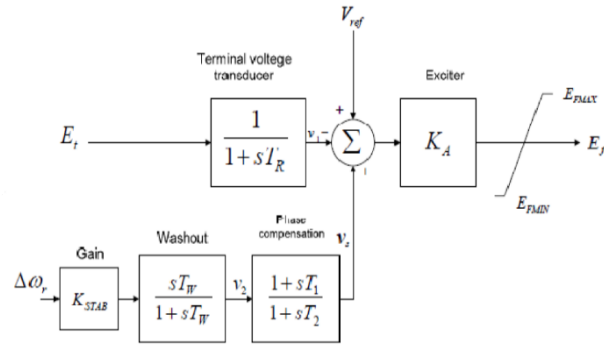

Figure 5. Thyristor excitation system with AVR and PSS. J. Machowski, J. W. Bialek, and J. R. Bumby.

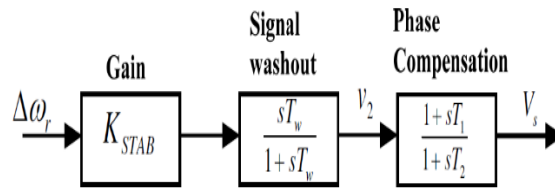

Figure 6. Block diagram of conventional PSS.

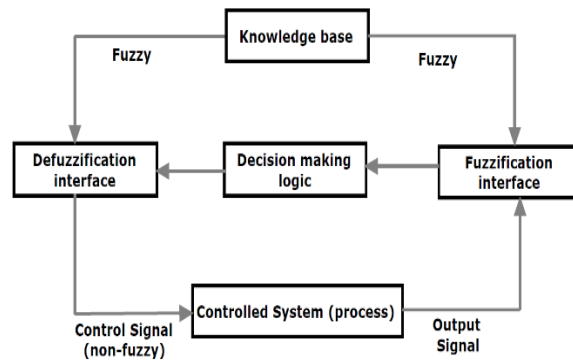

Figure 7. Fuzzy logic system.

Table 1. Membership functions for fuzzy variables.

NB	NEGATIVE BIG
NM	NEGATIVE MEDIUM
NS	NEGATIVE SMALL
ZE	ZERO
PS	POSITIVE SMALL
PM	POSITIVE MEDIUM
PB	POSITIVE BIG

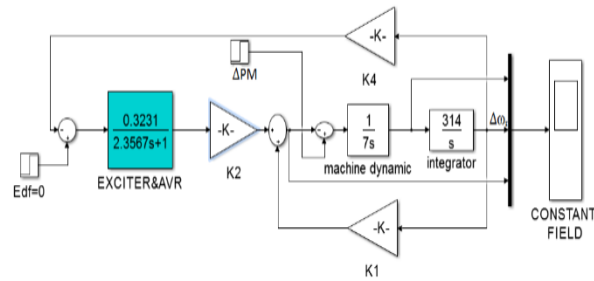

Figure 8. Simulink model for simulation of single machine infinite bus System with constant field voltage.

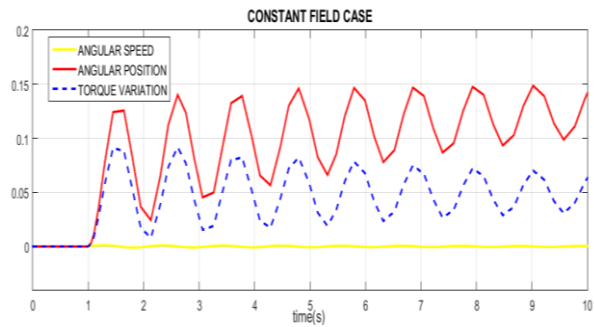

Figure 9. system response for a 5% change in mechanical input with constant field only.

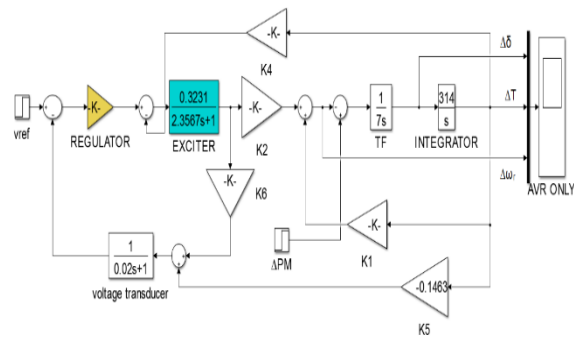

Figure 10. Simulink model for simulation of single machine infinite bus system with AVR only.

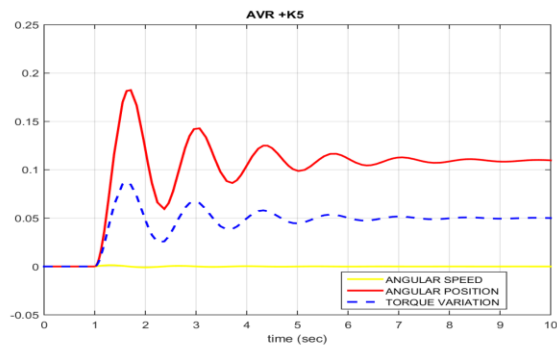

Figure 11. System response for a 5% change in mechanical input with K5 positive.

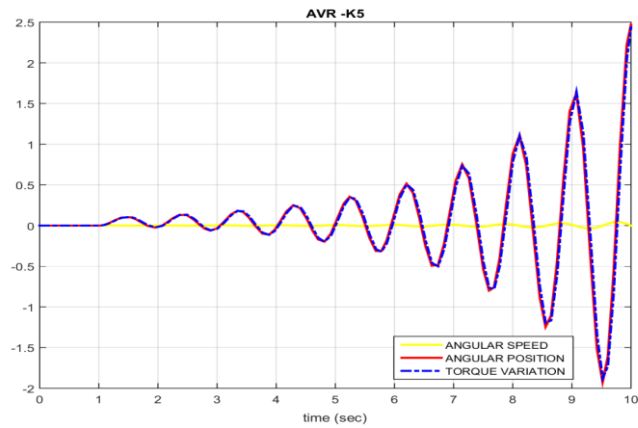

Figure 12. System response for a 5% change in mechanical input with K5 negative.

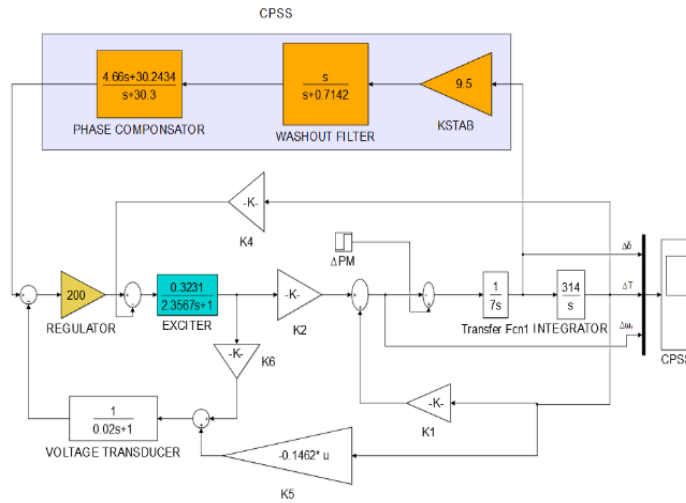

Figure 13. Simulink Model with AVR and PSS.

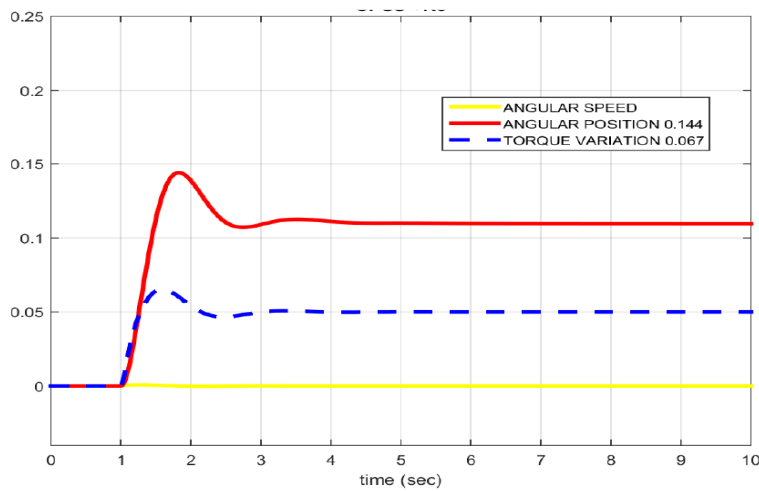

Figure 14. Variation of angular speed and angular position and torque when PSS (lead-lag) is applied with K5 positive.

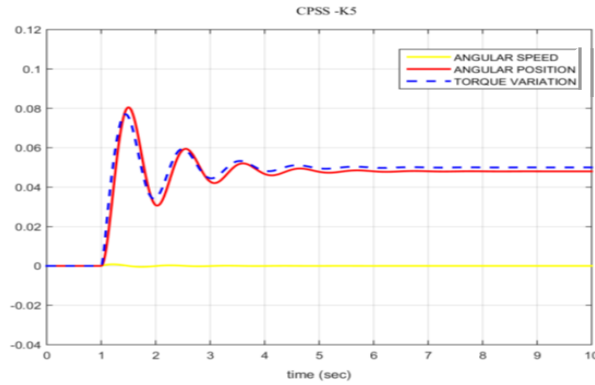

Figure 15. Variation of angular speed, angular position and torque when PSS (lead-lag) is applied with K5 negative.

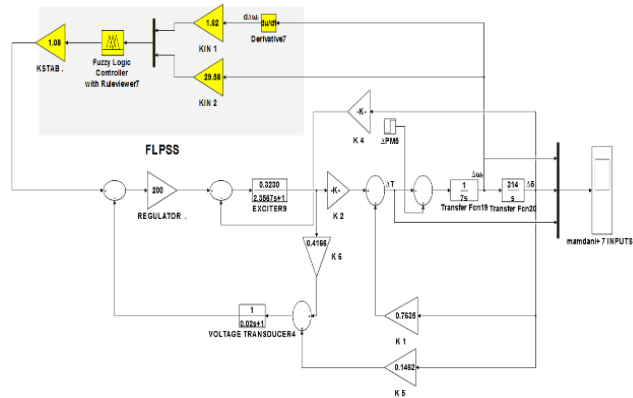

Figure 16. Simulink model with fuzzy logic based PSS.

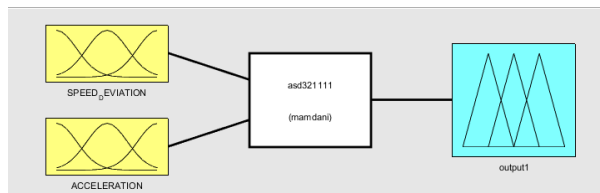

Figure 17. Mamdani Fuzzy Inference System.

Table 2. Rule Base for Fuzzy Logic Controller.

Speed Deviation	Acceleration						
	NB	NM	NS	ZE	PS	PM	PB
NB	NB	NB	NB	NB	NM	NM	NS
NM	NB	NM	NM	NM	NS	NS	ZE
NS	NM	NM	NS	NS	ZE	ZE	PS
ZE	NM	NS	NS	ZE	PS	PS	PM
PS	NS	ZE	ZE	PS	PS	PM	PM
PM	ZE	PS	PS	PM	PM	PM	PB
PB	PS	PM	PM	PB	PB	PB	PB

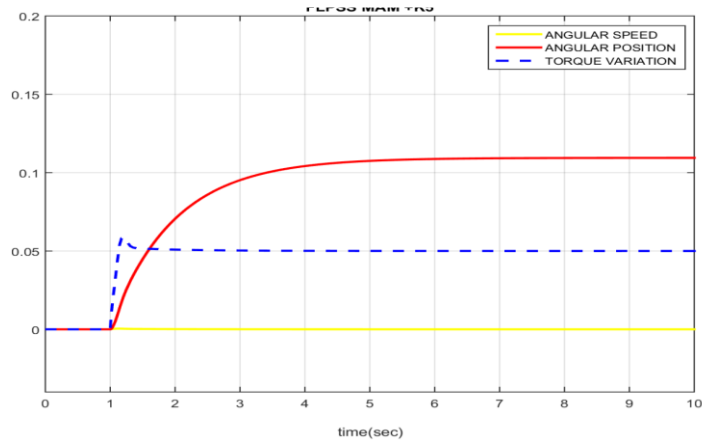

Figure 18. FLPSS with 5% mechanical changes when K5 is positive Mamdani interference.

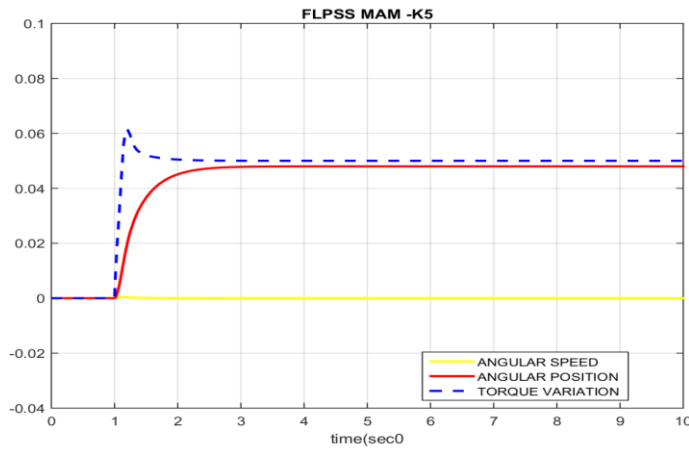

Figure 19. FLPSS with 5% mechanical changes when K5 is negative mamdani interference.

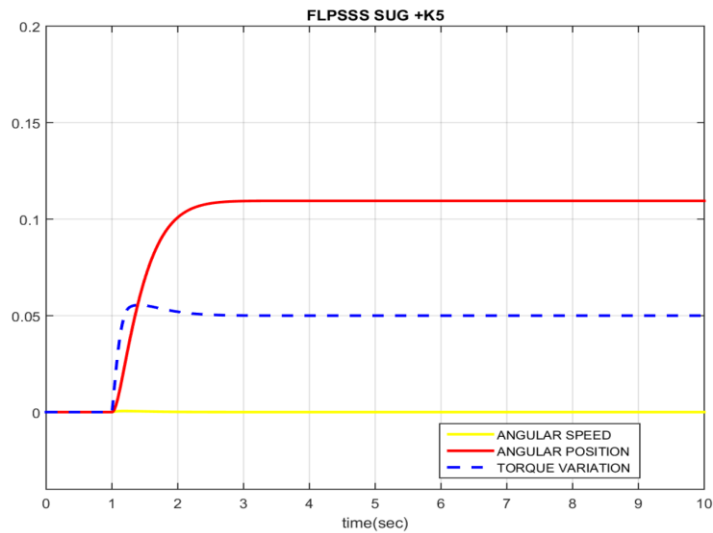

Figure 20. FLPSS with 5% mechanical changes when +K5 is SUGGENO membership.

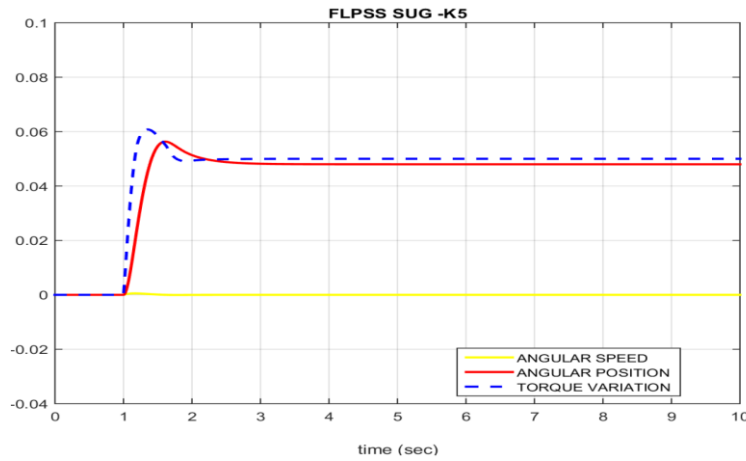

Figure 21. FLPSS with 5% mechanical changes when -K5 is SUGGENO membership.



Figure 22. Angular speed for mamdani and sugeno membership function comparison.

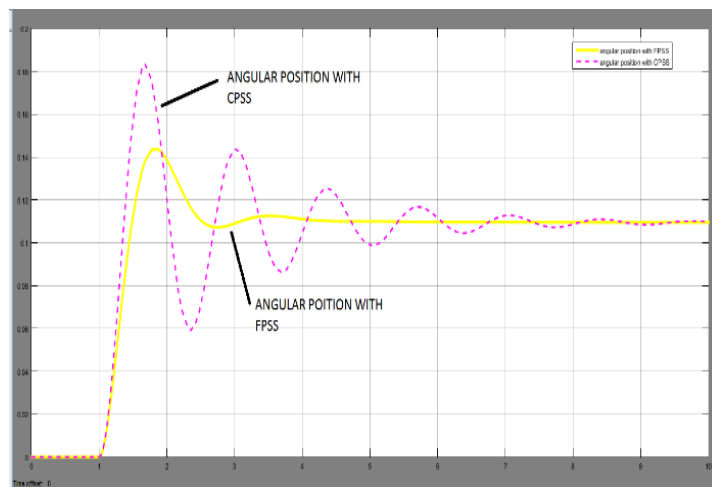

Figure 23. Comparison of angular position with CPSS & FLPSS when K5 is positive.

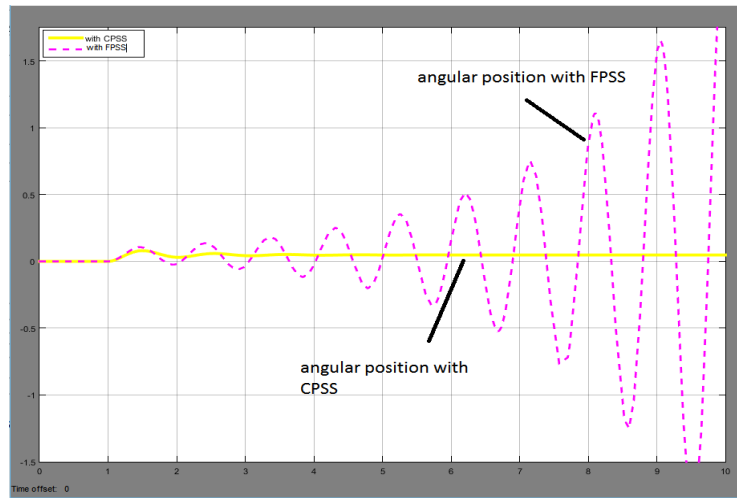

Figure 24. Comparison of angular position with CPSS & FLPSS when K5 is negative.

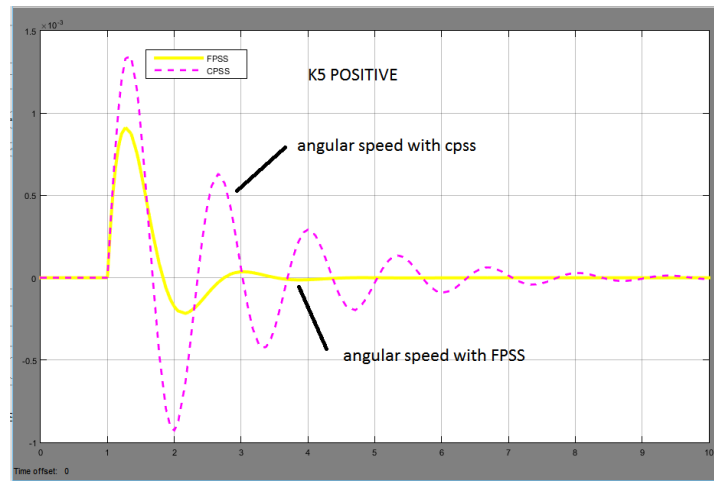

Figure 25. Comparison of angular speed with CPSS & FLPSS when K5 is positive.

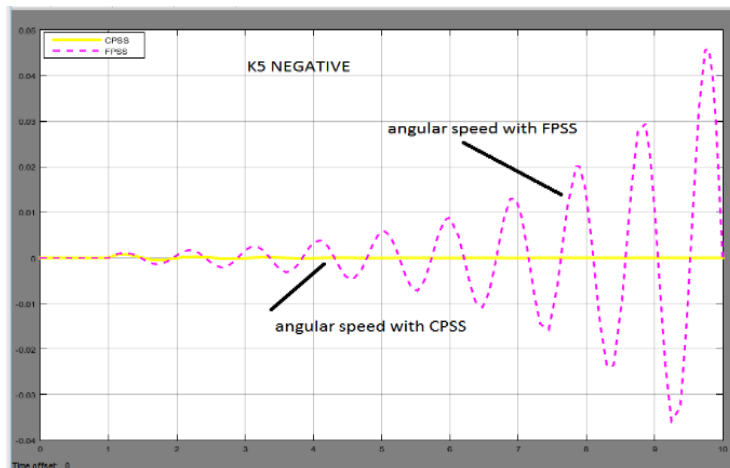

Figure 26. Comparison of angular speed with CPSS & FLPSS when K5 is negative.