

***Electrical, Electronics and communications, and Computer Engineering***

**Estimating Angle of Arrival (AOA) for Wideband Signal by Sensor Delay Line (SDL) and Tapped Delay Line (TDL) Processors**

**Dr. Bassim Sayed Mohammed**  
Communication Eng. Dept.  
University of Technology  
email: [bassim\\_sayed@yahoo.com](mailto:bassim_sayed@yahoo.com)

**Dalya Khalid Hasan**  
Electrical Eng. Dept.  
University of Technology  
email: [daliarahim@ymail.com](mailto:daliarahim@ymail.com)

**ABSTRACT**

Angle of arrival (AOA) estimation for wideband signal becomes more necessary for modern communication systems like Global System for Mobile (GSM), satellite, military applications and spread spectrum (frequency hopping and direct sequence). Most of the researchers are focusing on how to cancel the effects of signal bandwidth on AOA estimation performance by using a transversal filter (tap delay line) (TDL). Most of the researchers were using two elements array antenna to study these effects. In this research, a general case of proposed (M) array elements is used. A transversal filter (TDL) in phase adaptive array antenna system is used to calculate the optimum number of taps required to compensate these effect. The proposed system uses a phase adaptive array antenna in conjunction with LMS algorithm to work an angle of arrival (AOA) estimator for wideband signals rather than interference canceller. An alternative solution to compensate for the effect of signal bandwidth is proposed by using sensor delay line (SDL) instead of fixed delay unit since it has variable time sampling in the time domain and not fixed time delay, depending on the angle of arrival of received signals. The proposed system has the ability to estimate two parameters for received signals simultaneously (the output Signal to Noise Ratio (SNR) and AOA), unlike others systems which estimate AOA only. The comparison of the simulation results with Multiple Signal Classification (MUSIC) technique showed that the proposed system gives good results for estimating AOA and the output SNR for wideband signals. (SDL) processor shows better performance result than (TDL) processor. MUSIC technique with both (SDL) and (TDL) processors shows unacceptable results for estimating (AOA) for the wideband signal.

**Keywords:** Angle of arrivals estimation (AOA), Wideband signal, Transversal Filter (TDL), Adaptive Array Antenna, sensor delay lines (SDL), MUSIC algorithm.

**تخمين زاوية الوصول للإشارات ذات الحزم العريضة من قبل المعالجات تأخير زمن وصول الإشارة (TDL) وعناصر هوائي ملحقه للحصول على زمن تأخير متغير (SDL).**

داليا خالد حسن  
قسم الهندسة الكهربائية  
الجامعة التكنولوجية

دياسم سعيد محمد  
قسم هندسة الاتصالات  
الجامعة التكنولوجية

**الخلاصة**

اصبح تخمين زاوية الوصول (AOA) للإشارة عريضة النطاق ضرورية جدا لأنظمة الاتصالات الحديثة مثل النظام العالمي للهاتف المتنقل (GSM) والاقمار الاصطناعية والتطبيقات العسكرية وطيف الحزم العريضة ( frequency hopping and )



(direct sequence). يركز معظم الباحثين على إلغاء تأثير عرض النطاق الترددي للإشارة المستلمة باستخدام مرشح متعامد (transversal filter) (TDL). كان معظم الباحثين يستخدمون مصفوفة الهوائي من عنصرين لدراسة هذه الآثار. في هذا البحث استخدمنا الحالة العامة المقترحة لعناصر مصفوفة هوائيات بعدد (M) مع transversal filter (TDL) في نظام مصفوفة هوائية طور متكيفه وتم حساب العدد المثالي من اعداد taps المطلوبه لإلغاء هذه التأثيرات. في النظام المقترح استخدمنا مصفوفات هوائية طور متكيفه مع خوارزمية LMS للعمل على تخمين زاوية الوصول (AOA) للإشارات عريضة النطاق بدلا من عملها كمنظومه الغاء التداخلات. تم اقتراح حل بديل لإلغاء تأثير عرض نطاق الإشارة باستخدام عناصر هوائية ملحقه مع كل عنصر اساسي في المصفوفه للحصول على زمن تأخير متغير ( $T_s$  variable sampling time) (SDL) بدلا من زمن تأخير ( $T_0$ ) ثابت وحدة تأخير. للحصول على فترات زمنية متغيرة في المجال الزمني وليس فترات تأخير زمنية ثابتة تبعا لزاوية وصول الإشارات المستلمة. نظامنا المقترح لديه القدرة على تخمين نسبة الإشارة الى الضوضاء (SNR) و زاوية الوصول (AOA) للإشارات العريضة بنفس الوقت، على عكس الانظمة الأخرى التي تخمن زاوية الوصول (AOA) فقط. أظهرت نتائج المقارنة للمحاكاة مع تقنية MUSIC أن النظام المقترح يعطي نتائج جيدة في تخمين زاوية الوصول (AOA) و (SNR) للإشارات عريضة النطاق باستخدام (SDL) و (TDL) و أظهرت النتائج أن النظام مع (SDL) أفضل. أظهرت تقنية MUSIC مع كل من المعالجات (SDL) و (TDL) نتائج سيئة لتخمين (AOA) للإشارة عريضة النطاق.

**الكلمات الرئيسية:** اشاره ذات الحزم العريضة, تخمين زاوية الوصول, مصفوفة هوائية متكيفه, مرشح متعامد (TDL), عناصر هوائي زمن تأخير (SDL), خوارزمية MUSIC.

## 1. INTRODUCTION

Beamforming has found many implementations in different areas such as sonar, radar and wireless communications **Griffiths, 1983**. In the past, most of the works have mainly focused on signals of narrowband, in recent signals of broadband have received more attention. This can be fundamentally attributed to the superior performance of beamforming. For the reason that each signal of broadband consists of many components of various frequencies, the beamforming weights should be various for various frequencies, thus increasing the computational complexity **Li, et al., 2017, Liu and Weiss, 2010**. However, when the signal bandwidth increases, the AOA estimation performance will degrade, as a solution to the degradation of performance the tapped delay line (TDL) (transversal filter) (or FIR/IIR filters in its discrete form) are often used to improve the performance of adaptive beamformer for bandwidth, **Jafari, et al., 2013, Gu, et al., 2005, and Lin, et al., 2007**. For processing wideband tap delay line filter with digital beamforming processing technique is required to use with each channel to get a channel transfer function  $H(j\omega)$  function of signal bandwidth **Zhang, et al., 2010, and Goncharova, et al., 2011**.

The most popular AOA algorithm is (MUSIC technique) which is used to estimate the direction of arrival (DOA) for narrowband signals. This technique exploits the smallest subspace Eigenvectors extracted from covariance matrix of received signal ( $\Phi_{xx}$ ) to estimated (DOA) of signal. For wideband signal, it is found that all Eigenvectors of covariance matrix are occupied by the components of received signal and no longer Eigenvalues exist for channel thermal noise which are needed by MUSIC DF formula to estimate the angle. It is found that the TDL length (number of taps), is depending on the impinging signals bandwidth. The largest the bandwidth the more delay line taps are required. The delay between taps is decrease due to the increase signal bandwidth. As a result, very high speed digital sampling circuits or analogue TDLs have to be utilized for signals with very large bandwidth **Vook and Compton, 1990, Lin et al., 2010**. Referenced to MUSIC technique, the transversal filter method is eliminates the signal bandwidth effects and give good results approximately a like with narrowband signal. MUSIC technique fails to give satisfied results for wideband signal even with the use of transversal filter **Mohammed and Noori, 2014**.

A new structure of broadband beamforming is proposed, by using traditional tapped delay line TDLs and by using sensor delay lines (SDLs) as an alternative solution to compensate spatial propagation delays between sensors **Lin, et al., 2008, and Liu, 2009**.



The organization of this paper is as follows, in section 2, MUSIC algorithm is reviewed. In section 3 introduce a mathematical formulation for two broadband processor presented and analyzed for tapped delay line (TDL) (transversal filter) and sensor delay line (SDL). Processes output signal to noise ratio (SNR) for the proposed system is derived. Simulation results are presented in Section 4, and conclusions are drawn in Section 5.

## 2. MUSIC TECHNIQUE

The MUSIC technique is simple, popular, high resolution and efficient Eigen structure method for AOA estimation. The MUSIC spatial spectrum can be expressed as **Kumbar, 2015**

$$P_{MUSIC}(\theta) = \frac{1}{\mathbf{a}^H(\theta) \mathbf{E}_N \mathbf{E}_N^H \mathbf{a}(\theta)} \quad (1)$$

Where  $\mathbf{a}(\theta)$  is the steering vector given by  $[g_i(\theta)e^{-j\beta id \cos(\theta)}]^T$  for  $i = 1, 2, \dots, M$ ,  $g_i(\theta)$  is the element field pattern and  $\theta$  is a spatial angle belonging to  $[0, 2\pi]$  and  $\mathbf{E}_N$  is a thermal noise sub space eigen vector related to the set of equal and smallest eigen value of orthogonalized received signals covariance matrix ( $\Phi_{xx}$ ).

## 3. MATHEMATICAL PRELIMINARIES FOR BROADBAND PROCESSOR.

For M element adaptive arrays composed of isotropic antenna elements separated by (d) distance at the carrier frequency  $\omega_0$  impinging on a broadband signal with bandwidth  $\Delta\omega_s$  as shown in the **Fig.1**.

The received signals vector  $\mathbf{X}_m$  and weight vector  $\mathbf{W}_m$  at the  $I$  delays behind each element can be expressed as **Liu et al., 2014**

$$\mathbf{X}_m = [x_{m1}, x_{m2}, \dots, x_{mI}]^T \quad (2)$$

$$\mathbf{W}_m = [w_{m1}, w_{m2}, \dots, w_{mI}]^T \quad (3)$$

where T is a transpose,  $\mathbf{X}_m$  is element signal vector and  $\mathbf{W}_m$  the element weight vector. Then the total signal  $\mathbf{X}$  and weight  $\mathbf{W}$  vectors can be expressed as

$$\mathbf{X} = [\mathbf{X}_1^T \quad \mathbf{X}_2^T \quad \dots \quad \mathbf{X}_M^T]^T \quad (4)$$

$$\mathbf{W} = [\mathbf{W}_1^T \quad \mathbf{W}_2^T \quad \dots \quad \mathbf{W}_M^T]^T \quad (5)$$

The optimal weight vector for the array is then given by **Compton, 1988**

$$\mathbf{W}_{opt} = \Phi_{xx}^{-1} \mathbf{a} \quad (6)$$

where  $\Phi_{xx}$  is the signal covariance matrix and  $\mathbf{a}$  is the steering vector.

The received signal by each element consists of received and thermal noise signals at tap  $I$  behind each M-element has the form

$$\mathbf{X}_{(m,i)}(t) = \mathbf{X}_s(m,i)(t) + \mathbf{X}_n(m,i)(t) \quad (7)$$

where  $\mathbf{X}_{s_{mi}}(t)$ ,  $\mathbf{X}_{n_{mi}}(t)$  are receive and thermal noise signals, respectively. The element signal vectors  $\mathbf{X}_m$  and the total signal vector  $\mathbf{X}$  can be expressed as

$$\mathbf{X}_m = \mathbf{X}_{s_m} + \mathbf{X}_{n_m} \quad (8)$$

$$\mathbf{X} = \mathbf{X}_s + \mathbf{X}_n \quad (9)$$

The received signal at each sensor is assumed to consist of two uncorrelated component: receive signal underestimation process from unknown angle  $\theta_s$  and noise channel component. The signal covariance matrix  $\Phi_{xx}$  of array system performed from two matrices corresponding to the receive matrix signal  $\Phi_{ss}$  and noise matrix  $\Phi_{nn}$ , respectively since they are mutually independent

$$\Phi_{xx} = \Phi_{ss} + \Phi_{nn} \quad (10)$$

Where each  $(I \times I)$  sub matrix  $\Phi_{ss(m,n)}$  is the receive signal covariance matrix associated with a pair of element signal vector  $\mathbf{X}_{s_m}$  and  $\mathbf{X}_{s_n}$

$$\Phi_{ss(m,n)} = E[\mathbf{X}_{s_m}^* \mathbf{X}_{s_n}^T] \quad (11)$$



If the received signal is assumed to have flat power spectral density amplitude of  $(2\pi P_s/\Delta\omega_s)$  over a limited bandwidth  $\Delta\omega_s$  center at  $\omega_o$  as shown in **Fig.2**. The power spectrum auto correlation function is given by

$$\Phi_{ss}(\omega) = E[\mathbf{X}_s^*(\omega) \cdot \mathbf{X}_s^T(\omega)] \quad (12)$$

Since there is a Fourier transformer relationship between power spectrum correlation matrix and autocorrelation function in time domain given by

$$R_{xx}(\tau) = \int_{-\frac{\Delta\omega_s}{2}}^{\frac{\Delta\omega_s}{2}} \Phi_{xx}(\omega) e^{j\omega\tau} d\omega \quad (13)$$

The autocorrelation function of the received signal for flat power spectrum density is then given by **Li, et al., 2017**

$$R_{ss}(\tau) = P_s \text{sinc}\left(\frac{\Delta\omega_s \tau}{2}\right) e^{j\omega_o \tau} \quad (14)$$

### 3.1 Broadband Processor with Tapped Delay Line (TDL).

Such transversal filter can be realized by a tapped delay line having complex weight as shown in **Fig.3**. Each element is followed by a tapped delay line with  $I$  taps of time delay  $T_o$  seconds between taps.

Then the total time delay at arbitrary tap is

$$\mathbf{X}_{s(m,i)}(t) = \mathbf{X}_s(t - [i - 1]T_o - [m - 1]T_e) \quad (15)$$

where  $T_o$  is the delay unit time between adjacent element taps ( $i = 1, 2, \dots, I$ ) and  $T_e$  is the unit propagation delay between adjacent array element ( $m = 1, 2, \dots, M$ ). The thermal noise signal is given by

$$\mathbf{X}_{n(m,i)}(t) = \mathbf{X}_n(t - [i - 1]T_o) \quad (16)$$

The  $(ik^{th})$  terms of  $\Phi_{ss(m,n)}$  (the element in the  $(i^{th})$  row and  $(k^{th})$  column of  $\Phi_{ss(m,n)}$ ) can be found by the following formula as

$$[\Phi_{ss(m,n)}]_{i,k} = R_{ss}[(m - n)T_e + (i - k)T_o] \quad (17)$$

where

$$R_{ss}(\tau) = E[\mathbf{x}_s^*(t) \cdot \mathbf{x}_s(t + \tau)] \quad (18)$$

If the received signal is incident on the array from  $\theta_s$  then

$$T_e = \frac{d}{c} \sin(\theta_s) = \frac{\pi}{\omega_{max}} \sin(\theta_s) \quad (19)$$

If we choose  $T_o$  equivalent to a time required by receive signal to across a distance  $d1$  equal to a quarter wavelength at center frequency then we have

$$T_o = d1/c = \lambda_o/4c \quad (20)$$

Now the equivalent phase delay between signals at different taps due to delay time  $T_o$  at a center frequency is

$$\varphi_o = T_o \omega_o = \frac{\pi}{2} \quad (21)$$

Substituting Eq.'s.(18), (19) and (20) into (17) leads to **Lin et al., 2007**

$$[\Phi_{ss(m,n)}]_{i,k} = P_s \text{sinc}\left(\frac{\Delta\omega_s}{2} \{(m - n)T_e + (i - k)T_o\}\right) * e^{j\omega_o[(m - n)T_e + (i - k)T_o]} \quad (22)$$

The product of  $\Delta\omega_s T_e$  can be normalized over a center frequency  $\omega_o$  to have absolute relative bandwidth as follows

$$\Delta\omega_s T_e = (\Delta\omega_s/\omega_o) * \omega_o T_e = Bw_s \varphi_e \quad (23)$$

Where  $Bw_s$  is the received signal relative bandwidth and  $\varphi_e$  is the inter element phase delay at center frequency, using Eq. (19),  $\varphi_e$  can be expressed as a function of inter element spacing and receive signal angle of arrival as

$$\varphi_e = \beta d \sin(\theta_s) = (2\pi/\lambda_o) d \sin(\theta_s) \quad (24)$$

For  $d = \lambda_o/2$  Eq. (24) becomes



$$\varphi_e = \pi \sin(\theta_s) \quad (25)$$

By the same way

$$\Delta\omega_s T_o = (\Delta\omega_s / \omega_o) * \omega_o T_o = Bw_s \varphi_o \quad (26)$$

Where  $\varphi_o$  is a phase delay due to tap time delay  $T_o$ . Using Eq.'s (21),(22), (23) and (25) then (26) becomes

$$[\Phi_{ss(m,n)}]_{i,k} = P_s \text{sinc} \left( \frac{Bw_s}{2} \tau_s \right) * e^{j\tau_s} \quad (27)$$

Where the receive delay time is equal to

$$\tau_s = [\pi(m-n) \sin(\theta_s) + (\pi/2)(i-k)] \quad (28)$$

Where  $m, n = 1, 2, \dots, M$  Sensors;  $i, k = 1, 2, \dots, I$  Taps.

The components of channels thermal noise are considered to be mutually uncorrelated for array sensor and but mutually correlated in the same channel (i.e. between delay taps). flat spectrum is the study case for wideband signal and thermal noise with amplitude  $(2\pi\sigma^2/\Delta\omega)$  over signal and thermal noise bandwidth  $Bw_n$ . The correlation matrix of noise can be derived utilizing the same steps as for receive signal, only final equations will be listed as follows

$$[\Phi_{nn(m,n)}]_{i,k} = \begin{cases} \Phi_{nn}[(i-k)T_o] \dots \text{for } m = n \\ 0 \dots \dots \dots \text{for } m \neq n \end{cases} \quad (29)$$

$$[\Phi_{nn(m,m)}]_{i,k} = \sigma^2 \text{sinc} \left( \frac{\Delta\omega_n}{2} (i-k)T_o \right) * e^{j\omega_o(i-k)T_o} \quad (30)$$

Where  $\sigma^2$  is the variance of thermal noise component

$$[\Phi_{nn(m,m)}]_{i,k} = \sigma^2 \text{sinc} \left( \frac{Bw_n}{2} \tau_n \right) * e^{j\tau_n} \quad (31)$$

Where  $\tau_n$  is the noise delay time and equal to

$$\tau_n = [(\pi/2)(i-k)] \quad (32)$$

Now all element of  $\Phi_{xx}$  can be calculated.

The steering vector ( $\mathbf{a}$ ) can also be calculated, by using the same steps, constraint steering vector of dimension  $(MI \times 1)$  for whole array can be written as

$$[\mathbf{a}_{(m,1)}]_{i,1} = \text{sinc} \left( \frac{\Delta\omega_a}{2} [(m-1)T_e + (i-1)T_o] \right) * e^{j\omega_o[(m-1)T_e + (i-1)T_o]} \quad (33)$$

$$[\mathbf{a}_{(m,1)}]_{i,1} = \text{sinc} \left( \frac{Bw_a}{2} \tau_a \right) * e^{j\tau_a} \quad (34)$$

where  $\tau_a$  is a steering vector delay time equal to

$$\tau_a = [\pi(m-1) \sin(\theta_a) + (\pi/2)(i-1)] \quad (35)$$

Where  $m, n = 1, 2, \dots, M$  sensor;  $i, k = 1, 2, \dots, I$  taps.  $\theta_a$  is a steering angle belongs to  $[0, 2\pi]$  and  $Bw_a$  is the relative bandwidth of steering vector, and its value is taken to be equal to the designed system bandwidth. Then  $\mathbf{W}_{opt}$  given by Eq. (6) can now be found as a function of receive and noise bandwidth as well as a function of receive signal angle of arrival. When a steering vector angle  $\theta_a$  is equal to the angle of  $i^{th}$  received signals( $\theta_{is}$ ), the output of the system will be maximum from this direction which represents AOA estimation. With the optimized weight, the output powers due to received signals and the thermal noise are

$$P_s(\theta_s, Bw_s) = \mathbf{W}_{opt}^T \Phi_{ss(\theta_s, Bw_s)} \mathbf{W}_{opt} \quad (36)$$

$$P_n(Bw_n) = \mathbf{W}_{opt}^T \Phi_{nn(Bw_n)} \mathbf{W}_{opt} \quad (37)$$

Finally, the output signal to noise ratio (SNR) as a function of signal bandwidth and angle of arrival is equal to

$$SNR(\theta_s, Bw_s) = \frac{P_s(\theta_s, Bw_s)}{P_n(Bw_n)} \quad (38)$$

### 3.2 Alternative Approach for Broadband Processor by Sensor Delay Line (SDL).



As shown in **Fig. 4**, the spacing between the sensor at the position  $(m, i)$  and the one at  $(m + 1, i)$ ,  $i = 1, 2, \dots, I$  is the same, and the spacing between the sensor at the position  $(m, i)$  and the one at  $(m, i + 1)$ ,  $m = 1, 2, \dots, M$ , is the same too **Liu, 2009, Yu et al., 2007**.

The total time delay at line sensors is

$$\mathbf{X}_s(m,i)(t) = \mathbf{X}_s(t - [i - 1]T_s - [m - 1]T_e) \quad (39)$$

Where  $T_s$  is the unit propagation delay between adjacent delay-line sensors ( $i = 1, 2, \dots, I$ ) and  $T_e$  is the unit propagation delay between adjacent array element ( $m = 1, 2, \dots, M$ ).

The correlation matrix of the signal received at the  $(m, i)^{th}$  and  $(n, k)^{th}$  sensor is given by

$$\begin{aligned} [\Phi_{ss(m,n)}]_{i,k} &= E[\mathbf{X}_{s_m}^* \mathbf{X}_{s_n}^T] \\ &= \mathbf{R}_{ss}[(m - n)T_e + (i - k)T_s] \end{aligned} \quad (40)$$

To avoid spatial aliasing it is often assumed that two adjacent array elements are half a wavelength apart from each other at the maximum signal frequency,  $\omega_{max}$ .

The two adjacent delay-line sensors are  $r$  times a quarter wavelength apart from each other at  $\omega_{max}$ . The unit propagation delay between delay-line sensors is given by

$$T_s = \frac{d1}{c} \cos(\theta_s) = \frac{\pi}{2\omega_{max}} r \cos(\theta_s) \quad (41)$$

Where  $d1$  is the spacing between adjacent SDL sensors. Substituting Eq. (18) into Eq. (40), gives

$$[\Phi_{ss(m,n)}]_{i,k} = P_s \text{sinc} \left( \frac{\Delta\omega_s}{2} \{ (m - n)T_e + (i - k)T_s \} \right) * e^{j\omega_o[(m-n)T_e + (i-k)T_s]} \quad (42)$$

Therefore the terms  $\Delta\omega_s T_e$  and  $\omega_o T_e$  can be written as

$$\Delta\omega_s T_e = \frac{\Delta\omega_s}{\omega_{max}} \pi \sin(\theta_s) = Bw_s \pi \sin(\theta_s) \quad (43)$$

and

$$\omega_o T_e = \frac{\omega_o}{\omega_{max}} \pi \sin(\theta_s) = \Omega_o \pi \sin(\theta_s) \quad (44)$$

Where  $Bw_s = \frac{\Delta\omega_s}{\omega_{max}}$  is the absolute bandwidth and  $\Omega_o = \frac{\omega_o}{\omega_{max}}$  is center frequency with their relative counterparts. Similarly,

$$\Delta\omega_s T_s = \frac{\Delta\omega_s}{\omega_{max}} \frac{\pi}{2} r \cos(\theta_s) = Bw_s \frac{\pi}{2} r \cos(\theta_s) \quad (45)$$

and

$$\omega_o T_s = \frac{\omega_o}{\omega_{max}} \frac{\pi}{2} r \cos(\theta_s) = \Omega_o \frac{\pi}{2} r \cos(\theta_s) \quad (46)$$

The autocorrelation of the received signal is

$$[\Phi_{ss(m,n)}]_{i,k} = P_s \text{sinc} \left\{ \frac{Bw_s}{2} \tau_s \right\} e^{j\Omega_o \tau_s} \quad (47)$$

Where the delay time of receive signal is equal to

$$\tau_s = \pi[(m - n) \sin(\theta_s) + (i - k)(r/2) \cos(\theta_s)] \quad (48)$$

The noise correlation matrix is given as in Eq. (31).

By using the same steps, the constraint steering vector ( $\mathbf{a}$ ) of dimension  $(MI \times 1)$  for whole array can be written as

$$[\mathbf{a}_{(m,1)}]_{i,1} = \text{sinc} \left( \frac{Bw_a}{2} \tau_a \right) * e^{j\tau_a} \quad (49)$$

Where  $\tau_a$  is a steering vector delay time equal to

$$\tau_a = \pi[m \sin(\theta_a) + i(r/2) \cos(\theta_s)] \quad (50)$$

By using the optimized weight, the output powers due to received signals and thermal noise are equal to

$$P_s(\theta_s, Bw_s) = \mathbf{W}_{opt}^T \Phi_{ss(\theta_s, Bw_s)} \mathbf{W}_{opt} \quad (51)$$

$$P_n(Bw_n) = \mathbf{W}_{opt}^T \Phi_{nn(Bw_n)} \mathbf{W}_{opt} \quad (52)$$

Finally, the output signal to noise ratio (SNR) as a function of signal bandwidth and angle of arrival is equal to



$$SNR(\theta_s, Bw_s) = \frac{P_s(\theta_s, Bw_s)}{P_n(Bw_n)} \quad (53)$$

#### 4. SIMULATION AND RESULTS

All simulation programs are written in MATLAB (8.4) and the following assumptions are considered:- omnidirectional linear array antenna uniformly distributed with  $0.5 \lambda$  inter-element spacing. The received signals are considered to be statistically independent and uncorrelated with the channel thermal noise components.

##### 4.1 CASE 1: Testing the compensation capability of the transversal processor against the effects of signal bandwidth arriving from $\theta = 70^\circ$ with input $SNR = 0dB$ . twelve isotropic array elements are assumed in this case with relative bandwidths ( $Bw_s = 40\%, 60\%$ ).

**Fig. 5.a and b** show that when the relative bandwidth of the received signal is taken to be 0.4, the output SNR is completely degraded. When six taps behind each array element have used the output SNR is significantly improved and approximately raised up to a level as the case of narrowband signals. When the relative bandwidth is increased from 0.4 to 0.6, the output SNR is dropped severely and it is found that with the increase in signal bandwidth the number of taps required to compensate the effect of this bandwidth is also increased as shown in **Fig. 5. b**.

For the case of sensor delay line processor (SDL), **Fig. 6.a and b** shows that three taps (two delay sensor) behind each array element were sufficient to compensate the effect of 0.4 relative bandwidth, while five taps (four delay sensor) are required for 0.6 relative bandwidth. From results, one can deduce that, for any value of receiving signal relative bandwidth the number of taps required by sensor delay line processor is less than the number of taps required by taped delay line processor, which means that the SDL processor is more efficient than the TDL processor but it is more complex and expensive from hardware point of view.

##### 4.2 CASE 2: Verifying the optimum number of delay taps (TDL) or sensor delay (SDL) line required for compensating the effects of two broadband signals simultaneously for AOA system with twelve isotropic array elements impinging by two signals arriving from ( $\theta_1 = 15^\circ, \theta_2 = 75^\circ$ ) with equal input SNR's 0db and relative bandwidth's ( $Bw_s = 40\%$ ) are assumed.

It can be seen from **Fig. 7**, that for 0.4 relative bandwidth the estimated angle of arrival and the level of output SNR for a signal at angle  $15^\circ$  is more influenced by the effects of signal bandwidth than the signal received from  $75^\circ$ . That is because the total phase difference parameters including relative bandwidth between array element decrease as the received signal AOA near broadside due to the decrease of  $(\cos \theta_s)$  parameter [see Eq.(41)]. Using 2 taps improves only the estimated angle of arrival and output SNR of signal from angle  $75^\circ$ , but using 6 taps shows a significant improvement in AOA and output SNR of source from  $75^\circ$  and also gives an acceptable improvement in AOA and output SNR for signal from  $15^\circ$ .

**Fig. 8**, the SDL processor exhibit better results for 0.4 relative bandwidth than the case of TDL for both sources, that is due to variation of delay time sampling ( $T_s$ ) process according to the receiving signal angles which leads to good cancellation results [see Eq.(41)].

##### 4.3 CASE 3: Testing the effect of receiving signal bandwidth on the output SNR for different number of array element (6 and 8) arriving from $\theta = 60^\circ$ with input $SNR = 0dB$ and relative bandwidth( $Bw_s = 20\%$ ).



**Fig. 9**, shows that the output SNR is mainly increased with the increase of array elements numbers for zero signal bandwidth, but when the array aperture increases, more degradation in the output SNR is shown for 0.2 relative bandwidth. This is due to the increase of signal bandwidth effects on large aperture antennas. It is found that 3 taps delay behind each array element is sufficient to compensate the effect of 0.2 relative bandwidth for both array apertures. **Fig. 10**, shows that the level of output SNR is highly improved with the increase of array elements numbers for the case of 3 taps. The results express that for a different number of an array element, the SDL processor is more efficient than the case of TDL processor since the array field pattern gain at broadside is equal to the number of array elements.

#### **4.4 CASE 4: Testing the capability of proposed system reference to the MUSIC technique for estimating AOA for two sources with ( $Bw_s = 0\%, 40\%$ ). AOA system with twelve isotropic elements impinging by two signals arriving from $\theta_1 = 40^\circ, \theta_2 = 120^\circ$ with input SNR's ( $SNR_1 = 0dB$ and $SNR_2 = 4dB$ ) is assumed.**

**Fig. 11** shows that the output SNR for zero bandwidth is proportional to the input received signal power levels. For the case when the relative bandwidth is increased to 0.4 no estimation results were seen for both output SNR's and AOA's without delay units attached to the array sensors. When 4 delay units' taps are used behind each element the system response is significantly improved for AOA estimation and partially improved for output SNR. With 6 taps the system exhibits estimating response equivalent to narrowband case response. **Fig. 12** for MUSIC DF technique response shows the two narrowband sources with (zero bandwidth) and for 0.4 relative bandwidth. The response is quite good when the bandwidths were zero and completely corrupted for 0.4 bandwidth even with the use of 4 and 6 taps behind each array elements that is because the subspace eigenvalues related to channel thermal noise which is used by MUSIC technique formula [Eq. (1)] are completely occupied by signal given values subspace  $E_s$  to meet the effect of signal bandwidth.

## **5. CONCLUSIONS**

A detailed analysis of the effect of signal bandwidth on the performance of the proposed AOA system constructed from adaptive linear array antenna has been carried out in terms of AOA and output SNR. The proposed system has been mathematically modeled, analyzed, simulated, and tested using m. file MATLAB. Comparing the tap delay line processor with the sensor delay line processor shows that the SDL processor is more efficient than the tap delay line processor since it provides a sampling time function of received signal incident angle. The number of delay sensor required to compensate any relative bandwidth effect is found to be less than the number of taps used by the transversal filter for the same bandwidth. The number of taps required for cancelling any relative bandwidth effect is increased with the increase of array sensor (array aperture) since the effect of signal bandwidth will be more for large aperture array, but for SDL a fixed number of delay sensors can be used for suppressing any relative bandwidth due to the increase in array field pattern gain with increase in the number of array elements. TDL and SDL processor exhibit good results for estimating both output SNR and AOA. MUSIC technique shows unacceptable results with wideband signals even with the use of (TDL) and (SDL) processors behind each element.

## **6. REFERENCES**

- Carusone, A. and Johns, D.A., 2000. *Analogue Adaptive Filters: Past and Present*. IEE Proceedings-Circuits, Devices, and Systems, Vol. 147, No. 1, pp.82-90.
- Compton, R.T., 1988. *The Bandwidth Performance of a Two-Element Adaptive Array with Tapped Delay-Line Processing*. IEEE Transactions on Antennas and Propagation, Vol. 36, No. 1, pp.5-14.





- Goncharova, A.A., Weber, R.J. and Huang, Y., 2011, March. *Sparse Array DOA Estimation in the Presence of Unknown Non-Uniform Noise*. In Aerospace Conference, IEEE (pp. 1-8).
- Griffiths, J.W.R., 1983, February. *Adaptive Array Processing. A Tutorial*. In IEE Proceedings H-Microwaves, Optics and Antennas. IET (Vol. 130, No. 1, p. 3).
- Gu, J., Stark, H. and Yang, Y., 2005. *Design of Tapped-Delay Line Antenna Array Using Vector Space Projections*. IEEE Transactions on Antennas and Propagation, Vol. 53, No. 12, pp.4178-4182.
- Jafari, A.H., Liu, W. and Morgan, D.R., 2013. *Study of Sensor Positions for Broadband Beamforming*. IEEE Signal Processing Letters, Vol. 20, No. 8, pp.779-782.
- Kumbar, K.A., 2015. *Adaptive Beamforming Smart Antenna for Wireless Communication System*. Int Res J Eng Technol, Vol. 2, No. 3, pp.2038-2043.
- Li, Y., McLernon, D. and Zaidi, A., 2017, January. *Analysis of the Least Squares Approach to Broadband Beamforming*. In Recent Advances in Signal Processing, Telecommunications & Computing (Sigtelcom), International Conference on, IEEE. (pp. 11-15).
- Lin, N., Liu, W. and Langley, R., 2007, July. *Performance Analysis of a Broadband Beamforming Structure without Tapped Delay-Lines*. In Digital Signal Processing, International Conference on, IEEE. (pp. 583-586).
- Lin, N., Liu, W. and Langley, R., 2008, March. *Performance Analysis of a Two-Element Linearly Constrained Minimum Variance Beamformer with Sensor Delay-Line Processing*. In Acoustics, Speech and Signal Processing. ICASSP. IEEE International Conference on (pp. 2601-2604).
- Lin, N., Liu, W. and Langley, R.J., 2010. *Performance Analysis of an Adaptive Broadband Beamformer Based on a Two-Element Linear Array with Sensor Delay-Line Processing*. Signal Processing, Vol. 90, No. 1, pp.269-281.
- Liu, C., Hu, D. and Zhao, Y., 2014, August. *A Novel Adaptive Wideband Beamformer Based on Uniform Linear Array*. In General Assembly and Scientific Symposium (URSI GASS), XXXIth URSI. IEEE (pp. 1-4).
- Liu, W. and Weiss, S., 2010. *Wideband Beamforming: Concepts and Techniques* (Vol. 17). John Wiley & Sons.
- Liu, W., 2009. Adaptive wideband beamforming with sensor delay-lines. Signal Processing, 89(5), pp.876-882.
- Mohammed, B.S. and Noori, N.H., 2014, April. *The angle of Arrival and Signal to Noise Ratio Estimation for Broadband Signals by Phased Adaptive Array Antennas*. In Antennas and Propagation (EuCAP), European Conference on, IEEE (pp. 347-351).
- Vook, F.W., and Compton, R.T., 1990, May. *The Bandwidth Performance of Linear Adaptive Arrays with Tapped Delay-Line Processing*. In Antennas and Propagation Society International Symposium, IEEE. AP-S. Merging Technologies for the 90's. Digest. (pp. 1692-1695).
- Yu, L., Lin, N., Liu, W. and Langley, R., 2007, March. *Bandwidth Performance of Linearly Constrained Minimum Variance Beamformers*. In Antenna Technology: Small and Smart Antennas Metamaterials and Applications, IEEE. IWAT'07. International Workshop on (pp. 327-330).
- Zhang, H., Ma, X., Cheng, Y. and Bai, Y., 2010, October. Study on DOA estimation algorithm for the smart antenna of uniform circular. In Computer Application and System Modeling (ICCASM), International Conference on, IEEE. (Vol. 15, pp. V15-627).

## NOMENCLATURE



$\mathbf{a}(t)$ : Steering vector.  
 $Bw_s$ : Received signal relative bandwidth.  
 $Bw_n$ : Thermal noise relative bandwidth.  
 $c$ : Velocity of signal  
 $\mathbf{E}_N$ : Subspace eigenvector related to noise subspace  
 $g_M(\theta_s)$ : Antenna element field pattern  
 $p_n$ : Thermal noise power  
 $p_s$ : Received signal power  
 $\mathbf{W}_{opt}$ : Optimum weight vector  
 $T_e$ : Spatial propagation time delay between adjacent array elements of the SDL  
 $T_o$ : Time delay between taps  
 $T_s$ : Time delay between adjacent sensors.  
 $y(t)$ : Array output voltage due to signals and thermal noise  
 $\Phi_{ss}$ : Power spectrum density of the receive signal  
 $\Phi_{nn}$ : Power spectrum density of thermal noise  
 $\Phi_{xx}$ : Power spectrum density for received signals plus thermal noise.  
 $R_{ss}(\tau)$ : Auto correlation function of the receive signal.  
 $\tau$ : Integrator time constant  
 $\lambda$ : Center frequency wavelength of received signal  
 $\beta$ : Wave number  
 $\tau_s$ : Delay time of receive signal  
 $\tau_n$ : Delay time of thermal noise  
 $\tau_a$ : Delay time of steering vector  
 $\varphi_o$ : Tap delay line phase different  
 $\varphi_e$ : Inter element phase delay at center frequency  
 $\theta_s$ : Elevation angle of received signal  
 $\sigma^2$ : Variance of thermal noise (noise power)  
 $E\{.\}$ : Expected value of  $\{.\}$   
 $[.]^{-1}$ : Inverse matrix  
 $\{.\}^*$ : Conjugate  
 $\{.\}^T$ : Transpose of vector.  
AOA: Angle of Arrival  
SNR: signal to noise ratio  
TDL: Tap Delay Line  
SDL: Sensor Delay Line  
MUSIC: Multiple Signal Classification  
FIR: Finite impulse response  
IIR: Infinite impulse response

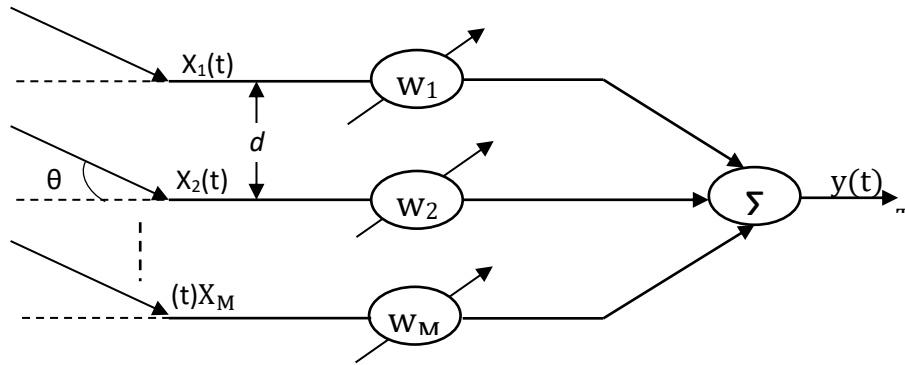

Figure 1. An adaptive narrowband beam former.

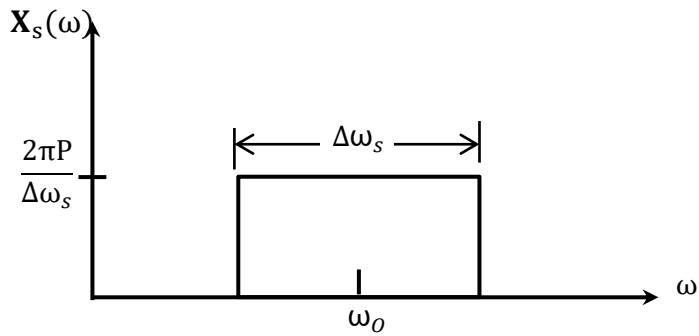

Figure 2. Power spectral density.

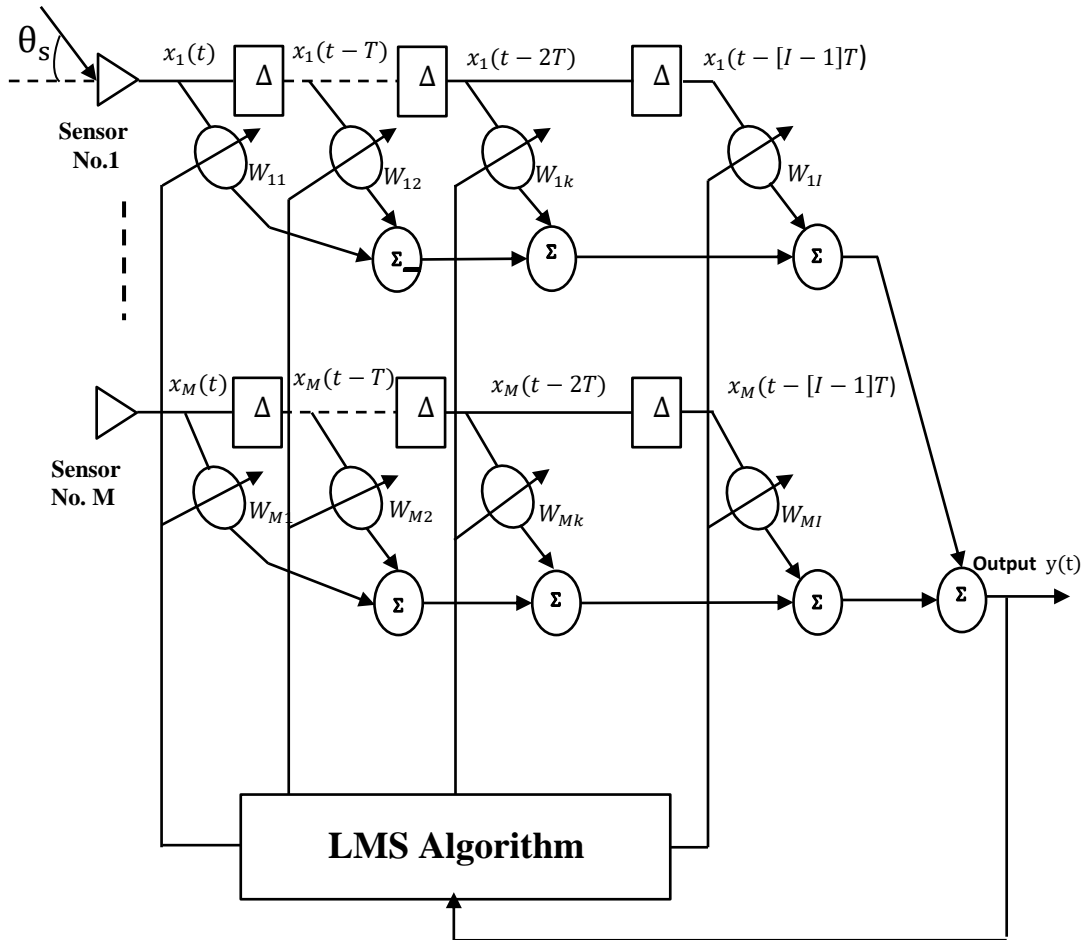

Figure 3. Wideband adaptive array AOA estimator.

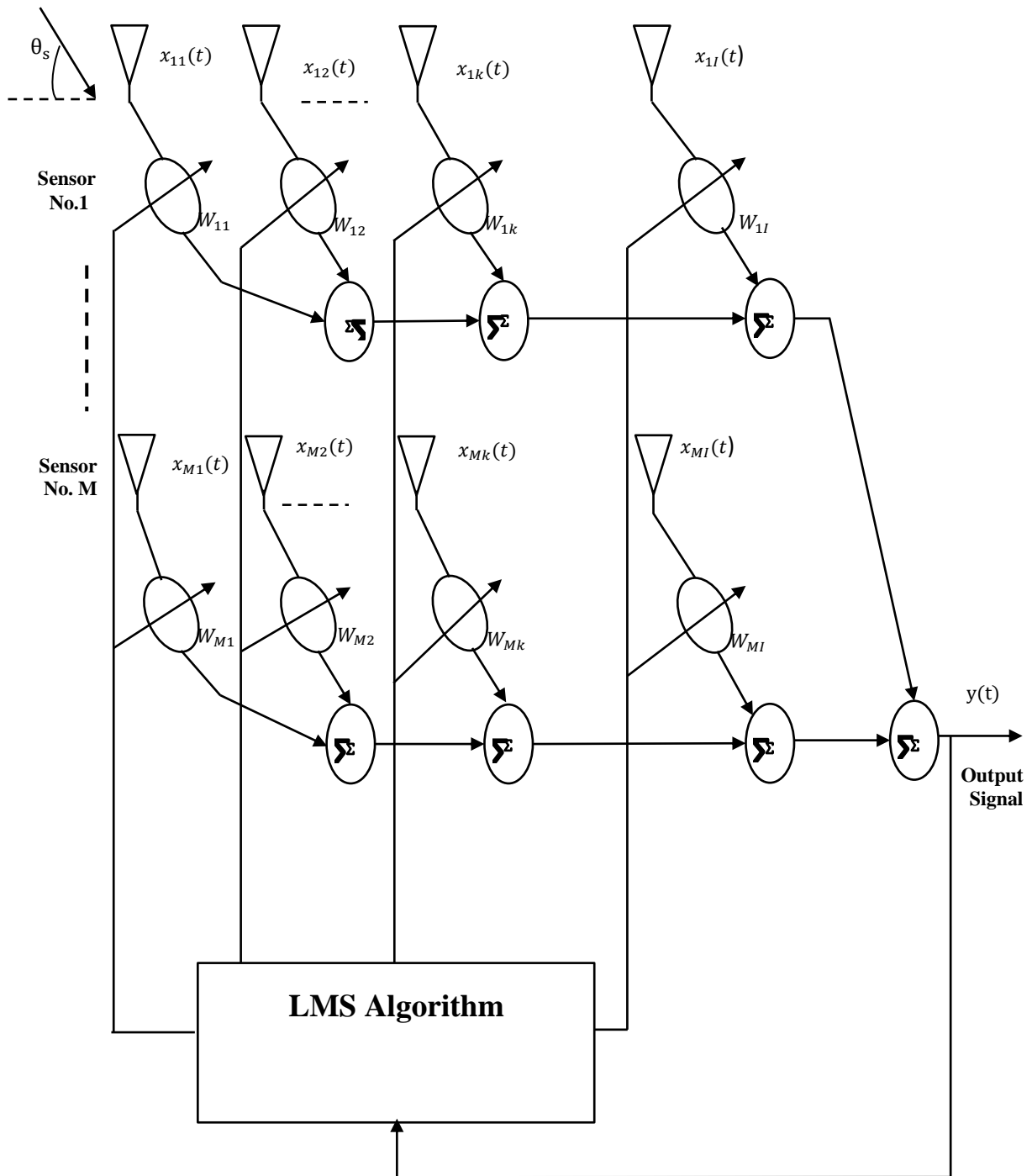
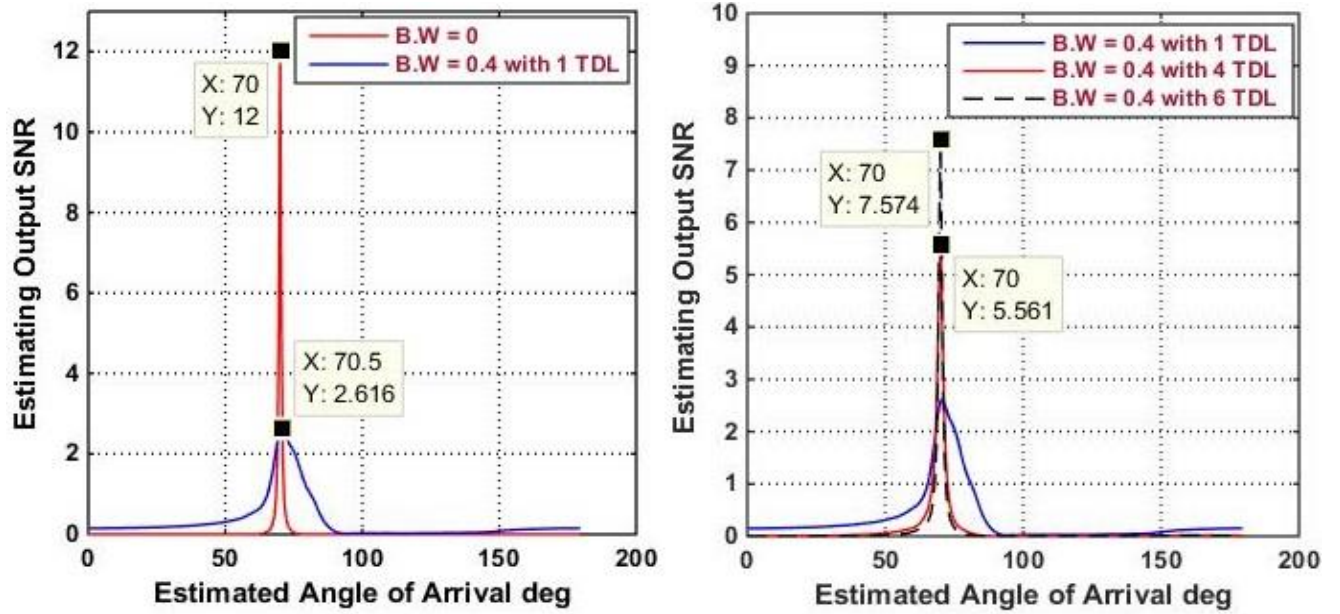
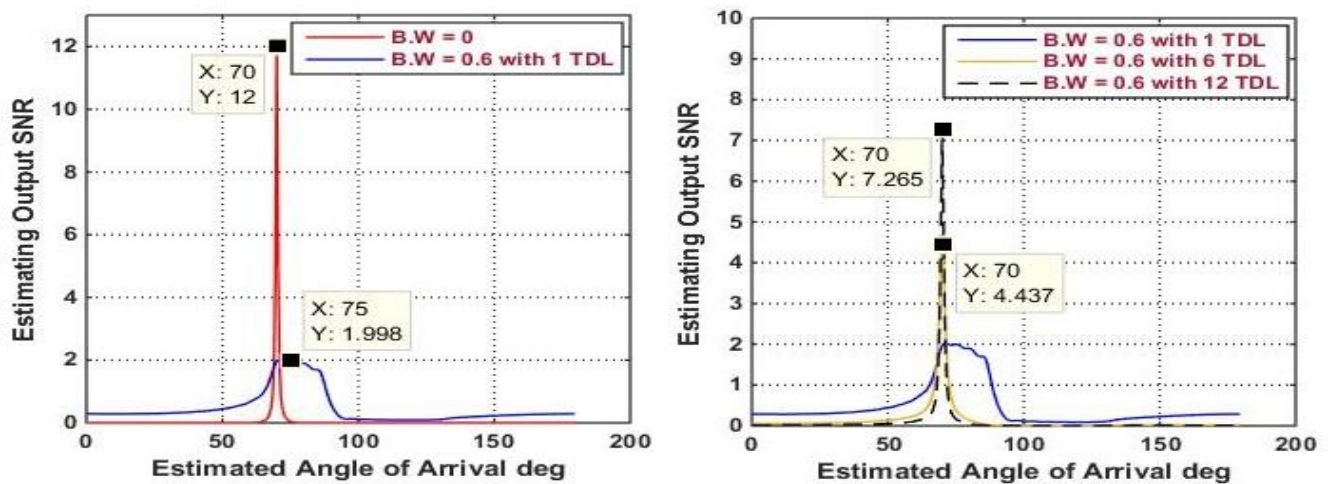

Figure 4. Sensor-Delay Line Processor.



a. with relative bandwidth 40%.



b. with relative bandwidth 60%.

Figure 5. Output SNR plot for an adaptive system with TDL processor with relative bandwidth 40% and 60%.

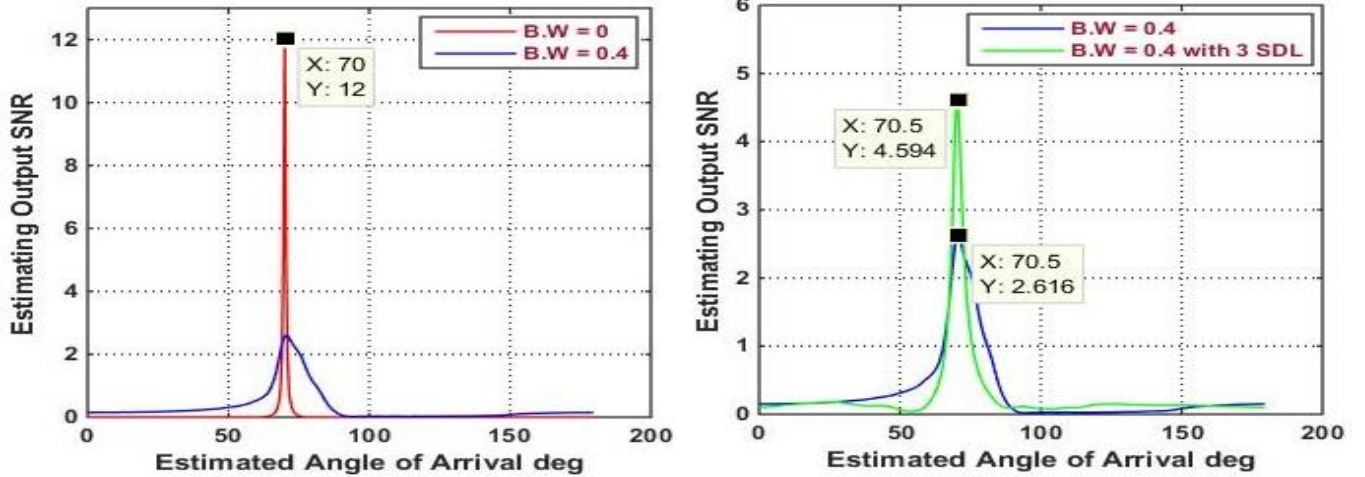

a. with relative bandwidth 40%.

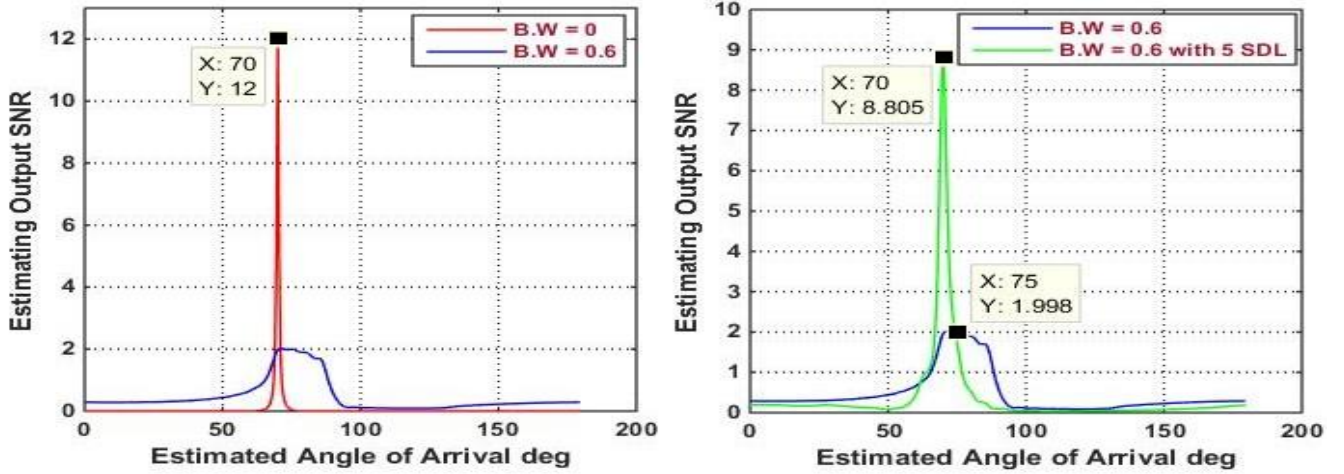

b. with relative bandwidth 60%.

Figure 6. Output SNR plot for an adaptive system with SDL processor with relative bandwidth 40% and 60%.

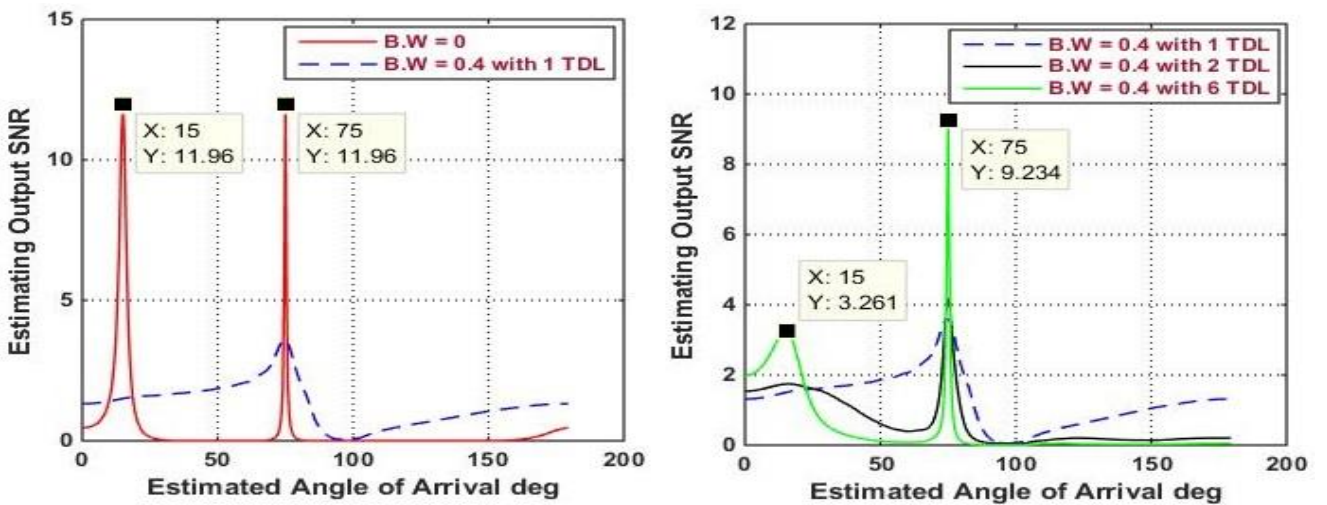

Figure 7. Output SNR plot for an adaptive system with TDL processor with two sources.

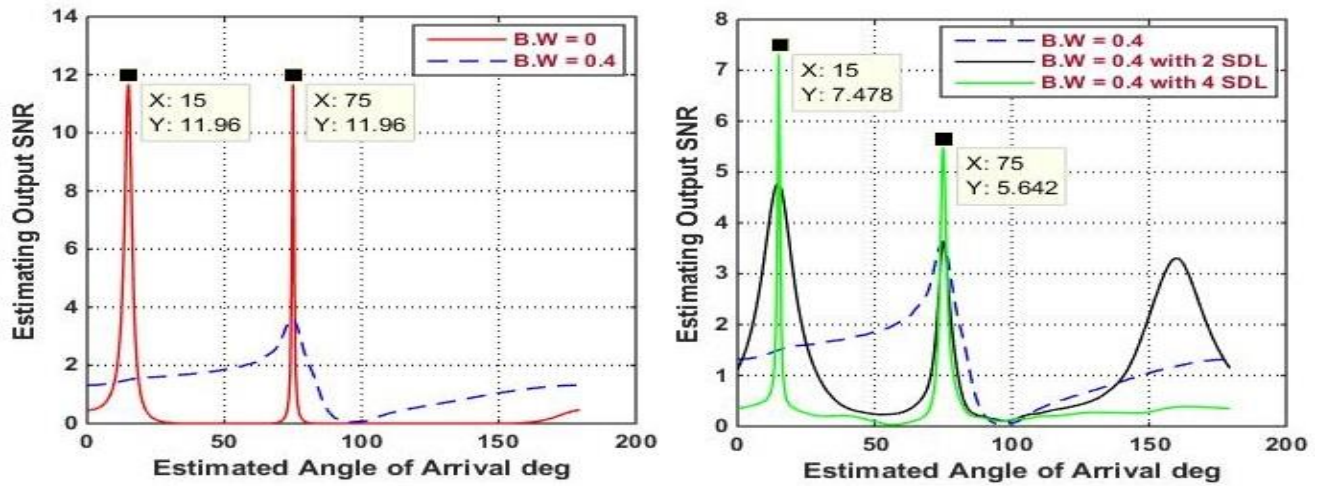

Figure 8. Output SNR plot for an adaptive system with SDL processor with two sources.

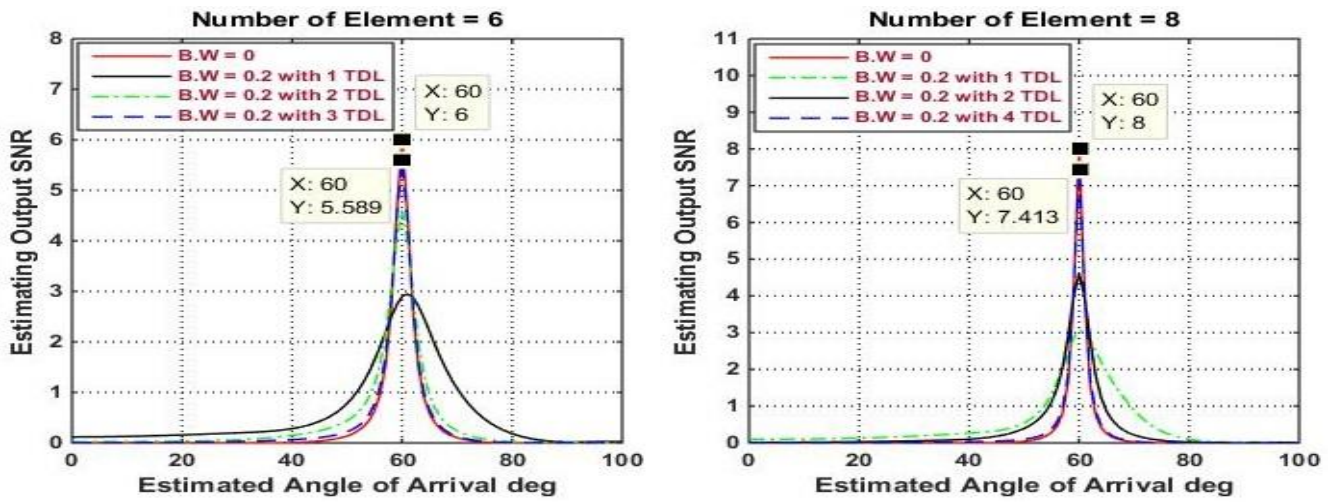

Figure 9. Output SNR plot for an adaptive system with TDL processor for a different number of antennas.

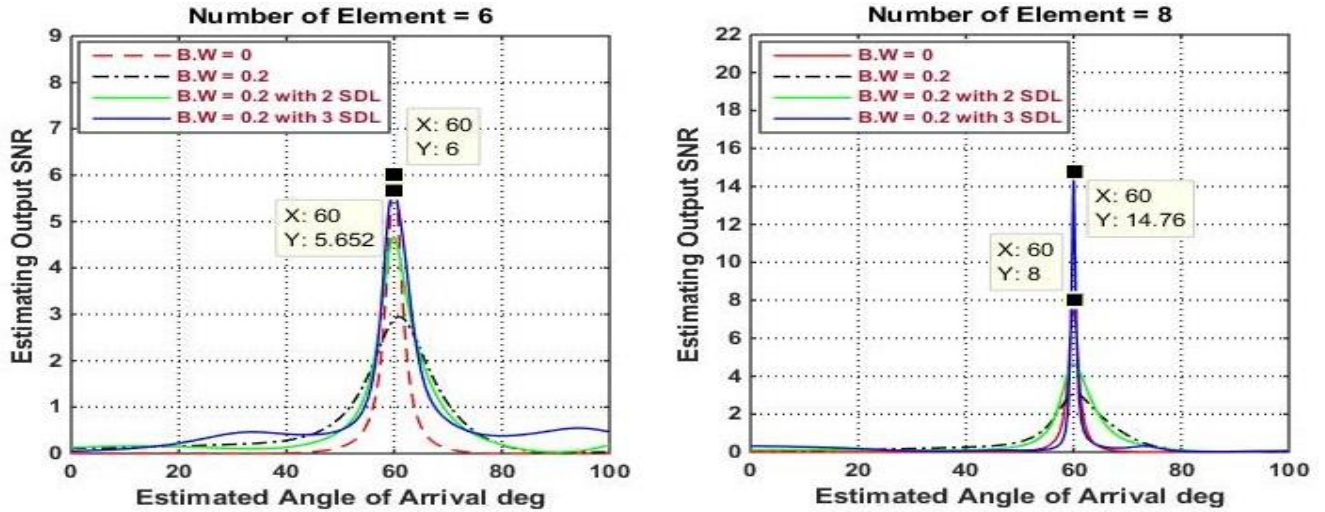

Figure 10. Output SNR plot for an adaptive system with SDL processor for a different number of antennas.

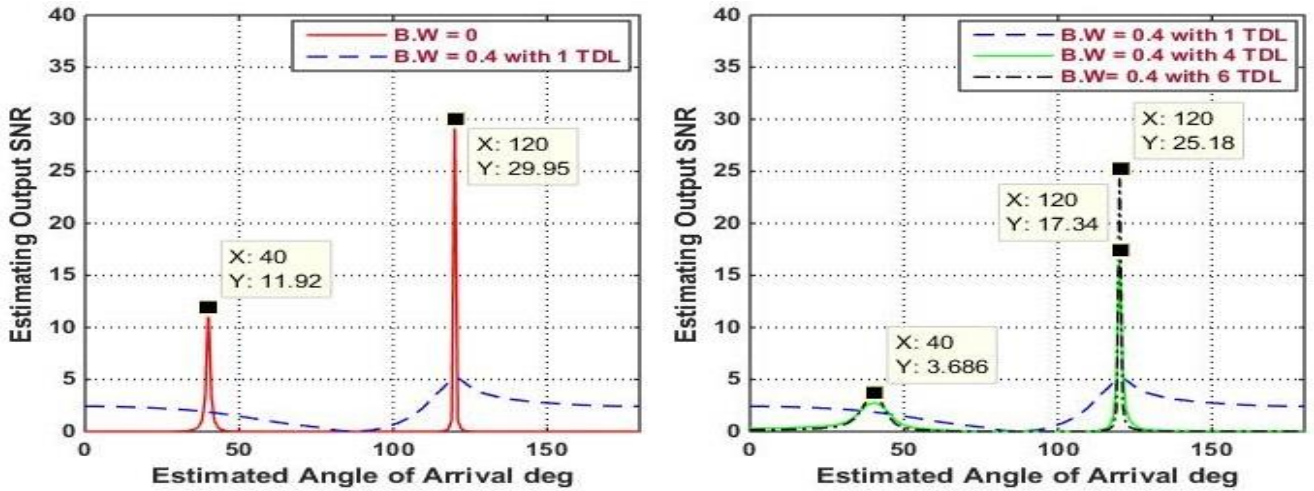

Figure 11. The proposed system plot for output SNR with two sources.

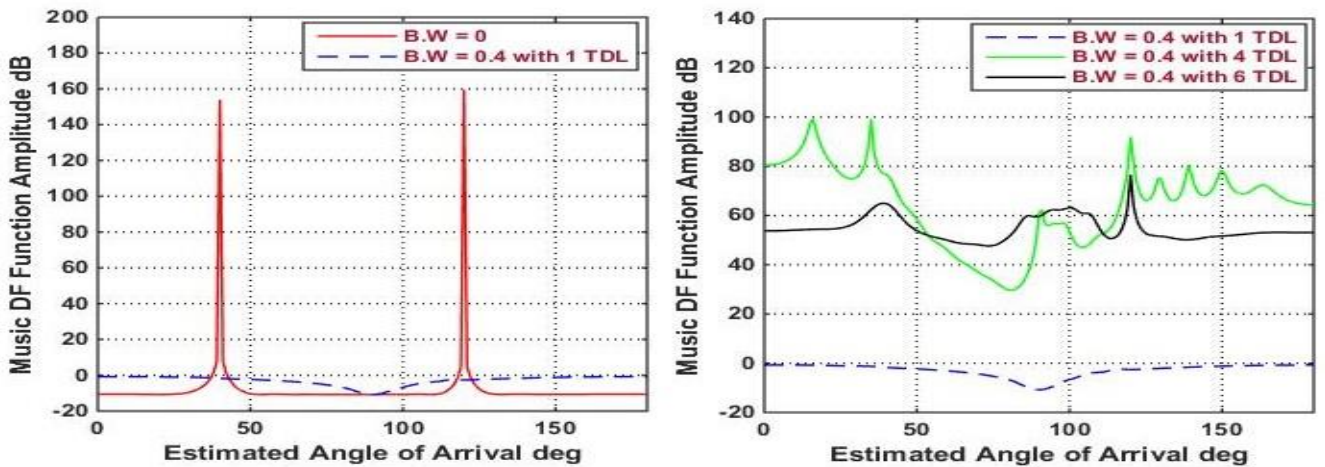

Figure 12. MUSIC DF response with two sources.