

Civil and Architectural Engineering

**EFFECT OF DAM HEIGHT ON THE STABILITY OF EARTH DAM
(CASE STUDY: KAROLINKA DAM)**

Somia Abdallah Bredy

Ph.D. student

Institute of Water Structures- College of Civil
Engineering

Brno University of Technology
Czech Republic

E-mail: bredy.s@fce.vutbr.cz

Jan Jandora

Assoc. professor

Institute of Water Structures- College of Civil
Engineering

Brno University of Technology
Czech Republic

E-mail: jandora.j@fce.vutbr.cz

ABSTRACT

The Karolinka earth-fill dam was constructed between 1977 and 1984 on the Stanovnice river above the town of Karolinka in the region of Vsetínsko in Czech Republic. Because of leakage on the downstream dam face due to technological indiscipline when filling dam layers during the dam construction stage, there were some steps to improve state dam safety. The final rehabilitation is to construct the diaphragm walls from self-hardening cement-bentonite suspension along the length of the dam. In addition to connecting the gallery and abutment (2 × 25 m long) by using jet piles. The article presents numerical modeling of safety factor evaluation associated with the state of the dam body and foundation; before, and after sealing. Also, studying the effect of dam height on its stability by using finite element method is performed by the Plaxis 3D program in the case study of Karolinka dam. It is concluded that measured data shows good agreement with the computed result.

Keywords: Diaphragm walls, Jet grouting, Finite Element Method, Slope stability, Safety factor.

تأثير ارتفاع السد على استقرار السد الترابي (سد كارولينكا)

سمية عبدالله البريدي

طالبة دكتوراه

كلية الهندسة المدنية – جامعة برنو التقنية

يان ياندورا

أستاذ مساعد- نائب عميد الكلية

كلية الهندسة المدنية – جامعة برنو التقنية

الخلاصة

تم بناء سد كارولينكا بين عامي 1977 و1984، على نهر ستانوفنيتس بالقرب من مدينة كارولينكا في منطقة فتسينسكوفي الجمهورية التشيكية. وبسبب التسرب على وجه السد الخلفي والحاصل نتيجة الإهمال التكنولوجي أثناء مرحلة بناء السد، كانت هناك بعض الخطوات لتحسين أمان السد، حيث تم إعادة التأهيل عن طريق بناء جدران استنادية من البنتونيت الأسمنتي المتصلب على طول السد. إضافة إلى الربط بين النفق والنواة (بطول 2 × 25 م) على جانبي السد باستخدام اعمدة الجت. تقدم هذه المقالة النمذجة العددية لتقييم عامل الأمان المرتبط بحالة جسم السد والأساس؛ قبل وبعد الختم باستخدام طريقة العناصر المحددة التي يتم تنفيذها بواسطة برنامج Plaxis 3D حيث أظهرت النتائج توافقاً مع القيم المقاسة. **الكلمات الرئيسية:** الجدران الاستنادية، طريقة الجت، طريقة العناصر المحددة، توازن المنحدرات، عامل الأمان.

*Corresponding author

Peer review under the responsibility of University of Baghdad.

<https://doi.org/10.31026/j.eng.2020.03.10>

2520-3339 © 2019 University of Baghdad. Production and hosting by Journal of Engineering.

This is an open access article under the CC BY4 license <http://creativecommons.org/licenses/by/4.0/>.

Article received:7/5/2019

Article accepted:25/6/2019

Article published:1/3/2020

1. INTRODUCTION

The Limit equilibrium LE (conventional slip circle analysis) has been used for analyzing the slope stability and geotechnical structures safety since 1930. LE methods are based on some assumptions about the sliding surface shape, and it is one of the most popular methods because of their simplicity, with no need for many parameters. The typical output from a LE analysis is SF. LE methods sum forces and moments related to an assumed slip surface passed through a soil mass. It assumes a slip surface and the soils along this surface, providing shear resistance. Although LE methods do not take into account the soil behavior, it is important to make an initial stability assessment for simple problem geometries using LE software (Abramson, et al., 2002). Conversely, the problems of complex geometries, or those that require seepage analysis, consolidation, and fully coupled flow-deformation analysis, FEM would be better (Fattah, et al., 2016). It demonstrates the geometry of failure surfaces, clear the deformations in soils with their exact place, and simulate failure mechanism as well. In FEM, failure occurs naturally through the zones where the applied shear stress exceeds the shear strength; thus, no assumption about the shape or location of the failure surface. In this study, a slope stability analysis was presented for two cases: 1- Diaphragm walls in the middle (dam height 39.1m), 2- Jet piles in the end at both sides of dam (dam height 11.06m) using numerical modeling with Plaxis program. 10-node tetrahedral elements and the Mohr-Coulomb yield criterion are used (Bredy, et al., 2019).

2. CASE STUDY

Karolinka dam was constructed between 1977 and 1984, to supply the cities of Vsetín and Vlára with pure and wholesome water, protect from floods, and generate hydroelectric energy. The first filling of the reservoir of Karolinka dam was in year of 1986. Karolinka dam is earth-fill dam made of local gravel materials with a vertical clay gravelly core surrounded on both sides, by filters of gravel, the zones of face are formed by gravel sand, and the upstream face is reinforced with macadam filled with bitumen. 39.1 meters high, 392 meters long, 1: 2.2 - 2.4 downstream slopes, 1:3.3 upstream slope with reservoir volume of 7.521 million cubic meters and basin area of 23.1 square kilometers. The reservoir water level was specified as a level 2.9 m below the crest of the dam (Pařílková, et al., 2016, and Hodak, 2014). The diaphragm wall was constructed from self-hardening cement bentonite suspension along the length of the dam. The total length of the diaphragm walls is 301.75. The depth of the diaphragm walls ranges from 10.50 m to 19.30 m.

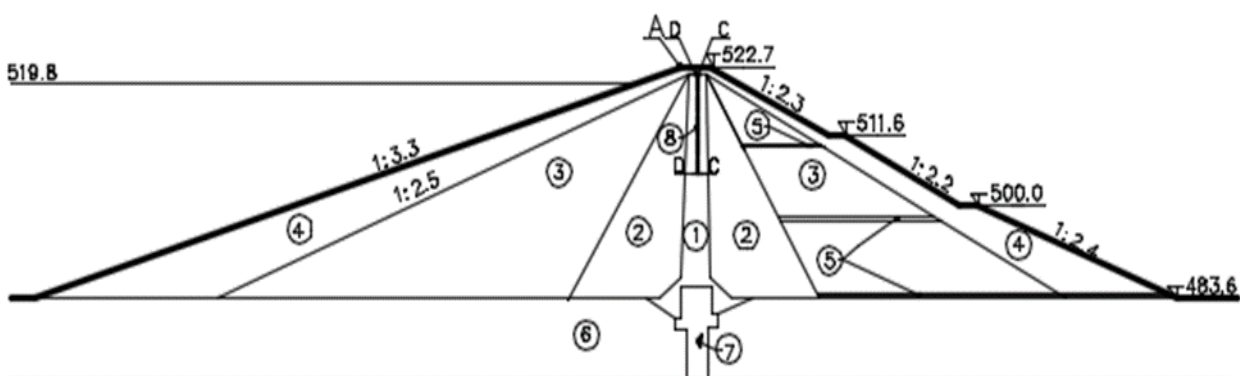

Figure 1. Cross- Section of Karolinka dam (diaphragm wall).

The width of the diaphragm wall is 0.60 m. The length of the diaphragm wall is 3.60 m. **Fig. 1** shows the cross-section of Karolinka dam.

Legend

1. Core clay gravelly, 2. Zone 2B Gravel with fine-grained soil, 3. Zone 2A Gravel with loam, 4. Zone 3. Gravel with fine-grained soil, 5. Gravel drain, 6. Gravel with loam, 7. Curtain grouting, 8. Diaphragm wall

Additional sealing has been conducted for connecting the gallery and abutment (2×25 m long) by using jet pile with a diameter of 1 m and overlap of 0.2 m, from a cement- bentonite mixture, **Fig. 2**.

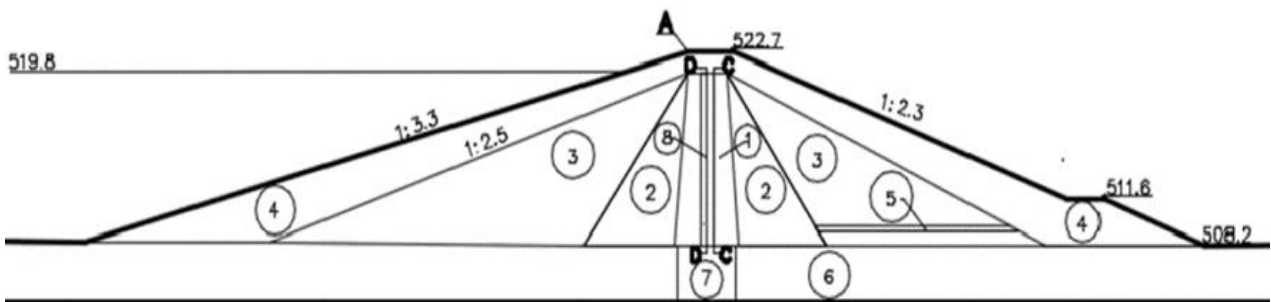

Figure 2. Cross- Section of Karolinka dam (jet pile).

Legend

1. Core clay gravelly, 2. Zone 2B Gravel with fine-grained soil, 3. Zone 2A Gravel with loam, 4. Zone 3. Gravel with fine-grained soil, 5. Gravel drain, 6. Gravel with loam, 7. Curtain grouting, 8. Jet pile.

3. NUMERICAL MODELLING

3.1 Constitutive model

The constitutive model used in this study is linear-elastic perfectly plastic with Mohr-Coulomb failure criterion (Aljorany, et al., 2014). Mohr-Coulomb failure criterion can be written as the equation for the line that represents the failure envelope (Labuz, et al., 2012):

$$\tau = \sigma' \tan \varphi' + \dot{c} \quad (1)$$

Where τ is shear stress, σ' is effective normal stress, φ' is an effective angle of internal friction and \dot{c} is effective cohesion. The dam, foundation, and jet piles were modeled with Plaxis 3D software. Due to sensitivity analysis, some of parameters are assumed according to the specifications of the materials in dam. The materials parameters used in modeling are shown in **Table 1**.

Table1. Material properties.

Parameters	Core	Zone 2b	Zone 2a	Zone 3	Sub Soil	Jet pile	wall	Mixture	Curtain	Drain	Bentonite
Hydraulic conductivity [m/day]	0.086	0.864	0.864	4.320	4.320	$0.864 \cdot 10^{-3}$		$0.864 \cdot 10^{-4}$	/	86.4	$0.864 \cdot 10^{-5}$
Unsaturated Unit weight [kN/m ³]	19	19	19	19	19	12.5		12.5	25	20	10.5
Saturated Unit weight [kN/m ³]	21	21	21	21	21	12.5		12.5	25	21	10.5
Young's modulus [kN/m ²]	20.10^3	70.10^3	70.10^3	70.10^3	70.10^3	25.10^3		500	40.10^6	100.10^3	400
Poisson's ratio [-]	0.3	0.2	0.2	0.2	0.2	0.25		0.4	0.1	0.15	0.4
Cohesion [kN/m ²]	21	1	1	1	1	200		18	/	1	16
Friction angle [°]	/	33	33	33	33	/		/	/	37	/

3.2 Mesh Generation and Boundary Conditions

In this modeling, 10-node tetrahedral elements for soil elements were used of the sufficient, and well-refined mesh generation of Plaxis 3D. With respect to boundary condition in Plaxis 3D, the top (Z max) boundaries set to free and the bottom (Z min) is set to fix, whereas the right (X max), left (X min), and boundaries: (Ymin,Y max) is set to normally fixed as well. In the ground water flow boundary set boundaries: (Ymin, Y max), and (Zmin) to closed. The remaining boundaries should be open.

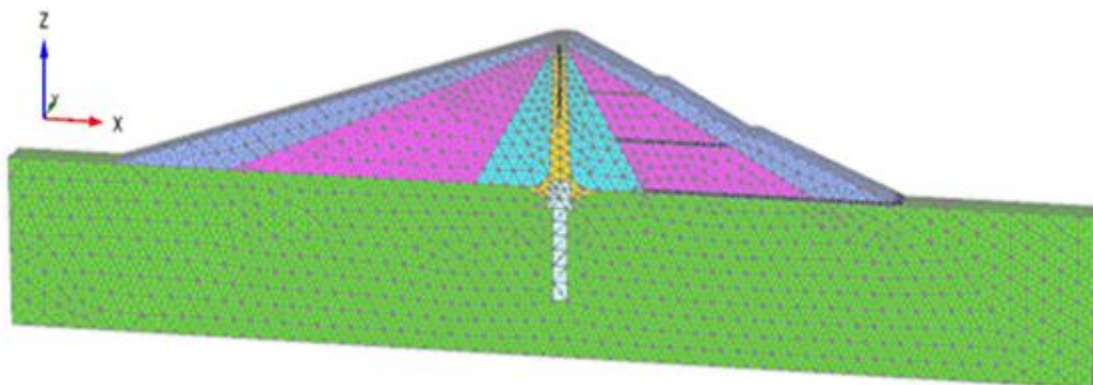

Figure 3. Generated mesh (diaphragm wall).

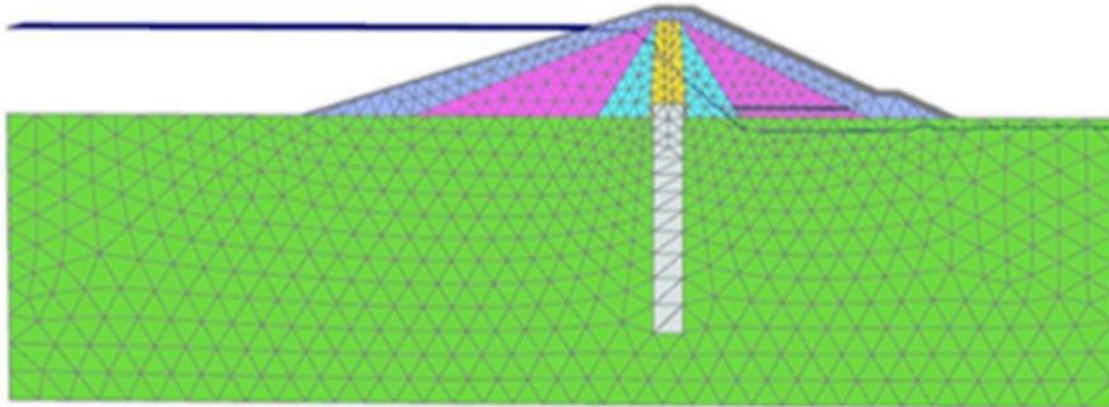

Figure 4. Generated mesh (jet pile).

3.3 Initial conditions

3.3.1 Initial Displacements

The hydrodynamic analyses of dams assume at time $t = 0$; the dam is in the state of static equilibrium, and the initial value of the displacements equal zero.

3.3.2 Initial Ground Water Surface

$$h_{p,0} = H_0 \quad (2)$$

Where $h_{p,0}$ is initial piezometric head in the domain (steady-state flow), and H_0 is specified piezometric head.

3.3.3 Initial Stresses

The initial stress The initial stresses are influenced by the weight of the material and the history of its formation. It is generated in Plaxis by means of the K'_0 (default) value defined automatically by the program.

$$\sigma'_v = \gamma \cdot d \quad (3)$$

$$\sigma'_h = \sigma'_v \cdot K'_0 \quad (4)$$

Where σ'_v is the vertical effective stress, σ'_h is the horizontal effective stress, and K'_0 is the coefficient for lateral earth pressure (**Brinkgreve, et al., 2018**).

3.4 Safety factor equation

SF is calculated by using the Phi-c reduction theory, where specific soil parameters are gradually reduced to failure. The parameters c and $\tan \phi$ are decreased gradually, and SF is calculated by **Eq. (5)**, where C and $\tan \phi$ are the real parameters, and they are decreased until a clear failure (**Brinkgreve, et al., 2014, and Dawson, et al., 1999**):

$$SF = \frac{\tan \phi}{\tan \phi_{red}} = \frac{C}{C_{red}} \quad (5)$$

4. RESULTS

4.1 Diaphragm wall

Fig. (5), and (6) depicts that the most critical surface in the initial state is deep with a large radius. Also, it is less deep with smaller radius in the last state. It is found to be near the upper part of the core and berm before reconstructions, so any remedial steps applied to lower the seepage at the clay will have essential improvement in FS. The value of SF increases in this analysis; it goes from 1.48, which is compared to the calculated value (1.498) (**Bednárová, et al., 2006**), to 1.56. When WL does not enter into the failure surface, the stability of slope increases. So, SF of dam can be increased by preventing the water from penetrating the slopes by means of drainage techniques. **Fig.7** shows the safety factor evaluations for studied situations (Initial state, Decrease WL, Increase WL, Last state) against the displacements. Although the displacements are not relevant, they indicate whether or not a failure mechanism has developed. The sudden drop in safety factor value is normal in c/ϕ reduction. During the incremental reduction of C and/or ϕ , an excessive displacement occurs and results in a lower safety factor than that in the previous increment or step. Plaxis will continue to adjust the incremental change in C and/or ϕ as if it is looking for the minimum safety factor (see **Fig. 7, 10**).

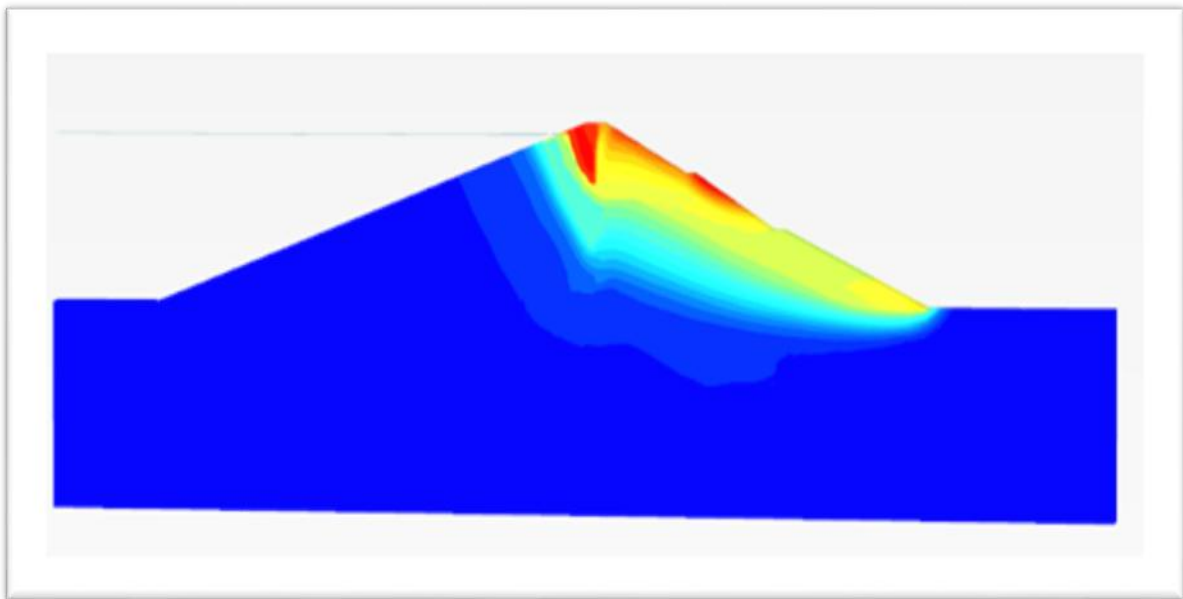

Figure 5. Slip surface at failure (Initial state), FS =1.48.

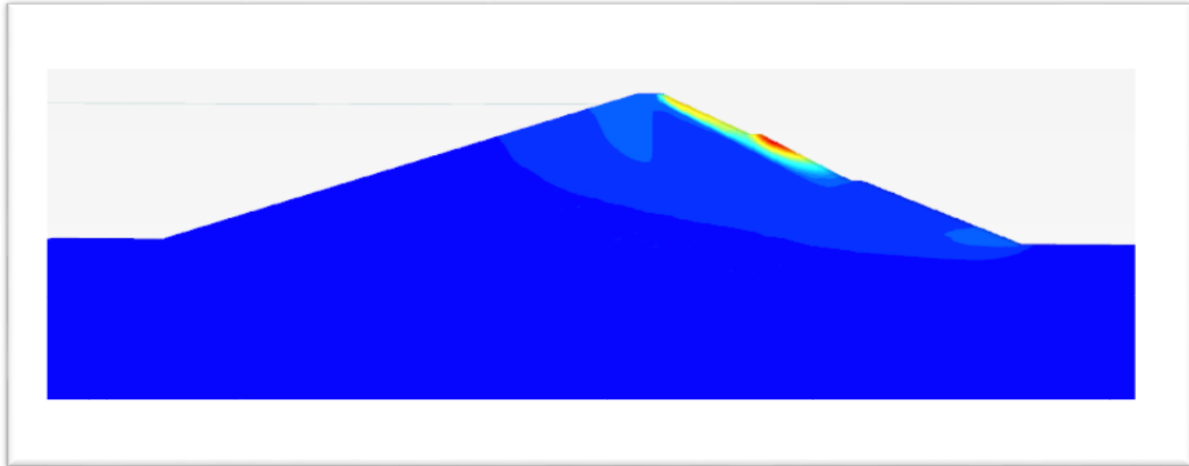

Figure 6. Slip surface at failure (Last state), FS = 1.56.

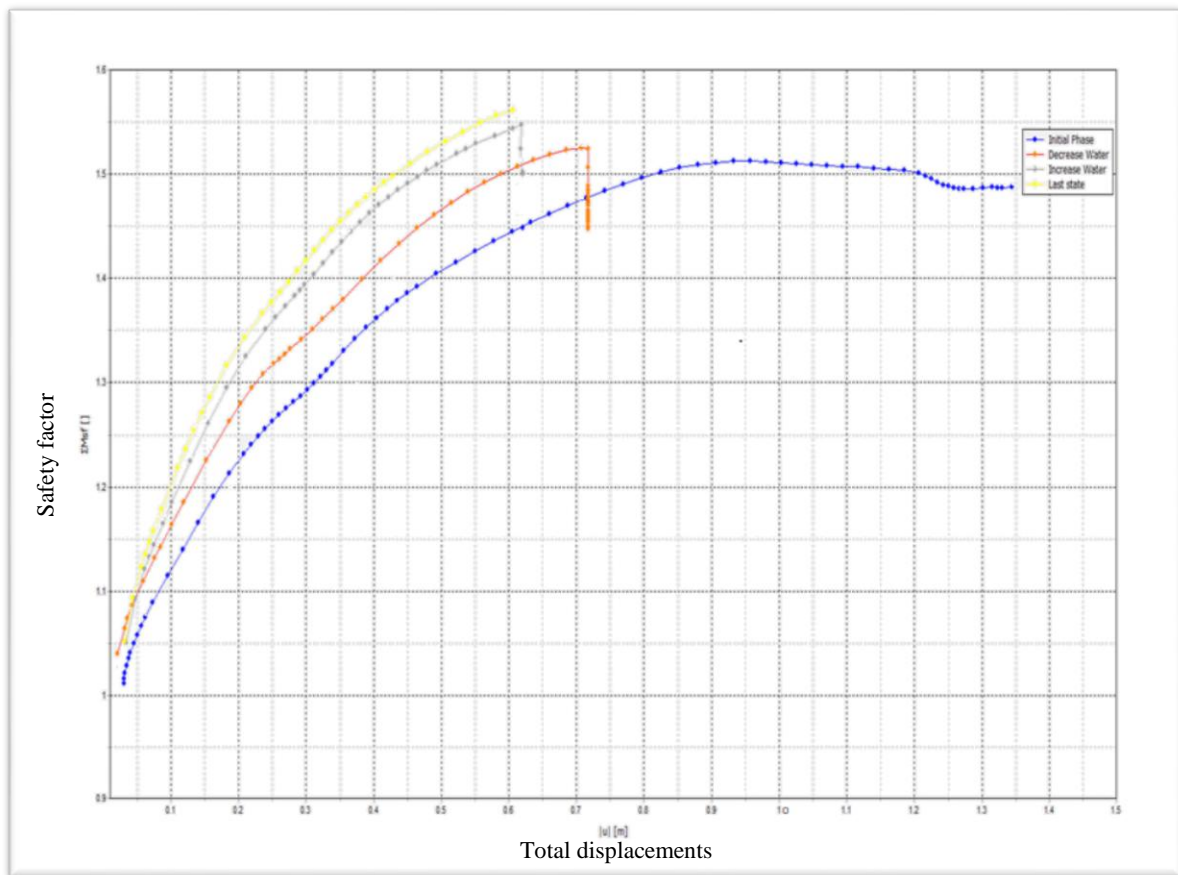

Figure 7. Evaluation of safety factor.

Initial state Decrease WL Increase WL Last state

4.2 Jet grouting

The failure surfaces generated from the analysis are given in **Fig. (8)**, and **(9)**. The failure is shallow, flatter with a small radius in both stages (initial state. last state), and the most critical surface in both stages is at the top of the dam, with the little difference in its shape that can be ignored. Stability results are expressed in **Fig. (10)** shows evaluation of safety factor for studied situations (Initial state, Decrease water level, Increase water level, Last state) vs. the displacements. The displacements don't have any physical meaning. SF even goes a little bit as up as 1.62 for the last state. Also, the (decrease- increase) of water level has a significant influence on safety factor value (Diaphragm wall, Jet grouting) because of the influence of pore water pressure variations with the time. It is very important to choose the appropriate period for decreasing and increasing water level in the reservoir.

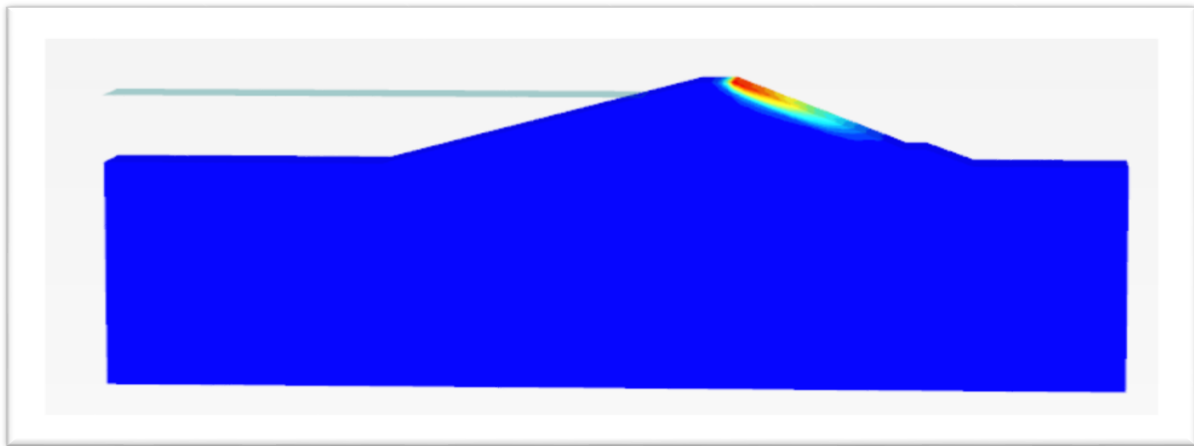

Figure 8. Slip surface at failure (Initial state), FS =1.60.

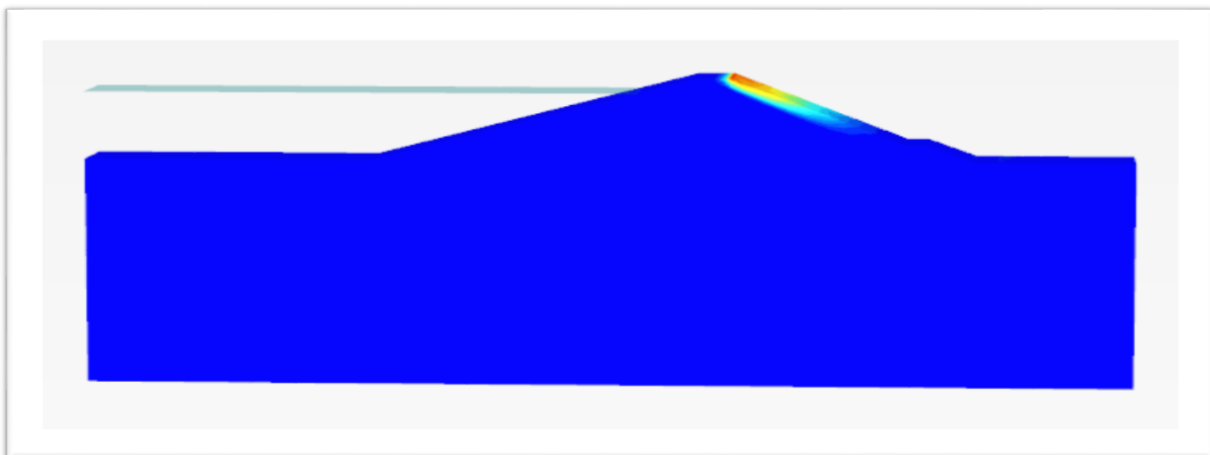

Figure 9. Slip surface at failure (Last state), FS =1.62.

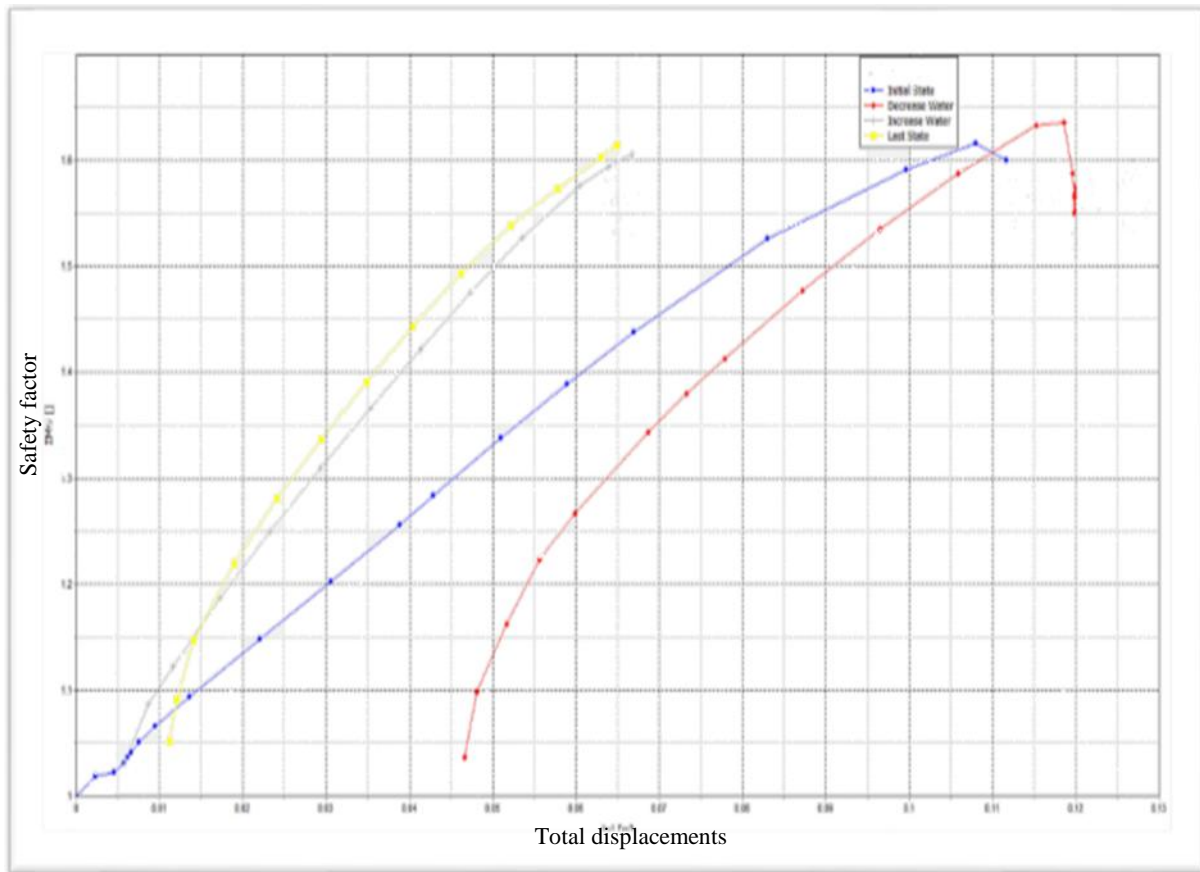

Figure 10. Evaluation of safety factor.

—◆— Initial state —■— Decrease WL —▲— Increase WL —●— Last stat

4. CONCLUSIONS

The main findings of this study can be summarized as follows:

1. The value of safety factor before reconstruction stages is (1.48), which is compared to the calculated value depended on: 1- the shape of failure surface, 2- the data taken from measuring well, 3- Bishop method, equals (1.498).
2. The results of the safety factor consider the cross-section positions in two cases: 1- in the middle (diaphragm wall case), 2- at the end of dam (jet grouting case). The results show that the value of safety factor in the middle of dam -where the highest height- equals (1.48) because of the high value for the hydraulic gradient. On the other hand, the highest value of the safety factor at the end of dam -where the lowest height-equals (1.6). As a result, the height of dam has a definite impact on the shape and location of the failure surface and the value of safety factor.



3. The most critical surface in both cases (initial state, last state) is near the upper part of the core and berm, so any remedial step is applied to lower the seepage at the clay will have essential improvement in SF.
4. It is noted that the variation of water level (decrease- increase) affects safety factors because of water movement in the soil pores, thus reducing the effective stress, soil strength, and stability.
5. The stability analysis is performed using a 3D analysis taking into consideration the influence of pore water pressure variations with the time.

REFERENCES

- Abramson, L., Lee, T., Sharma, S., and Boyce, G., (2002), "Slope Stability and Stabilization Methods". John Wiley, New York, ISBN: 978-0-471-38493-9. P 712
- Fattah, M. Y., Zbar, S. B., and Al-Kalali, M. H., (2016), " Three-Dimensional Finite Element Simulation of the Buried Pipe Problem in Geogrid Reinforced Soil". Journal of Engineering, Volume 22, Issue 5, pp. 60 -73
- Bredy, S., and Jandora, J., (2019), "Three-Dimensions Modelling of a Jet Pile Construction in the Karolinka Dam", Acta Journal (2019), Volume 67, Issue 3, pp. 621-636.
- Pařílková, J., Zachová, Z., and Pařílek, L., (2016), "The earth-fill dam of the Karolinka water reservoir monitored by the EIS method", 4th Conference and Working Session. Brno University of Technology, ISBN: 978-80-214-5338- 8. ISSN: 2464-4595, pp. 185–209.
- Hodak, J., (2014), "Karolinka Dam-Dam safety supervision during diaphragm wall construction". International Conference. Slovakia. ISBN: 978-80-971596. pp.100–122.
- Aljorany, N. A, Ibrahim, F. S., and Al-Adly, I. A., (2014), " Heave Behavior of Granular Pile Anchor-Foundation System (GPA-Foundation System) in Expansive Soil ". Journal of Engineering. Volum 20, Issue 4, pp. 1–22.
- Labuz, J. F., and Zang, A., (2012), "Mohr-Coulomb Failure Criterion". Rock Mechanics and Rock Engineering Journal. Volum 45, Issue 6, pp. 975–979. Journal homepage: <https://link.springer.com/journal/603>.
- Brinkgreve, R. B, J., Engin, E., and Swolfs, W, M., (2018), "PLAXIS 3D Anniversary edition". [online] <https://www.plaxis.com/support/manuals>.
- Brinkgreve, R. B, J., Engin, E., and Swolfs, W, M., (2014) "PLAXIS 2D Anniversary edition, full manual". [online] <http://www.plaxis.nl>.
- Dawson, E. M., Roth, W. H and Drewcher, A., (1999), "Slope stability analysis by strength reduction". Geotechnique Journal. Volum 49, Issue 6, pp. 835–403.
- Bednářová, E., and Grambličková, D., (2006), " Karolinka Dam – Diaphragm wall". Permit Documents of Hydro-Consulting company. Slovakia.